

**GEOLOGY AND OCCURRENCE OF GROUND WATER  
NEAR BOWBELLS.  
BURKE AND WARD COUNTIES, NORTH DAKOTA**

By  
H. M. Jensen  
Geological Survey  
United States Department of the Interior

**NORTH DAKOTA GROUND WATER STUDIES  
NO.42**

Prepared by the United States Geological Survey in cooperation with  
the North Dakota State Water Conservation Commission, and the  
North Dakota Geological Survey

PUBLISHED BY  
NORTH DAKOTA STATE WATER CONSERVATION COMMISSION  
1301 STATE CAPITOL, BISMARCK, NORTH DAKOTA

-1962-

**HYDROLOGIC CYCLE**

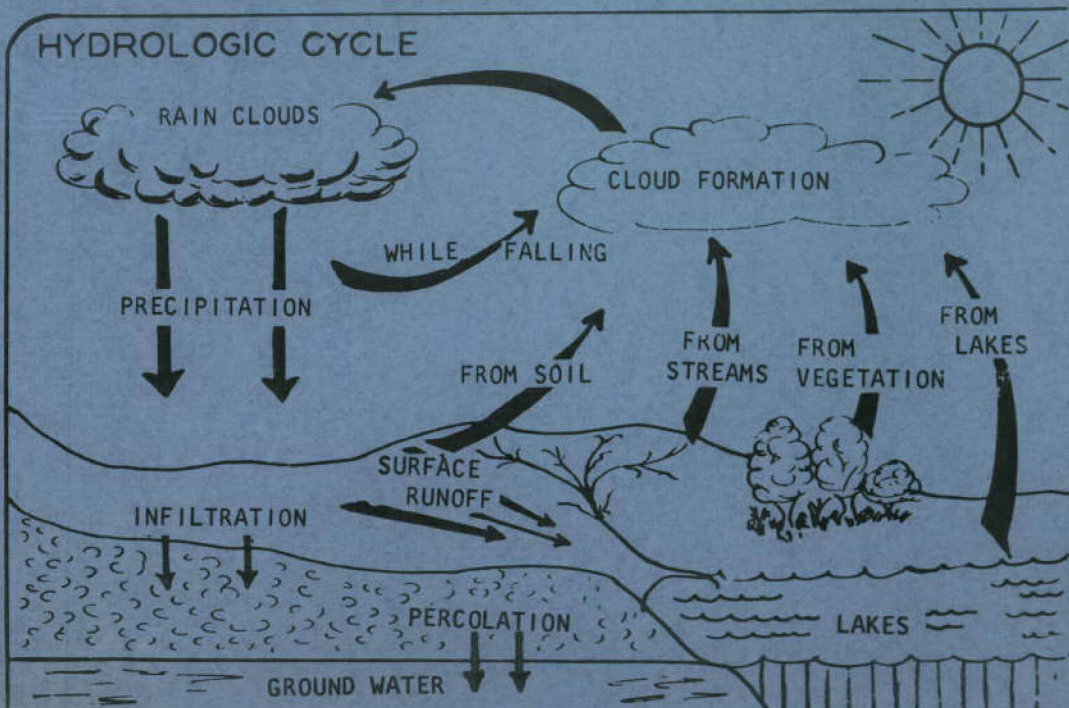



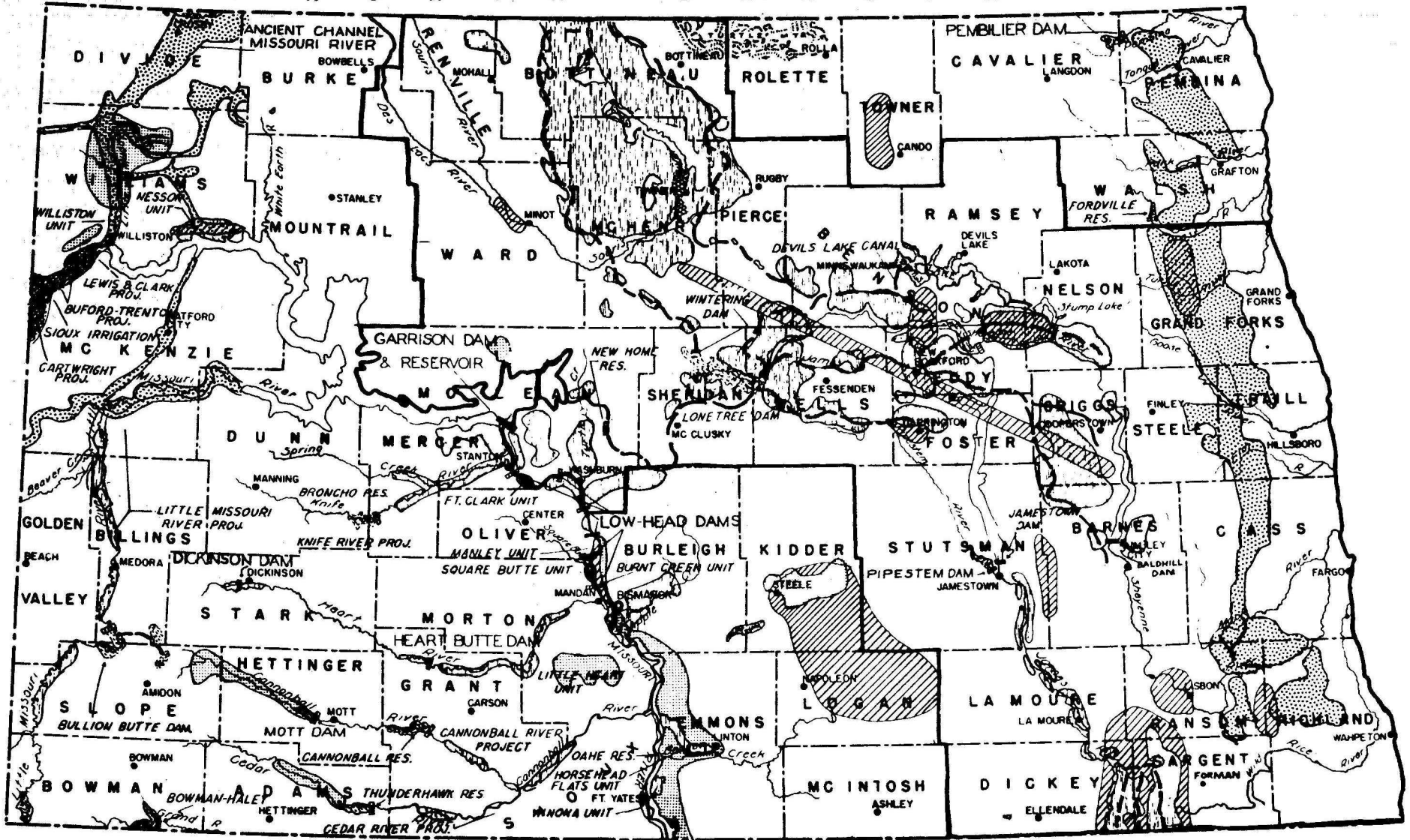

N O R T H D A K O T A



NORTH DAKOTA STATE WATER CONSERVATION COMMISSION

# WATER RESOURCES DEVELOPMENT PLAN



-  LANDS UNDER IRRIGATION
-  AREAS CONSIDERED IRRIGABLE
-  AREAS BEING INVESTIGATED
-  PROPOSED FOR INVESTIGATION



DAM & RESERVOIR SITES



PROPOSED CANALS

-  GARRISON DIVERSION CONSERVANCY DISTRICT BOUNDARY
-  GROUNDWATER AQUIFERS

Gov. William L. Guy  
 CHAIRMAN  
 OSCAR LUNSETH  
 VICE CHAIRMAN  
 MILO W. HOISVEEN  
 SECRETARY AND STATE ENGINEER  
 RICHARD P. GALLAGHER  
 MATH DAHL  
 WILLIAM W. CORWIN  
 EINAR H. DAHL  
 HENRY J. STEINBERGER

GEOLOGY AND OCCURRENCE OF GROUND WATER NEAR BOWBELLS,  
BURKE AND WARD COUNTIES, NORTH DAKOTA

By  
H. M. Jensen  
Geological Survey  
United States Department of the Interior

North Dakota Ground-Water Studies No. 42

Prepared by the United States Geological Survey in cooperation with  
the North Dakota State Water Conservation Commission, and the  
North Dakota Geological Survey

Published By

North Dakota State Water Conservation Commission  
1301 State Capitol, Bismarck, North Dakota

## CONTENTS

	<u>Page</u>
Abstract-----	1
Introduction-----	3
Location and general features of the area-----	3
Purpose and scope of the investigation-----	4
Previous investigations-----	5
Physiographic features-----	6
Well-numbering system-----	7
Geology and occurrence of ground water-----	8
Geologic history-----	8
Geologic formations and their water-bearing properties----	10
Bedrock-----	12
Older rocks-----	12
Fort Union Formation-----	13
Glacial drift-----	14
Till and associated sand and gravel deposits----	15
Glaciofluvial deposits-----	17
Alluvium of Recent age-----	19
Recharge, movement, and discharge of ground water-----	20
Quality of water-----	21
Summary of ground-water conditions-----	24
References-----	65

## ILLUSTRATIONS

	<u>Facing page</u>
Figure 1. Map showing physiographic provinces in North Dakota and location of the Bowbells area-----	3
2. System of numbering wells and test holes-----	6
3. Map of Bowbells area showing locations of wells and test holes-----	10
4. Geologic map of the Bowbells area-----	14
5. Geologic sections in the Bowbells area-----	16

## TABLES

	<u>Page</u>
1. Cretaceous, Tertiary, and Quaternary stratigraphy in the Bowbells area-----	11
2. Chemical analyses of ground water-----	27
3. Records of wells and test holes-----	28
4. Logs of test holes-----	39

GEOLOGY AND OCCURRENCE OF GROUND WATER NEAR BOWBELLS,  
BURKE AND WARD COUNTIES, NORTH DAKOTA

By  
H. M. Jensen

ABSTRACT

The Bowbells area, comprising about 212 square miles, is in northwestern North Dakota. The land surface is a gently rolling upland plain, which is broken by the relatively deep valley of the south-flowing Des Lacs River and its shallow tributary drainage system.

The area is underlain by rocks of Paleozoic, Mesozoic, and Cenozoic ages. The Tongue River Member of the Fort Union Formation of Paleocene age is the youngest bedrock. It is overlain by unconsolidated deposits of glacial drift and alluvium of Recent age.

Ground water in the Bowbells area is obtained from aquifers in the Tongue River Member and glacial drift. Bedrock aquifers are found in beds of sandy clay, sand, and (or) lignite. The aquifers yield water to wells that supply municipal and private water-supply systems.

The glacial drift is subdivided into two general types: (1) glacial till and associated sand and gravel deposits and (2) glacio-fluvial deposits. Glacial till is relatively impermeable; however, lenticular and discontinuous sand and gravel deposits interbedded in the till or at the base of the glacial drift are generally aquifers or sources of water.

Glaciofluvial deposits are contained in terraces, diversion channels, kames and eskers, and outwash channels. The deposits, consisting of silt, sand, and (or) gravel, in the terrace, diversion channel, and kame and esker units are thin and small in areal extent and are not reliable sources of ground water. Sand and gravel deposits in outwash channels yield small quantities of water to wells. The drift aquifers generally supply enough water for domestic and farm use.

Alluvium of Recent age, consisting of deposits of silt, clay and fine sand, is found in the valley of the Des Lacs River and at the mouths of its larger tributaries, but it yields little or no water to wells. Ground water in the Bowbells area is derived from percolation of rain or melting snow. The regional movement of ground water in the bedrock seems to be northeastward, but it probably differs locally.

Water of a quality adequate to meet U.S. Public Health Standards is difficult to obtain in the Bowbells area. Aquifers in the Tongue River Member of the Fort Union Formation and in glacial till and associated sand and gravel deposits contain water that is moderately to highly mineralized. Shallow wells in saturated glaciofluvial deposits yield less highly mineralized water.

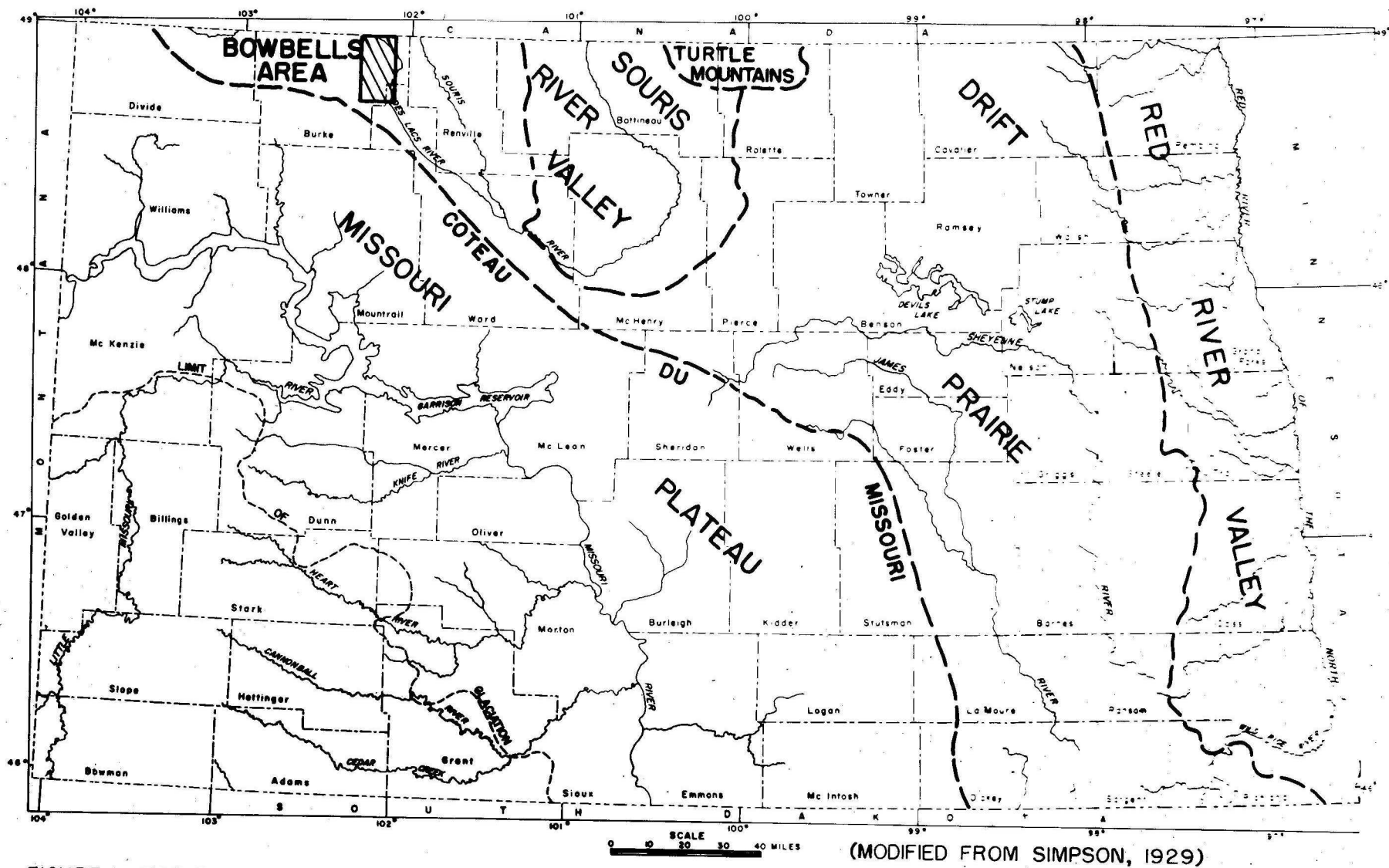

FIGURE 1--MAP SHOWING PHYSIOGRAPHIC PROVINCES IN NORTH DAKOTA AND LOCATION OF THE BOWBELLS AREA



## INTRODUCTION

### Location and General Features of the Area

The Bowbells area comprises about 212 square miles of Burke and Ward Counties in northwestern North Dakota (fig. 1). The area includes all of Tps. 161, 162, and 163 N., R. 89 W., and parts of Tps. 161, 162, and 163 N., Rs. 88 and 90 W., and T. 164 N., Rs. 88, 89, and 90 W.

Bowbells, the only city in the area, had a population of 680 in 1960. The unincorporated communities of Northgate and Coteau are also in the report area. The highway transportation network consists of U.S. Highway 52 and State Highways 8 and 5, which intersect at Bowbells. The Great Northern Railroad and the Minneapolis, St. Paul and Sault Ste. Marie Railroad serve the area. The principal occupation is farming; the main crop is wheat.

The average annual precipitation recorded by the U.S. Weather Bureau at Bowbells was 15.38 inches from 1925 to 1959. The average annual temperature during the same period was 38.1°F.

## Purpose and Scope of the Investigation

The United States Geological Survey, the North Dakota State Water Conservation Commission, and the North Dakota Geological Survey cooperate in investigating the ground-water resources of North Dakota. Many of these investigations begin in the vicinity of communities requesting help in locating new or additional water supplies. The investigation of the Bowbells area was made as a part of the cooperative ground-water program in North Dakota to help the city of Bowbells in evaluating ground-water sources near the city.

This report describes a reconnaissance of ground-water conditions in the vicinity of Bowbells, N. Dak., and includes compilation and interpretation of data derived from test drilling, from an inventory of existing wells, from chemical analyses of water samples, and from published reports and open-file records.

### Previous Investigations

The geology and occurrence of ground water in a large part of northwestern North Dakota were mapped and described as a part of the program of the Department of the Interior for the development of the Missouri River basin, (Lenke, 1960, and LaRocque, Swenson, and Greenman, 1951). The surficial geology of part of the mapped area in the vicinity of Bowbells has been reproduced with slight modification and is shown as figure 4 in this report. A study of the available ground-water resources for the city of Bowbells was made by Simpson (1927); data from this study are included in a general report of the geology and ground-water resources of the State (Simpson, 1929). A statewide investigation of municipal water supplies was made by Abbott and Voedisch, (1938).

### Physiographic Features

The Bowbells area is in the northwestern part of the Drift Prairie physiographic region defined by Simpson (1929, p. 5). (See fig. 1.) The land surface is a gently rolling upland plain. It slopes from an altitude of about 2,020 feet in the southwest corner to about 1,840 feet in the northeast corner. The topography of the plain is typical of ground moraine in the region and is characterized by small mounds, shallow depressions, and marshy areas.

The south-flowing Des Lacs River cuts a relatively deep valley through the eastern part of the report area and is joined by several shallow tributary channels. At the Canadian border, the Des Lacs River valley is entrenched about 60 feet below the upland plain and has a width of about 1,200 feet. Its depth and width increase to about 170 feet and 3,700 feet, respectively, at the southern edge of the Bowbells area. Much of the valley floor is covered by a shallow lake. The water level in the lake, which is named Upper Des Lacs Lake, is maintained by low artificial dikes south of the area of investigation. Stony Creek and Stony Run are the main tributary channels of the Des Lacs River and flow eastward through the southern and northern parts of the report area respectively. In other parts of the area smaller drainage-ways terminate in shallow depressions and marshy areas.

Most of the area is treeless, although a few grow along the banks of the Des Lacs River and along the lower slopes of some of its tributaries.

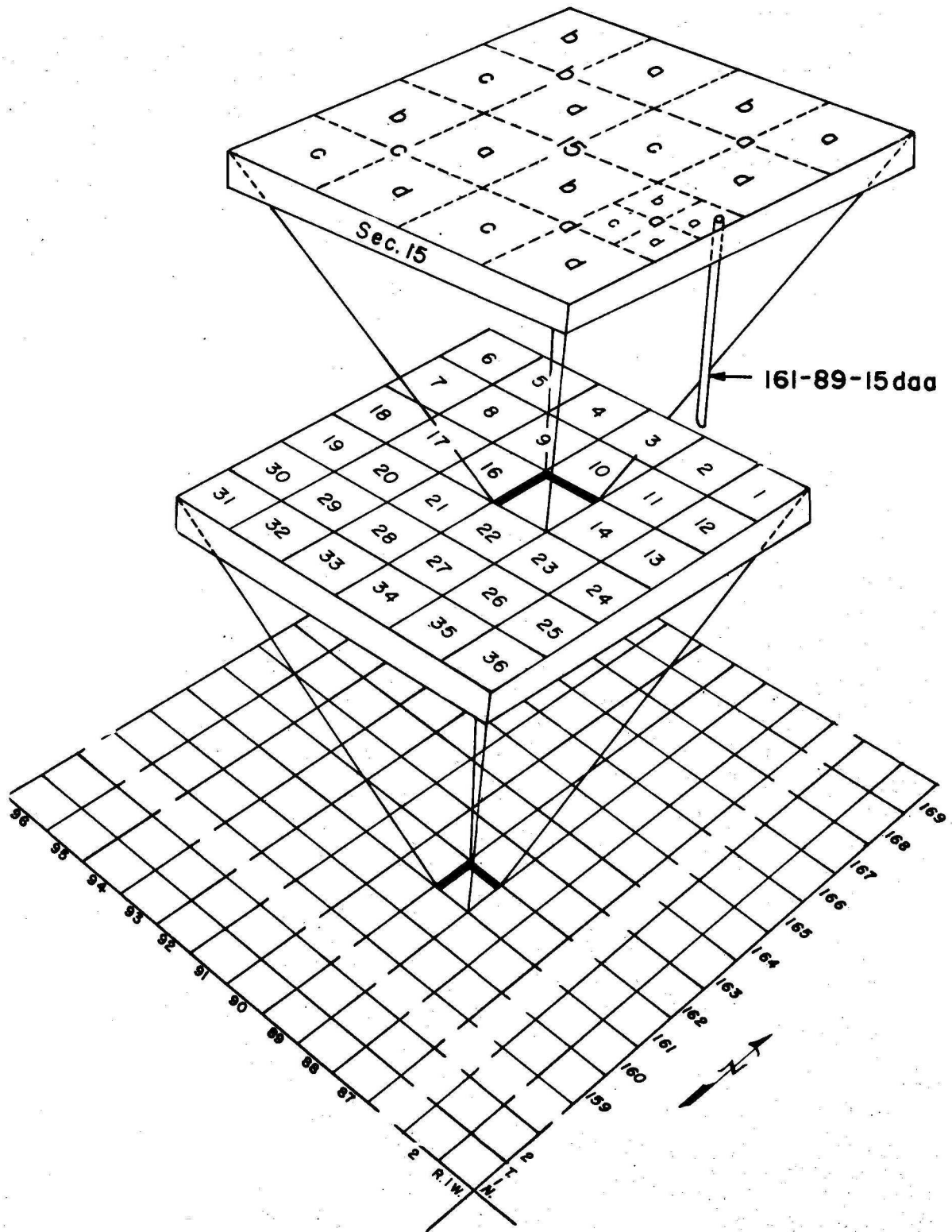

FIGURE 2--SYSTEM OF NUMBERING WELLS AND TEST HOLES

### Well-Numbering System

All wells and test holes referred to in this report have been assigned numbers indicating their location within the land subdivisions surveyed by the U.S. Bureau of Land Management. The first numeral within the number indicates the township, the second the range, and the third the section in which the well or test hole is located. The lower case letters (a, b, c, d) following the section number designate the quarter section, quarter-quarter section, and quarter-quarter-quarter section (10-acre tract). If more than one well is located in a 10-acre tract, consecutive numerals are added after the lower case letters. The well-numbering system is illustrated in figure 2.

## GEOLOGY AND OCCURRENCE OF GROUND WATER

### Geologic History

Rocks older than Tertiary age were not identified in test-hole samples; however, deep-well records (Towse, 1952, Lemke, 1960, p. 11-19) show that early Paleozoic and late Mesozoic formations composed of marine limestone, dolomite, sandstone, and shale were deposited in the area.

During the Paleocene Epoch of the Tertiary Period a widespread formation, the Fort Union Formation, was deposited in shallow lakes and on river flood plains. During a long period of erosion prior to the Pleistocene Epoch, the soft rocks of the Fort Union Formation were dissected, leaving local relief considerably greater than that of the present surface.

Several ice sheets, possibly as many as four, advanced and retreated across the Bowbells region during Pleistocene time. Only drift of the last ice sheet is known to be exposed in the report area; if older drifts occur, no positive evidence of them has been found. The last ice sheet to cover the Bowbells area in late Wisconsin time advanced southwestward across the area at least as far as the Coteau du Missouri (fig. 1). Debris deposited by this ice advance filled the deep valleys that had been carved prior to the last glaciation.

As the last ice sheet melted and disappeared from the area, melt water flowed from the stagnating ice blocks along numerous outwash channels (fig. 4). It seems that most of the Des Lacs River valley south of the report area existed prior to the last glaciation, whereas the present valley in the area was largely scoured by melt water from the last ice sheet. The former river channel in the Bowbells area is probably buried beneath a thick mantle of till.

One of the last significant events in the history of the area was the occurrence of landslides on the west side of the Des Lacs River valley. The landslides are small and scattered in the report area; but they are larger and more numerous south of the area. They may have been caused by the movement of ground water north-eastward from the Coteau du Missouri along the contact of the ground moraine and the underlying Fort Union Formation until intercepted by the river valley.



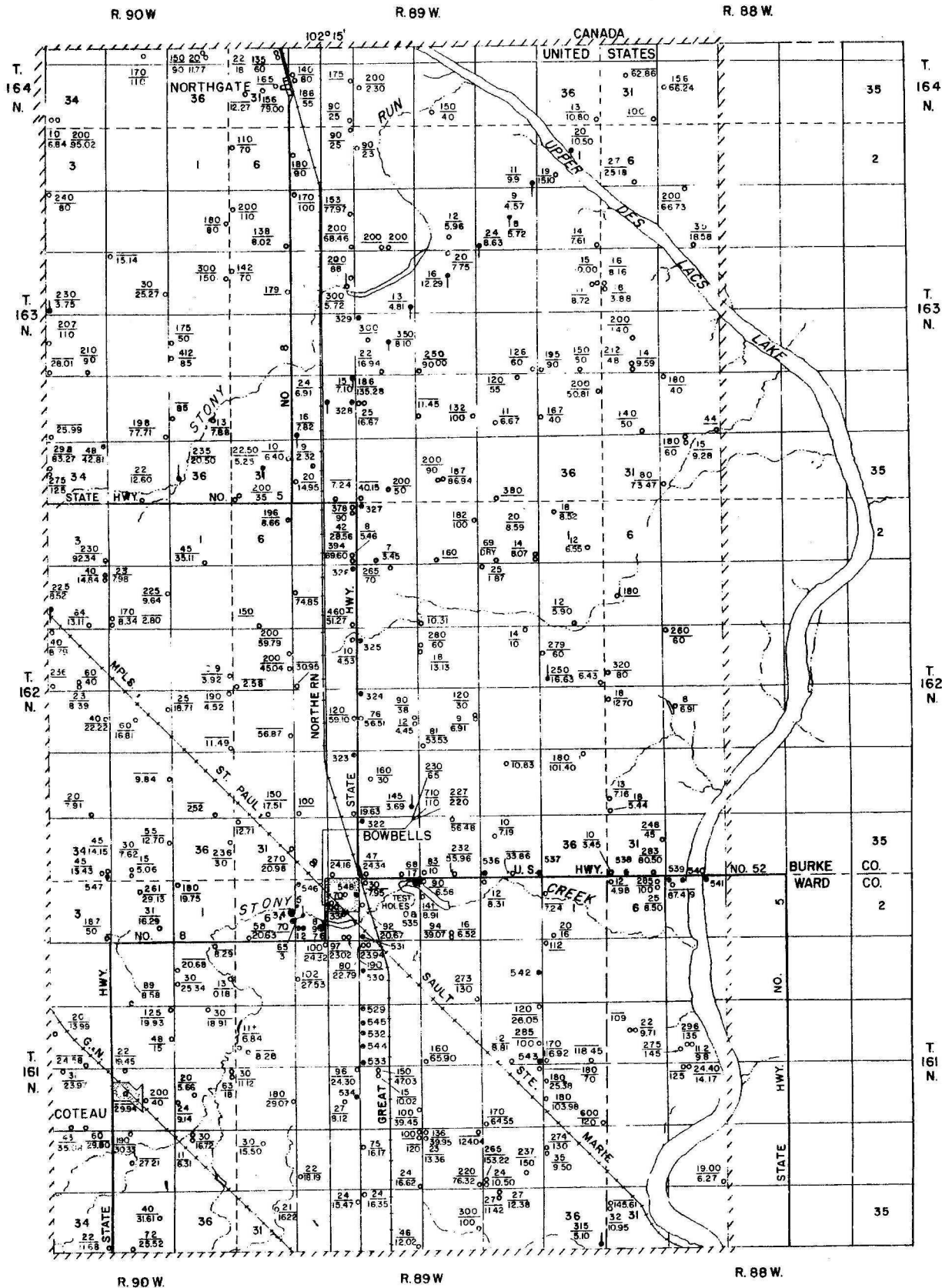

**EXPLANATION**

• 274 / 130 DOMESTIC OR FARM WELL; UPPER NUMBER INDICATES DEPTH OF WELL, LOWER NUMBER INDICATES DEPTH TO WATER.  
 • 538 TEST HOLE DRILLED IN CONNECTION WITH NORTH DAKOTA GROUND WATER STUDY NUMBER 42.  
 • 99 / 78 LOCATION OF MORE THAN ONE TEST HOLE.

0 1/2 1 2 3 4 MILES  
 SCALE

↓ TEST HOLE DRILLED IN CONNECTION WITH MISSOURI RIVER BASIN PROGRAM.  
 • BUREAU OF RECLAMATION TEST WELLS  
 ▭ REPORT AREA

**FIGURE 3 -- MAP OF THE BOWBELLS AREA SHOWING LOCATIONS OF WELLS AND TEST HOLES.**

## Geologic Formations and Their Water-Bearing Properties

Information regarding the stratigraphy of the Bowbells area was obtained by geologic reconnaissance, inventory of wells, test drilling, and a review of published reports. Test drilling was completed with a hydraulic-rotary drilling machine owned by the North Dakota State Water Conservation Commission. The locations of the wells and test holes are shown on figure 3, and the test-hole logs are shown in table 4. The depths of the test holes ranged from 12 to 600 feet and averaged 145 feet. Drilling samples of the formations penetrated were taken at 5-foot intervals, and sample logs were prepared by visual inspection of the cuttings. The distribution of the surficial geologic units and the location of geologic sections are shown on figure 4, and geologic sections based upon logs of selected test holes are shown in figure 5. Information concerning the deeper formations in the area was obtained from logs of oil-test holes supplied by the North Dakota Geological Survey. Also the logs of other wells and test holes were studied. The following stratigraphic section is based on the examination of samples from the test holes drilled and the interpretation and extrapolation of published logs and reports.

Table 1.--Cretaceous, Tertiary, and Quaternary stratigraphy in the  
Bowbells area

Cenozoic Era

Quaternary System

Recent Series

Alluvium

Pleistocene Series

Wisconsin Glaciation

Glaciofluvial deposits

Till and associated sand and gravel deposits

Pre-Wisconsin(?) Glaciation

Tertiary System

Paleocene Series

Fort Union Formation

Tongue River Member

Cannonball Member

Mesozoic Era

Cretaceous System

Upper Cretaceous Series

Hell Creek Formation

Fox Hills(?) Sandstone

Pierre Shale

Niobrara Formation

Carlisle Shale

Greenhorn Limestone

Graneros Shale

Lower Cretaceous Series

Dakota Sandstone

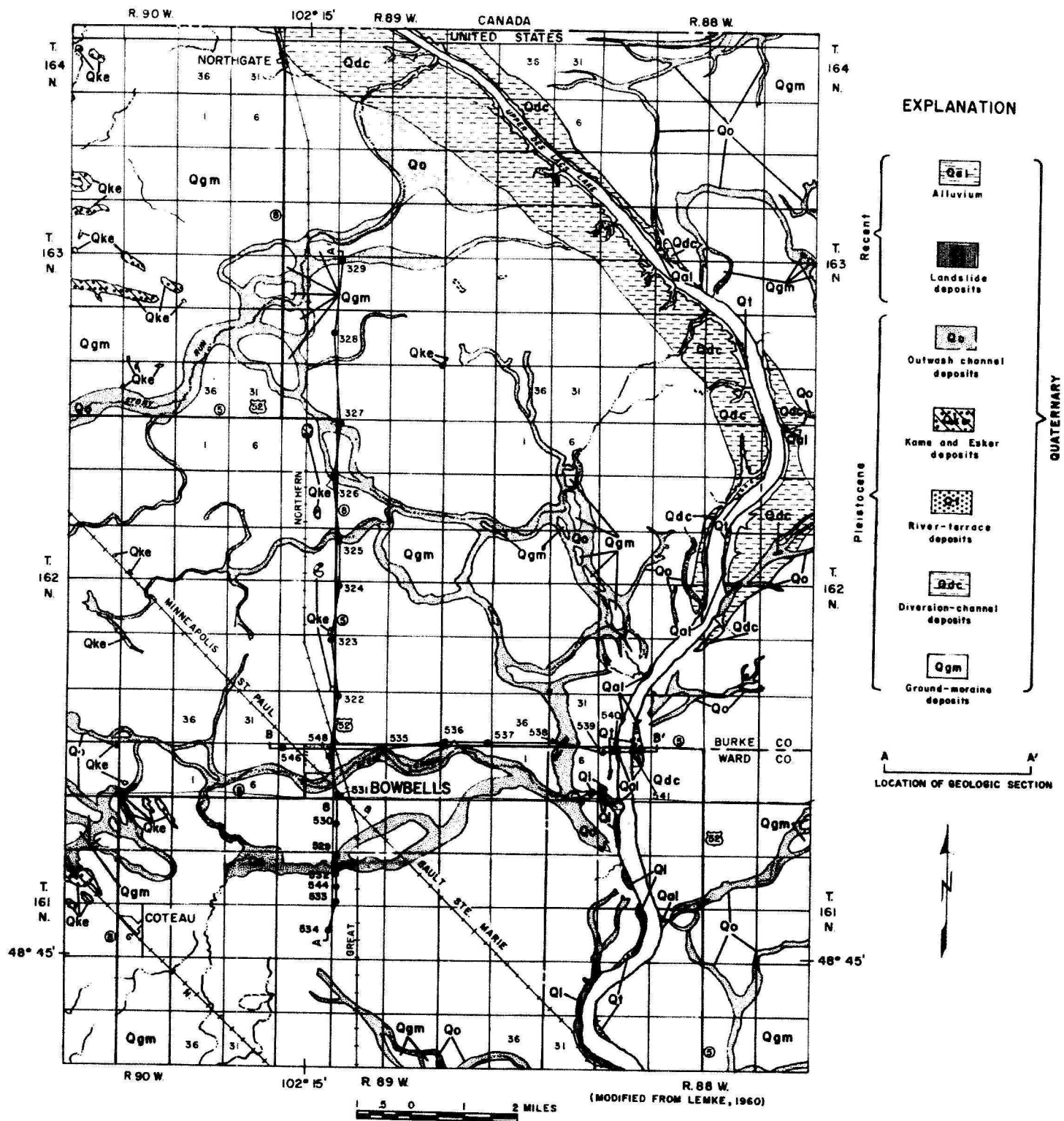

**FIGURE 4--GEOLOGIC MAP OF THE BOWBELLS AREA**

## Bedrock

Older rocks.--A thick sequence of older sedimentary rocks of Paleozoic and Mesozoic age underlie the Cretaceous rocks in the Bowbells area. Although some of these rocks probably are water bearing, they are not presently considered to be of importance because of their great depth and the probable poor quality of the water contained in them.

Rock formations of the Cretaceous System overlie the older Mesozoic rocks (table 1). Lemke (1960, p. 11-29) ascribes a total of 3,060 feet to the Cretaceous System in the Souris River area. Most of these rocks consist of shale and are unimportant as aquifers, but the Dakota Sandstone, Fox Hills Sandstone, and Hell Creek Formation probably are water bearing. Because all these rocks are 1,000 or more feet below the land surface, drilling to them is relatively expensive. Although these aquifers are not used as sources of ground water in the Bowbells area, they are utilized in other areas of North Dakota.

Fort Union Formation.--The youngest bedrock throughout the Bowbells area is the Fort Union Formation of Paleocene age. The Fort Union does not crop out in the area but was penetrated in most of the test holes. The greatest penetration was 520 feet in test hole 548 (161-89-5aad). The Fort Union has been subdivided into several members in some other areas of the Great Plains, where the formation is well exposed. However, these units cannot be distinguished readily on the basis of drill cuttings. The test-drilling data indicate that the Fort Union consists mainly of alternating and discontinuous beds of light- to dark-gray clay and sandy clay, beds of light-gray uniform fine sand, and lignite.

The beds described above probably represent the Tongue River Member as described from other areas. Numerous imbedded ironstone concretions are found in the clays and sands. Some beds are weakly cemented with calcium carbonate and show stratification. Beds or horizons are apparently discontinuous through the report area, as no specific marker beds were identified.

The stratigraphically lower Cannonball Member of the Fort Union Formation was not identified from drill cuttings. The member crops out in the vicinity of Sawyer, about 80 miles southeast of Bowbells (Brown and Lemke, 1948). It consists of alternating beds of gray to tan silt, sand, and sandy shale. The member supplies water to wells in central and south-central North Dakota, but it is not known to yield water to wells in the report area.

The Tongue River Member of the Fort Union Formation is the source of water for most wells in the area. The aquifers consist of sand, sandy clay, and (or) lignite. Drilled wells, ranging in depth from about 50 feet to more than 500 feet, yield water that supplies the municipal water system of Bowbells, private residences in the small communities of Northgate and Coteau, and numerous farmsteads (table 3).

Water for drinking and cooking is hauled to many farms because the high mineralization and in some places, the color limit the use of water from the Tongue River Member.

#### Glacial drift

The glacial drift is divided into two general types in this report; (1) glacial till and associated sand and gravel deposits and (2) glaciofluvial deposits. Thirty-six test holes penetrated the entire thickness of glacial drift. Although examination of the drill cuttings from test holes did not reveal an oxidized zone that might indicate an older drift, the relatively few test holes drilled through the drift are probably inadequate to definitely establish the sequence of glacial deposition.

Till and associated sand and gravel deposits.--Glacial till

and associated deposits of sand and gravel underlie the areas of ground moraine (fig. 4) and are exposed throughout the report area, except where locally covered by glaciofluvial or recent alluvial deposits. The till is predominantly silt and clay, but contains rock fragments ranging in size from sand to large boulders. The rock fragments are composed principally of limestone and dolomite and lesser amounts of igneous and metamorphic rocks. The upper part of the till has been oxidized to grayish-yellow or yellow-brown; the lower part of the till is not oxidized and is bluish gray. The till was deposited directly from the melting ice and was subjected to little or no subsequent sorting by wind or water.

Isolated lenses and discontinuous deposits of sand and gravel are associated with the till. The lenticular sand and gravel deposits interbedded in the till -- completely enclosed by till -- are of small areal extent. Discontinuous sand and gravel deposits, common at the base of glacial drift, probably have a larger areal extent. Both the lenticular and the discontinuous sand and gravel bodies were deposited by local melt water of glacial streams.



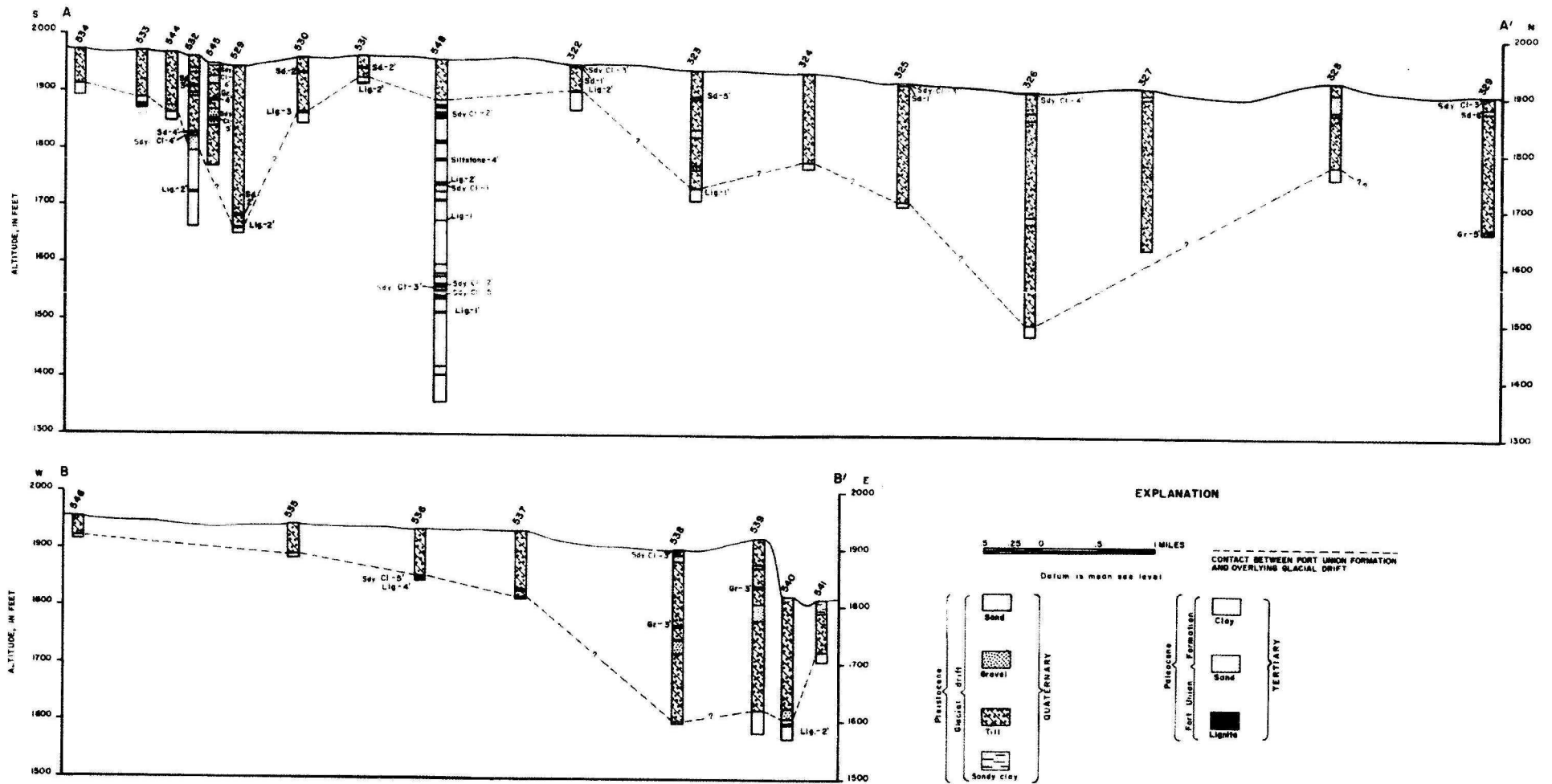

FIGURE 5--GEOLOGIC SECTIONS IN THE BOWBELLS AREA

The thickness of the till and associated sand and gravel deposits, as determined by test drilling, ranges from 5 feet in test hole 8 (161-89-5cad1) to 410 feet in test hole 326 (162-89-8aaa) and averages 106 feet. However, it is difficult to pick the top of the bedrock formation because hydraulic rotary drilling tends to concentrate the coarse-grained till constituents even after the drill may have penetrated the bedrock; the thickness of the deposits in some places may be less than that shown on figure 5 and in table 4. Generally, except for thick deposits in buried channels or valleys, the till is probably less than 150 feet thick west of the Des Lacs River. At Bowbells it is less than 50 feet thick.

The permeability of the till differs from place to place in the proportion of sand and gravel it contains. Because the till is composed of unsorted materials, and because the spaces between the larger particles tend to be filled with finer materials, it does not ordinarily yield water readily to wells.

The most productive aquifers in the till are the lenticular sand and gravel deposits interbedded in the till and a discontinuous series of sand and gravel deposits at the base of the glacial drift. Wells that yield sufficient water for farm and domestic purposes can be developed in the lenticular deposits; however, the yields of wells penetrating these aquifers, which are completely surrounded by dense till, decrease rapidly as the aquifers become unwatered. The discontinuous series of sand and gravel deposits at the base of the glacial drift generally are capable of producing higher yields than the lenticular deposits; however, recharge through the glacial till is slow, and pumping rates must be regulated if well yields are to be constant.

Generally the water from aquifers in the till and associated sand and gravel deposits is relatively hard and contains more than 1,500 parts per million (ppm) of dissolved mineral constituents.

Glaciofluvial deposits.--Deposits ranging in grain-size from clay to gravel comprise the surficial geologic units shown in figure 4 as river terraces, diversion channels, kames and eskers, and outwash channels. The materials were deposited by streams from the melting glacier and are called glaciofluvial deposits. The glaciofluvial deposits in terrace, diversion channel, and kame and esker units generally are thin and (or) of small areal extent. Consequently, they contain little or no ground water and are not important aquifers.

The outwash channels form an interconnected drainage pattern whose trend is eastward across the ground-moraine plain to the present valley of the Des Lacs River. The channels are commonly 500 to 1,500 feet wide and 5 to 30 feet deep; they have flat or gently rounded floors and backslopes that are gentle to moderately steep. The drainage through these channels is by small intermittent and discontinuous streams; some channels contain only ponds and marshes. East of the Des Lacs River the outwash channels are shallower. Lemke (1960, p. 85) describes the deposits as follows: "the channel deposits range in thickness from an indistinct veneer which has now become part of the soil profile to 20 feet. In general, deposits more than 5 feet thick consist of sand and gravel, whereas the thinner deposits consist of silt and clay." The variations of grain size in the deposits is rapid both vertically and horizontally. The coarser materials are found in the thicker sections near the middle of the deposits, whereas finer materials are found near the sides of the channels. The outwash-channel deposits in the report area are as much as 15 feet thick and are underlain by till and associated sand and gravel deposits. Commonly the channel deposits are mantled by a thin layer of alluvium of Recent age or slopewash. Thicker deposits probably underlie the lake in the Des Lacs River valley.

The outwash-channel deposits are very permeable, and many farm and domestic wells draw water from them (fig. 3 and table 3). Where the deposits are thick and coarse grained they will yield considerable quantities of water to wells, but the yields are limited by the areal extent and by the quantity of recharge available to the aquifer. Generally the water is of good quality, although hard.

#### Alluvium of Recent age

Deposits of alluvium of Recent age are found in the valley of the Des Lacs River and at the mouths of its principal tributaries. The deposits consist predominantly of fine sand, silt, and clay and some local deposits of sandy gravel, cobbles, and small boulders. The water of the Upper Des Lacs Lake covers most of the deposits, and the exposures are confined to small areas at the mouths of the principal tributaries. Definite information is not available on the thickness of the deposits, but they may be relatively thin; they grade into slopewash on the valley sides and into the underlying deposits of glacial outwash. The sandy and gravelly parts of the alluvium are permeable but the silty or clayey parts are nearly impermeable. The alluvial deposits in the Bowbells area are not known to yield water to wells.

## Recharge, Movement, and Discharge of Ground Water

The aquifers in the Bowbells area are mainly recharged by precipitation. Water from rain or melting snow percolates downward and laterally to replenish aquifers in the drift and bedrock. However, because of the discontinuous and alternating sequence of beds in the Fort Union Formation and because the glacial drift is rather impermeable, natural recharge is slow. Artificial discharge by wells, unless accompanied by equal or greater recharge, tends to lower ground-water levels rapidly. Probably the greatest amount of recharge to the bedrock aquifers is by lateral migration of water into the area.

Recharge is influenced by the permeability of the surficial deposits, the amount and duration of precipitation, and the season in which the precipitation occurs. Primary recharge areas are lakes, marshes, sloughs, and areas of permeable surficial deposits.

The regional movement of ground water in the bedrock aquifers appears to be northeastward. Locally in both drift and bedrock aquifers, the direction of movement is controlled by topography, dip of the bedrock surface, local drainage systems that are areas of ground-water discharge, and local differences in the permeability and transmissibility of the aquifers.

Ground-water discharge is the withdrawal or loss of water from the ground-water reservoir. The water is removed by evapotranspiration, by flow into streams, springs, seeps, by underflow that leaves the area, and by pumping from wells.

## QUALITY OF WATER

Water dissolves a part of the mineral constituents of the rock particles as it moves toward and through an aquifer. The amount of material dissolved depends principally on the amount of soluble materials with which the water has contact, the length of time of the contact, and the amount of carbon dioxide in the water. In a homogeneous aquifer water that has been stored a long time or has traveled a long distance from the recharge area generally is more mineralized than water that has been stored a short time or has been recovered relatively near the recharge area of the aquifer.

Chemical analyses of water samples from glacial drift and bedrock in the Bowbells area are listed in table 2. Analyses of water from the glacial drift show extreme variability in chemical quality. The water from medium to coarse-grained deposits, for example water from a shallow well (161-89-3bcb), has a relatively low dissolved-solids content. Water from well 162-89-3ada, which taps a sand and gravel lens enclosed in the till, has a dissolved-solids content of more than 1,500 ppm. A shallow well (162-90-10cbc) tapping fine-grained deposits (till) has an extremely high dissolved-solids content and hardness (table 2). Although the water from glacial-drift aquifers is generally hard, it is more desirable for drinking and culinary purposes than water from the bedrock formations.

Eight Chemical analyses of water from the Fort Union Formation are listed in table 2. In three of the analyses sodium determinations were not made, but the data suggest that sodium was the predominant cation. If so, four of the Fort Union Formation water samples are of the sodium bicarbonate type and four are of the sodium sulfate type. However, LaRocque, Swenson, and Greenman, (1951, p. 65) classify water from the Fort Union Formation into the following types: a hard calcium sulfate water generally obtained from shallow wells, and a soft sodium bicarbonate water normally obtained from the deeper wells. The soft water tastes like a mild solution of baking soda. Some of the water is brown -- especially water from aquifers associated with lignite beds.



The quality of water for public supply and domestic use commonly is evaluated in relation to standards of the U.S. Public Health Service for drinking water. The standards, adopted in 1914 to protect the health of the traveling public, were revised several times in subsequent years. The latest revisions by the U.S. Public Health Service (1961), approved by the Secretary of Health, Education, and Welfare, are, in part as follows:

<u>Constituent</u>	<u>Maximum concentration</u> ppm	
Iron (Fe)-----	0.3	
Manganese (Mn)-----	.05	
Sulfate (SO <sub>4</sub> )-----	250	
Chloride (Cl)-----	250	
Fluoride (F)-----	1.7	<u>a/</u>
Nitrate (NO <sub>3</sub> )-----	45	
Dissolved solids-----	500	<u>b/</u>

a/Based on annual average of maximum daily air temperatures at Bowbells.

b/Dissolved-solids content of 1,000 ppm is permitted if water of better quality is not available.

The data in table 2 show that the recommended maximum limits for some mineral constituents are exceeded in all but one sample; however, water containing more than the recommended mineral concentrations has been used in some areas, including North Dakota, for many years without reported ill effects.

## SUMMARY OF GROUND-WATER CONDITIONS

All ground water used in the Bowbells area is produced from aquifers in the glacial drift or the underlying Fort Union Formation. The aquifers are recharged by infiltration of rain or snowmelt. Recharge to the glacial drift is greatest in lakes, marshes, and slough areas and where the surficial deposits are highly permeable. The recharge, once underground, continues to percolate downward and laterally to replenish aquifers in the till and bedrock. The bedrock is mainly recharged by the lateral migration of ground water into the area. Because of the low permeability of the till, and because of the discontinuous and alternating sequence of beds in the Tongue River Member of the Fort Union Formation, natural recharge is slow and natural discharge accompanied by artificial discharge by wells tends to lower ground-water levels rapidly.

Aquifers in the glacial drift supply water for numerous wells in the Bowbells area. Sufficient water supplies for farm and domestic use ordinarily can be obtained from sand and gravel aquifers in the outwash deposits, from small lenticular sand and gravel aquifers within the till, or from the discontinuous deposits at the base of the glacial drift. Generally the water is hard, but residents prefer it to water from the Fort Union Formation for drinking and culinary purposes. The drift aquifers cannot sustain heavy pumping because they are small and because they grade into and are enclosed by materials of low permeability. Sand and lignite beds in the Tongue River Member of the Fort Union Formation are the source of water for many wells in the Bowbells area. The municipal system at Bowbells, the residents in the communities of Northgate and Coteau, and numerous farmsteads are supplied by wells in these aquifers. The range of the dissolved-solids content in water from the Fort Union Formation as shown by the analyses in table 2 is from 1,670 to 2,150 ppm.

The Cannonball Member of the Fort Union Formation of Paleocene age and the Dakota Sandstone, Fox Hills(?) Sandstone, and Hell Creek Formation of Cretaceous age are aquifers in other areas of North Dakota; however, in the Bowbells area, the formations are relatively deep and are not major sources of water at the present time (1962).

The ground-water supply is sustained by recharge from precipitation. Droughts influence the quantity and may affect the quality of water available to wells; to insure a perennial water supply from ground water, therefore, conservation measures will be needed as withdrawal increase.

TABLE 2.--Chemical

Geologic source: Qd, glacial drift; Tf, Fort Union Formation

Results in parts per million except as indicated

Well number	Owner or name	Geologic source	Depth of well (feet)	Date of collection	Source of analysis	Silica (SiO <sub>2</sub> )	Iron (Fe)	Calcium (Ca)	Magnesium (Mg)	Sodium (Na)	Potassium (K)
<u>161-89</u>											
3bcb	Peter Thompson	Qd	14	1950	A	...	0.15	65	24	...	...
5acc2	City of Bowbells	Tf	710	1950	A	...	.19	8	3	...	...
5acc3	..do....	Tf	227	1950	A	...	.2	7	3	...	...
5dab	Test hole 331	Tf	100	9-22-50	A	...	.14	53	19	...	...
16bcc	Test hole 532	Tf	300	5-29-52	A	...	2.2	79	29	447	...
26dca	Jorgen Hansen	Tf	237	6- 6-47	B	14	.27	8.5	5.0	763	2.4
<u>161-90</u>											
11cdc	Carl Melby	Tf	89	6- 2-48	B	24	.00	249	45	440	12
<u>162-89</u>											
3ada	John Owens	Qd	182	6- 5-47	B	25	.05	93	44	391	17
18add	Hilbert Pfeifer	Tf	200	5-29-48	B	3.5	.05	28	15	508	11
31daa	Albert Olson	Tf	270	9-11-48	B	11	.02	7.5	4.8	752	2.0
35dcc	Arnold Anderson	..	...	6- 6-47	B	20	.1	235	54	400	18
<u>162-90</u>											
10cbc	U.S. Bureau of Reclamation test hole	Qd	22.5	8-28-51	B	16	...	407	2,410		2,720
<u>163-89</u>											
8add	R. G. Emerson	Qd	153	6- 5-47	B	13	.05	45	21	729	3.2
25ada	George Swenson	Qd	200	6- 2-48	B	2.5	.80	36	21	978	15

analyses of ground water

Source of analysis: A, State Laboratories,  
Bismarck, N. Dak., B, U.S. Geological  
Survey, Lincoln, Nebr.

Bicarbonate (HCO <sub>3</sub> )	Carbonate (CO <sub>3</sub> )	Sulfate (SO <sub>4</sub> )	Chloride (Cl)	Fluoride (F)	Nitrate (NO <sub>3</sub> )	Boron (B)	Hardness as CaCO <sub>3</sub>	Dissolved solids (calculated)	Percent sodium	Specific con- ductance (micromhos per cm. at 25°C)	pH
184	24	63	...	...	0.02	...	262	....	..	.....	...
1,400	...	28	313	...	.01	...	34	....	..	.....	...
1,010	209	5	158	...	.01	...	28	....	..	.....	...
544	96	861	26	...	.02	...	211	....	..	.....	...
642	...	711	18	...	21.7	...	316	....	75	.....	7.8
964	24	814	36	1.4	1.8	0.27	42	2,150	97	3,090	8.3
650	0	1,120	18	.2	2.4	.42	806	2,240	54	2,640	7.1
576	33	593	72	.6	3.0	.55	413	1,560	66	2,090	8.0
202	0	1,000	6.0	.7	.0	.38	132	1,670	88	2,360	7.7
1,680	0	6.4	186	1.4	.0	.17	38	1,810	98	2,530	7.9
500	0	1,170	16	.4	1.5	.54	808	2,160	51	2,350	...
805	0	15,400	107	2.0	1.1	...	10,900	21,500	35	18,400	7.8
844	35	872	58	.6	1.5	.46	199	2,200	89	3,330	8.4
566	5	1,710	34	.6	1.6	.40	176	3,080	92	4,070	8.1

TABLE 3.--Records

Depth of well and depth to water: Measured  
depths given in feet, tenths, and hundredths;  
reported depths given in feet.

Type of well: Dr, drilled; Du, dug.

Location No.	Owner or name	Depth of well (feet)	Diameter or size (inches)	Type	Date completed	Depth to water below land surface(feet)
<u>161-88</u>						
5aba	Test hole 541	110	5	Dr	6-21-52	.....
5bab	Test hole 540	250	5	Dr	6-19-52	.....
5bb	Vacant	...	4	Dr	.....	87.49
5bbb	Test hole 539	340	5	Dr	6-10-52	.....
6aal	Floyd Bryan	285	2½	Dr	.....	100
6aa2	..do....	25	18	Dr	.....	8.50
6bbb	Vacant	12	48	Du	.....	4.98
17cac1	Martin Peterson	296	3	Dr	.....	135.00
17cac2	..do....	11.2	42	Du	.....	9.80
17cca	..do....	275	3	Dr	.....	145
18bdd1	Vacant	...	4	Dr	.....	109.00
18bdd2	..do....	22	6	Du	.....	9.71
20bab1	Arthur H. Hanson	...	4	Dr	.....	125
20bab2	..do....	24.40	6	Dr	.....	14.17
29ddd	C. R. Johnson	19.00	48	Du	.....	6.27
31lcb1	Vacant	...	4	Dr	.....	145.61
31lcb2	..do....	32	30	Du	.....	10.95
<u>161-89</u>						
1lcb	Bowbells Golf Club...	20	8	Dr	.....	7.24
1ccd	Vacant	20	8	Dr	.....	16
2bbb	John E. Cook	12	48	Du	.....	8.31
3bbb	Albert Dahlmie	90	4	Dr	.....	6.56
3lcb	Peter Thompson	14+	96	Du	.....	8.91
3dcl	Carl Swenson	94	4	Dr	.....	39.07
3dcc2	..do....	16	5	Dr	.....	6.52
4aaa1	Test hole 10	22	5	Dr	.....	.....
4aaa2	..do....	60	5	Dr	6- 2-52	.....
4bbb	Charles Speer	30	24	Du	.....	7.95
4bcc	Peter Thompson	92	4	Dr	.....	20.67

of wells and test holes

Use of water: D, domestic; N, none; Obs, observation; PS, public supply; S, stock; T, test hole.

Geologic source: Tf, Fort Union Formation; Qd, glacial drift.

Date of measurement	Use of water	Geologic source	Altitude of land surface (feet)	Remarks
.....	T	...	1,815	See log.
.....	T	...	1,820	..Do....
10- 2-46	N	...	1,922	
.....	T	...	1,920	..Do....
9-18-45	S	Tf	1,919	Supply reported adequate; rust particles.
9-18-45	D	Qd	1,919	Supply reported small.
10- 2-46	S	Qd	1,910	
10- 2-46	S	Tf	1,922	Supply reported adequate.
10- 2-46	D	Qd	1,918	Supply reported small.
10- 2-46	N	Tf	1,925	
10- 2-46	N	...	1,941	
10- 2-46	N	Qd	1,943	
10- 2-46	S	...	1,921	Supply reported adequate.
10- 2-46	D	Qd	1,921	Supply reported small.
7- 7-47	D,S	Qd	1,947	Supply reported adequate.
10- 2-46	N	...	1,963	
10- 2-46	N	Qd	1,959	
11- 7-50	PS	Qd	1,932	Supply reported small.
9-24-45	D	Qd	1,932	..Do....
7-31-46	S	Qd	1,938	
7-31-46	S	...	1,940	
7-31-46	PS	Qd	1,931	See chemical analysis.
7-15-46	S	Tf	1,949	Supply reported adequate.
7-15-46	D	Qd	1,932	
.....	T	...	.....	See log.
.....	T	...	1,946	..Do....
7-31-46	N	Qd	1,950	
7-12-46	N	Tf	1,955	



TABLE 3.--Records

Location No.	Owner or name	Depth of well (feet)	Diameter or size (inches)	Type	Date completed	Depth to water below land surface (feet)
161-89(Cont.)						
4ccc	Test hole 531	50	5	Dr	5-26-52	.....
5aac	City of Bowbells	70	...	Dr	1910	.....
5aad	Test hole 548	600	5	Dr	7-16-52	.....
5acc1	City of Bowbells	230	8	Dr	1935	65
5acc2	..do....	710	12	Dr	1945	110
5acc3	..do....	227	8	Dr	1936	220
5bbb	Test hole 546	40	5	Dr	7-10-52	.....
5bcc	Test hole 5	21	5	Dr	.....	.....
5cad1	Test hole 8	17	5	Dr	.....	.....
5cad2	Test hole 9	17	5	Dr	.....	.....
5cb	Missouri-Souris test hole	65	4 3/4	Dr	1947	3.00
5cbcl	Test hole 1	67	5	Dr	.....	.....
5cbc2	Test hole 2	21	5	Dr	.....	.....
5cdal	Test hole 6	17	5	Dr	.....	.....
5cda2	Test hole 7	17	5	Dr	.....	.....
5dab	Test hole 331	100	5	Dr	9-21-50	.....
5ddc1	L. P. Christianson	97	4	Dr	.....	23.02
5ddc2	..do....	80	5	Dr	.....	22.79
6ccd	Mrs. W. Gorman	58	6	Dr	.....	20.63
6daal	Test hole 3	17	5	Dr	.....	.....
6daa2	Test hole 4	12	5	Dr	.....	.....
6dad	Federal Land Bank	70	...	Dr	.....	.....
8baa	John Cook	100	5	Dr	.....	24.32
8cbb	A. Fisher	102	5	Dr	.....	27.53
9bbb1	A. G. Wiper	...	6	Dr	.....	23.94
9bbb2	..do....	190	4	Dr	.....	.....
9bcc	Test hole 530	115	5	Dr	5-24-52	.....
10ddd	Christ Olson	273	3	Dr	.....	130
11daa	Test hole 542	327	5	Dr	6-23-52	.....
12bbb	L. Anderson	112	2	Dr	.....	.....
13ccc	Wm. Quanbeck	170	6	Dr	.....	116.92
13ddc	Vacant	...	6	Dr	.....	118.45
14aaa	A. C. Thompson	120	5	Dr	.....	26.05
14cdd	J. P. Neve	12	...	Du	.....	8.81
14dad	Pete Jordy	285	4	Dr	.....	100

of wells and test holes -- Continued

Date of measurement	Use of water	Geologic source	Altitude of land surface (feet)	Remarks
.....	T	...	1,962	See log.
7-12-52	N	Tf	.....	Dark-brown color.
.....	T	...	1,956	See log.
7-12-52	PS	Tf	1,957	
9-18-45	PS	Tf	1,957	See chemical analysis.
6- 6-47	PS	Tf	1,957	..Do....
.....	T	...	1,955	See log.
.....	T	...	1,945	..Do....
.....	T	...	1,940	..Do....
.....	T	...	1,940	..Do....
8-25-47	T	...	1,948	..Do....
.....	T	...	1,955	..Do....
.....	T	...	1,953	..Do....
.....	T	...	1,950	..Do....
.....	T	...	1,940	..Do....
.....	T	Tf	1,952	See log; chemical analysis.
7-12-46	D,S	Tf	1,956	Supply reported adequate.
7-12-46	N	Tf	1,956	
7-12-46	N	Tf	1,961	
.....	T	...	.....	See log.
.....	T	...	1,941	..Do....
6- 9-47	S	Tf	1,956	Brown color.
7-12-46	N	Tf	1,956	
7-12-46	N	Tf	1,963	
7-12-46	S	Tf	1,959	Supply reported adequate.
6- 6-47	S	Tf	1,960	
.....	T	...	1,961	See log.
7-15-46	S	Tf	1,955	Supply reported adequate.
.....	T	...	1,940	See log.
8- 1-46	N	Tf	1,941	
8- 1-46	S	Tf	1,956	
8- 1-46	N	...	1,951	
7-15-46	S	Tf	1,947	
11- 7-50	D,Obs	...	1,949	
7-15-46	S	Tf	1,957	

TABLE 3.--Records

Location No.	Owner or name	Depth of well (feet)	Diameter or size (inches)	Type	Date completed	Depth to water below land surface (feet)
161-89(Cont.)						
14ddd	Test hole 5 <sup>1</sup> / <sub>3</sub>	140	5	Dr	7- 3-52	.....
15ccc	Ole Berg	160	6	Dr	.....	65.90
16bbb	Test hole 529	295	5	Dr	5-22-52	.....
16bcb	Test hole 5 <sup>1</sup> / <sub>5</sub>	180	5	Dr	7- 9-52	.....
16bcc	Test hole 532	300	5	Dr	5-26-52	51.49
16cbc	Test hole 5 <sup>1</sup> / <sub>4</sub>	120	5	Dr	7- 8-52	.....
16ccc	Test hole 533	100	5	Dr	5-31-52	.....
18cbc	Vacant	11+	16	Du	.....	6.84
18cca	..do....	...	48	Du	.....	8.28
19daa	Art Olson	180	6	Dr	.....	29.07
20aaa	T. Jacobson	96	5	Dr	.....	24.30
20add	Test hole 53 <sup>4</sup> / <sub>4</sub>	80	5	Dr	6- 2-52	.....
20dab	Sam Knutson	27	52	Du	.....	8.12
21bab1	Tom Jacobson	150	...	Dr	.....	47.03
21bab2	..do....	15	8	Du	.....	10.02
21dad	F. F. Haenhouse	100	5	Dr	.....	39.45
23aaa	D. Bystedt	180	4	Dr	.....	70
23ccc	Sam Knutson	170	6	Dr	.....	64.55
24bbc	Olson Bros.	180	6	Dr	.....	25.38
24cbb	H. C. Olson	180	6	Dr	.....	103.98
24ddd	Richard Hanson	600	3	Dr	.....	120
25bcb1	H. G. Hanson	27 <sup>1</sup> / <sub>4</sub>	4	Dr	.....	130
25bcb2	..do....	35	36	Du	.....	9.50
26ccc1	Mrs. C. Carlson	265	3	Dr	.....	153.22
26ccc2	..do....	24	42	Du	.....	10.50
26dca	Jorgen Hansen	237	3	Dr	.....	150
27aaa	Vacant	...	6	Dr	.....	124.04
27bbb1	H. H. Hanson	136	10	Dr	.....	39.95
27bbb2	..do....	23	36	Du	.....	13.36
27ddd	L. P. Christianson	220	5	Dr	.....	76.32
28aaa1	Fred Hanson	100	3	Dr	.....	.....
28aaa2	Vacant	...	3	Dr	.....	120
28bcb	Arthur Ekstrom	75	6	Dr	.....	16.17
28ddd	Ed. Lindquist	24	48	Du	.....	16.62
29ccb	Frank Lieichtnam	22	48	Du	.....	18.19

of wells and test holes -- Continued

Date of measurement	Use of water	Geologic source	Altitude of land surface (feet)	Remarks
.....	T	...	1,958	See log.
7-13-46	D,S	Tf	1,971	Supply reported adequate.
.....	T	...	1,945	See log.
.....	T	...	1,950	..Do....
5-31-52	T	Tf	1,960	See log; chemical analysis.
.....	T	...	1,968	See log.
.....	T	...	1,971	..Do....
7-12-46	N	Qd	1,958	
11- 7-50	S,Obs	Qd	1,964	
7-12-46	D,S	Tf	1,975	Supply reported adequate.
11- 7-50	Obs	Tf	.....	
.....	T	...	1,972	See log.
7-12-46	D,S	Qd	1,970	Supply reported adequate.
7-12-46	S	Tf	1,971	Supply reported adequate; brown color.
7-12-46	D	Qd	1,971	
7-13-46	S	Tf	1,973	Light-brown color.
8- 1-46	S	Tf	1,961	Supply reported adequate.
7-15-46	S	Tf	1,972	
7-15-46	N	Tf	1,953	
8- 1-46	S	Tf	1,962	
7-15-46	N	Tf	1,955	Soft.
7-15-46	S	Tf	1,966	Supply reported adequate.
7-15-46	N	Qd	1,966	
7-13-46	S	Tf	1,971	..Do....
7-13-46	D	Qd	1,971	..Do....
7-15-46	S	Tf	1,972	Supply reported adequate; see chemical analysis.
8- 1-46	N	...	1,966	
7-13-46	N	Tf	1,976	
7-13-46	N	Qd	1,976	
11- 7-50	Obs	...	1,965	
8- 1-46	N	...	1,972	
8- 1-46	S	Tf	1,971	Supply reported adequate.
7-13-46	N	...	1,970	
4-22-47	Obs	Qd	1,982	
4-22-47	D,Obs	Qd	1,985	

TABLE 3.--Records

Location No.	Owner or name	Depth of well (feet)	Diameter or size (inches)	Type	Date completed	Depth to water below land surface (feet)
<u>161-89(Cont.)</u>						
30bad	Alfred Sagnes	30	36	Du	.....	15.50
31aca	Vacant	21	48	Du	.....	16.22
32aad	Alfred Johnson	24	24	Du	.....	15.47
33bbb	I. A. Sageness	24	48	Du	.....	16.35
33ddd	F. Johnson	46	14	Du	.....	12.02
34dad	Wilfred I. Helms	300	4	Dr	.....	100
35bab1	R. A. Anderson	27	24	Du	.....	12.38
35bab2	..do....	27	36	Du	.....	11.42
36dd	Missouri-Souris test hole	315	4 3/4	Dr	7 -47	5.10
<u>161-90</u>						
1bbb	Mrs. E. Buckrud	180	4	Dr	.....	19.75
2bad	Raymond Mattson	261	5	Dr	.....	29.13
2ddb	Vacant	31	12	Dr	.....	16.29
3ddd	G. Nelson	187	6	Dr	.....	50
11cdc	Carl Melby	89	5	Dr	.....	8.58
12aba	Vacant	...	4	Dr	.....	8.29
12bcc	.....	...	4.8	Du	.....	20.68
12cbc	M. Hanson	30	30	Dr	.....	25.34
12daa	P. L. Hanson	13	4.8	Du	.....	0.18
13abb	Mike Mertes	30	4.8	Du	.....	18.91
14aaa	Vacant	125	6	Dr	.....	19.93
14daa	Carl A. Johnson	48	4	Dr	.....	15
15bcc	Myre Epton	20	24	Du	.....	13.99
15dcc	Vacant	...	4	Dr	.....	24.58
22bba	Mrs. Edith Wahlund	31	24	Dr	.....	23.97
22cdc	Harry Olson	43	24	Du	.....	35.08
22dcc	Louis Sundin	60	4	Dr	.....	29.80
23bba	Vacant	22	36	Du	.....	19.45
23bcd	John Chrest	...	18	Dr	.....	29.94
23dbb	H. Haroldson	200	3	Dr	.....	40
24aaa1	S. Ross	63	4	Dr	.....	18
24aaa2	M. Ross	30	4.8	Du	.....	11.12
24bdc	Emil Johnson	20	36	Du	.....	5.66
24cbb	Aden Nelson	24	36	Du	.....	9.14
25bab1	Fred Bornstedt	30	4.2	Du	.....	16.72

of wells and test holes -- Continued

Date of measurement	Use of water	Geologic source	Altitude of land surface (feet)	Remarks
7-12-46	S	Qd	1,984	Supply reported adequate.
7-12-46	N	Qd	2,004	
7-13-46	D,S	Qd	1,984	..Do....
7-13-46	D,S	Qd	1,981	..Do....
7-13-46	S	Qd	1,977	
7-13-46	S	Tf	1,965	..Do....
7-13-46	S	Qd	1,972	..Do....
7-13-46	D	Qd	1,973	..Do....
8-13-47	T	...	1,962	See log.
8- 1-46	N	Tf	1,952	
7-16-46	D,S	Tf	1,956	Supply reported adequate.
7-11-46	N	...	1,958	
9-15-45	D,S	Tf	1,956	..Do....
7-11-46	N	Tf	1,958	See chemical analysis.
7-11-46	S	Tf	1,959	
7-11-46	S	Qd	1,971	
7-11-46	S	Qd	1,970	
4-22-47	Obs	Qd	1,963	
7-11-46	D,S	Qd	1,973	Supply reported adequate.
7-11-46	S	Tf	1,970	
7-11-46	D,S	Tf	1,966	..Do....
7-10-46	S	Qd	1,977	
7- 9-46	N	Tf	1,995	
7- 9-46	S	Qd	1,896	
7- 9-46	D,S	...	1,931	..Do....
7- 9-46	S	Tf	2,021	
7-11-46	N	Qd	1,985	
4-22-47	D,S	Qd	1,997	
	Obs			
7-11-46	D,S	Tf	1,990	..Do....
7-12-46	D,S	Tf	1,976	..Do....
7-12-46	N	Qd	1,970	
7-11-46	N	Qd	1,972	
7-11-46	S	Qd	1,974	..Do....
7-11-46	S	Qd	1,986	

TABLE 3.--Records

Location No.	Owner or name	Depth of well (feet)	Diameter or size (inches)	Type	Date completed	Depth to water below land surface (feet)
<u>161-90(Cont.)</u>						
25bab2	Fred Bornstedt	11	18	Du	.....	6.31
26bab	France Linstrom	190	5	Dr	.....	30.33
26cab	Vacant	...	6	Dr	.....	27.21
34ddd	T. H. Thompson	22	36	Du	.....	11.68
35adc	Walfred Olson	40	42	Du	.....	31.61
35cdc	Edna Olson	72	3	Dr	.....	25.52
<u>162-88</u>						
7cba	Ed Hedstrup	180	2	Dr	.....	.....
17bbb	Unknown	260	4	Dr	.....	60
18ccb	A. E. Kerkelie	320	3	Dr	.....	80
19bba	B. Dahle	18	48	Du	.....	12.70
20bca	Howe Denny	8	48	Du	.....	6.91
30ccb	Unknown	13	10	Du	.....	7.16
30ccc	..do....	18	24	Du	.....	5.44
31ladd	Mrs. L. Durwood	248	6	Dr	.....	45
31ccc	R. F. Dodge	10	48	Du	.....	3.45
31cdc	Test hole 538	303	5	Dr	6- 5-52	.....
31ddc	W. C. Mitchell	283	4	Dr	.....	80.50
<u>162-89</u>						
1bbd	Raymond Swenson	18	48	Du	.....	8.52
1ddb	Albert Haas	12	60	Du	.....	6.55
2cdc	Vacant	69	4	Dr	.....	Dry
2ddd1	Simon Lynch	20	48	Du	.....	8.59
2ddd2	..do....	14	24	Du	.....	8.07
3ada	John Owens	182	2	Dr	.....	100
3cdc	John Auffort	160	2	Dr	.....	.....
4bbb	Test hole 327	284	5	Dr	8-22-50	.....
4cdc	Vacant	7	48	Du	.....	3.45
5aaa1	Smith Estate	378	2 $\frac{1}{2}$	Dr	.....	90
5aaa2	..do....	42	48	Du	.....	28.56
5ddd1	Mrs. P. Peterson	8	36	Du	.....	5.46
5ddd2	..do....	394	3	Dr	1910	69.60
6ada	Siverling Estate	196	6	Dr	.....	8.66
7cdd	E. K. Melby	150	2	Dr	.....	.....
8aaa	Test hole 326	430	5	Dr	8-17-50	.....

of wells and test holes -- Continued

Date of measurement	Use of water	Geologic source	Altitude of land surface (feet)	Remarks
7-11-46	N	Qd	1,984	
7-11-46	D,S	Tf	2,001	Supply reported adequate.
7-10-46	N	...	1,993	
11- 7-50	N	Qd	2,053	
7-11-46	D,S	Tf	2,030	..Do....
7-11-46	D,S	Tf	2,047	..Do....
7-24-46	S	..	1,902	..Do....
9-18-45	D,S	Tf	1,899	..Do....
7-24-46	S	...	1,912	..Do....
7-24-46	S	Qd	1,916	
7-24-46	N	Qd	1,910	
7-29-46	D,S	Qd	1,907	..Do....
7-29-46	D,S	Qd	1,910	..Do....
7-24-46	D,S	Tf	1,927	..Do....
9-18-45	D,S	Qd	1,915	
.....	T	...	1,900	See log.
7-29-46	S	...	1,922	Supply reported adequate.
11- 9-50	D,S			
	Obs	Qd	1,907	
7-24-46	S	Qd	1,901	
9-18-45	N	...	1,917	
7-29-46	N	Qd	1,908	
7-29-46	N	Qd	1,909	
7-29-46	D,S	Qd	1,921	Supply reported adequate; see chemical analysis.
7-29-46	N	Qd	1,924	
.....	T	...	1,911	See log.
11- 7-50	Obs	Qd	1,904	
9-17-45	S	Tf	1,916	
7- 7-47	Obs	Qd	1,917	
7-30-46	N	Qd	1,908	
8-15-51	Obs	Tf	1,921	Temperature 42°F.
7-30-46	D,S	Tf	1,931	Supply reported adequate.
7-27-46	S	Qd	1,940	
.....	T	...	1,907	See log.



TABLE 3.--Records

Location No.	Owner or name	Depth of well (feet)	Diameter or size (inches)	Type	Date completed	Depth to water below land surface (feet)
162-89(Cont.)						
8bcc	T. H. Aierson	...	6	Dr	.....	74.85
8add	John C. Walleen	460	6	Dr	.....	51.27
9abb	Alvin Hass	265	3	Dr	.....	70
10ccc	Vacant	...	6	Dr	.....	10.31
11bbb	Unknown	25	...	Du	.....	1.87
12dcc	Elzor Matte	12	4.2	Du	.....	5.90
13bcc	Fritz Siemens	279	2	Dr	.....	60
13cc	Missouri-Souris test hole	250	4 $\frac{1}{4}$	Dr	7 -47	16.63
13ddd	Unknown	...	3	Dr	.....	6.43
14aab	D.D. Billesland	14	...	Du	.....	10
15bcb1	Andrew Zacharias	280	2	Dr	.....	60
15bcb2	..do....	18	6	Dr	.....	13.13
16bbc	Test hole 325	218	5	Dr	8-15-50	.....
17aad	Frank Schultz	10	4.8	Du	.....	4.53
17ccc	Vacant	...	6	Dr	.....	30.95
18add	Hilbert Pfeifer	200	4	Dr	.....	59.79
18ccc	Vacant	...	2 $\frac{1}{2}$	Dr	.....	2.58
18dad	P. J. Stuckey	200	6	Dr	.....	45.04
19dda	H. W. Anderson	...	5	Dr	.....	56.87
20add	John E. Cook	120	5	Dr	.....	59.10
21add	Albert Klein	90	4	Dr	.....	38
21bbb	Test hole 324	170	5	Dr	8-11-50	.....
21bcc	Arthur Reich	76	4	Dr	.....	56.51
21daa	Albert Klein	12	2.4	Du	.....	4.45
22add1	Frank H. Redmer	120	3	Dr	.....	30
22add2	..do....	9	60	Du	.....	6.91
22ccc	Frank Dyer	81	5	Dr	.....	53.53
25aba	A. Smith	180	2	Dr	.....	101.40
26bda	Vacant	...	8	Dr	.....	10.83
28bcd	Mary L. Corey	160	4	Dr	.....	30
28dd	Missouri-Souris test hole	145	4 3/4	Dr	7 -47	3.69
29aaa	Test hole 323	230	5	Dr	8- 9-50	.....
29ccc	Walt. Speise	100	2	Dr	.....	.....
29ddd	Vacant	...	5	Dr	.....	19.63
30dcc	Jake Engelhart	150	5	Dr	.....	17.51
31bbb	Vacant	...	2.4	Du	.....	12.71

of wells and test holes -- Continued

Date of measurement	Use of water	Geologic source	Altitude of land surface (feet)	Remarks
7-30-46	N	...	1,935	
7-30-46	S	Tf	1,927	Supply reported adequate.
7-30-46	S	Tf	1,913	..Do....
7-30-46	N	...	1,911	
4- 8-47	D,Obs	Qd	1,917	
7-24-46	S	Qd	1,903	..Do....
7-29-46	D,S	Tf	1,913	..Do....
7-14-47	T	...	1,920	See log.
7-16-46	S	...	1,917	
9-18-45	D	Qd	1,912	
7-30-46	D	Tf	1,920	Supply reported adequate.
7-30-46	D	Qd	1,923	..Do....
.....	T	...	1,920	See log.
11- 7-50	D	Qd	1,917	
7-31-50	N	...	1,944	
7-31-50	S	Tf	1,930	Supply reported adequate; see chemical analysis.
4- 8-47	N	...	1,939	
7-31-46	N	...	1,940	Abandoned.
7-31-46	N	...	1,941	..Do....
7-30-46	N	...	1,910	..Do....
7-30-46	S	Qd	1,934	Supply reported adequate.
.....	T	...	1,935	See log.
7-30-46	D,S	Qd	1,935	Supply reported adequate.
7-30-46	D	Qd	1,931	..Do....
7-29-46	S	Qd	1,917	..Do....
7-29-46	D	Qd	1,915	..Do....
11- 7-50	N	Tf	1,917	
10-22-46	N	...	1,919	
7-29-46	S	...	1,929	
7-30-46	S	Tf	1,940	
7-14-47	T	...	1,941	See log.
.....	T	...	1,940	..Do....
7-31-46	N	...	1,951	
7-30-46	N	...	1,943	Abandoned.
7-31-46	S	Tf	1,957	Supply reported adequate.
7-16-46	N	Qd	1,952	

TABLE 3.--Records

Location No.	Owner or name	Depth of well (feet)	Diameter or size (inches)	Type	Date completed	Depth to water below land surface (feet)
<u>162-89 (Cont.)</u>						
31daa	Albert Olson	270	3	Dr	1926	20.98
32dcc	Vacant	...	6	Dr	.....	24.16
33bbb	Test hole 322	80	5	Dr	8- 8-50	.....
33ccc	Carl Aufforth	47	2 $\frac{1}{2}$	Du	.....	24.34
33dcd	D. C. Landis	68	6	Dr	.....	17
3 <sup>h</sup> abb	Gunther Harms	...	4	Dr	.....	56.48
3 <sup>h</sup> ccc	A. J. Bollsmayer	83	2	Dr	.....	10
3 <sup>h</sup> dcc	Siemers Estate	232	5	Dr	.....	55.96
35bca	Clarence Wilkes	10	36	Du	.....	7.19
35ccc	Test hole 536	90	5	Dr	6- 3-52	.....
35dcc	Arnold Anderson	...	4	Dr	.....	33.86
35ddd	Test hole 537	120	5	Dr	6- 4-52	.....
<u>162-90</u>						
1dccc	G. Strawbridge	45	2 $\frac{1}{2}$	Du	.....	35.11
3ddd	U. Donahue	230	4	Dr	.....	92.34
10aad1	Lee Carter	40	2 $\frac{1}{2}$	Dr	.....	14.84
10aad2	..do....	23	2 $\frac{1}{2}$	Dr	.....	7.98
10cbc	U.S. Bureau of Reclamation test hole	22.5	1 $\frac{1}{4}$	Dr	9 -49	8.52
10dcd	Sadie E. Huff	64	18	Dr	.....	13.11
11add	Unknown	225	2	Dr	.....	9.64
11cccl	J. J. Kellogg	170	2	Dr	.....	8.34
11ccc2	..do....	...	..	Du	.....	2.80
13dda	Unknown	10.9	2 $\frac{1}{2}$	Du	.....	3.92
15bbb	C. G. Whitman	40	2 $\frac{1}{2}$	Dr	.....	8.79
15ccc	Mrs. J. Bushe	236	2	Dr	.....	.....
15dccc1	Jake Nygaard	60	6	Dr	.....	40
15dccc2	..do....	23	2 $\frac{1}{2}$	Du	.....	8.39
22add	P. Christenson	40	30	Du	.....	22.22
23ada	O. Ferm	25	2 $\frac{1}{2}$	Dr	.....	18.71
23bdd	Unknown	60	2 $\frac{1}{2}$	Du	.....	16.81
24aaa	C. Peterson	190	3	Dr	.....	4.52
24ddd	Jens Briggs	...	2 $\frac{1}{2}$	Du	.....	11.49
25dcd	Roy J. Peterson	...	2	Dr	.....	2.52
26add	P. M. Lellan	...	6	Dr	.....	9.84

of wells and test holes -- Continued

Date of measurement	Use of water	Geologic source	Altitude of land surface (feet)	Remarks
7-31-46	D,S	Tf	1,956	Supply reported adequate; see chemical analysis.
5- 8-48	N	...	1,950	
.....	T	...	1,949	See log.
7-31-46	S	Qd	1,955	
7-31-46	D,S	Qd	1,948	Supply reported adequate.
7-30-46	D,S	Qd	1,941	..Do....
7-31-46	S	Qd	1,947	..Do....
7-31-46	S	...	1,946	..Do....
7-30-46	D,S	Qd	1,933	
.....	T	...	1,937	See log.
7-31-46	S	...	1,936	Supply reported adequate; see chemical analysis.
.....	T	...	1,933	See log.
7-16-46	N	Qd	1,934	
6-29-49	S	Tf	1,953	Supply reported adequate.
7-10-46	S	Qd	1,949	..Do....
6-29-49	S	Qd	1,949	
11- 7-50	Obs	Qd	1,948	See log; chemical analysis.
7- 3-46	S	Tf	1,950	Supply reported adequate.
6-24-49	D,S	Tf	1,943	..Do....
7-10-46	N	...	1,942	
6-29-49	N	...	1,940	
6- 3-49	S	Qd	1,942	
7- 3-46	N	Qd	1,941	Abandoned.
7- 3-46	S	Tf	1,956	Supply reported adequate.
7- 3-46	S	Qd	1,958	..Do....
7- 3-46	D	Qd	1,953	..Do....
7- 3-46	D,S	Qd	1,960	
7-16-46	D,S	Qd	1,960	
7-16-46	S	Qd	1,953	
8-12-46	N	...	1,947	
7-16-46	D	Qd	1,953	..Do....
7-16-46	N	Tf	1,953	
7-16-46	N	Tf	1,957	

TABLE 3.--Records

Location No.	Owner or name	Depth of well (feet)	Diameter or size (inches)	Type	Date completed	Depth to water below land surface (feet)
<u>162-90(Cont.)</u>						
27dcd	Alfred Jensen	20	30	Du	.....	7.91
34ddd1	Test hole 547	20	5	Dr	7-11-52	.....
34ddd2	Math Funck	45	6	Dr	.....	15.43
34ddd3	..do....	45	24	Dr	.....	14.15
35add	Peter Peterson	55	6	Dr	.....	12.70
35cdc1	Nick Funck	30	42	Du	.....	7.62
35cdc2	..do....	15	42	Du	.....	5.06
36add	Robert J. Magadanz	236	3	Dr	1920	30
<u>163-88</u>						
6dcc	Clarence Jacobson	27	60	Du	.....	25.18
8baa	Henry Moen	200	4	Dr	.....	66.73
8dcc	Joe Freed	35	36	Du	.....	18.58
18cbb1	Arnhold Ludtke	16	36	Du	.....	8.16
18cbb2	..do....	18	36	Du	.....	3.88
19acc	John Kallberg	200	2	Dr	.....	140
19dcc1	Gust T. Swenson	212	3	Dr	.....	48
19dcc2	..do....	14	48	Du	.....	9.59
29bbb	Willard Swenson	180	2	Dr	.....	40
29ddd	Bank of North Dakota	44	3	Dr	.....	.....
30dcd	Ed Neilson	140	2	Dr	.....	50
32baa1	Tony Bauen	180	2	Dr	.....	60
32baa2	..do....	15	48	Du	.....	9.28
32ccb	Earl Owens	80	18	Dr	.....	73.47
<u>163-89</u>						
lacc	U.S. Bureau of Reclamation	20	2	Dr	.....	10.50
lcdb	.....	19	36	Du	.....	15.10
2ddd	U.S. Bureau of Reclamation	11	1 $\frac{1}{2}$	Dr	.....	9.9
4bcb	Dan Burke	90	2	Dr	.....	23
5aaa	Unknown	90	2	Dr	.....	25
5bcc	F. A. Freed	180	2	Dr	.....	90
6bcb	John C. Peterson	110	2	Dr	.....	70
7bcb	Bertha Johnson	200	5	Dr	.....	110
7ddd	M. McIntee	138	4	Dr	.....	8.02

of wells and test holes -- Continued

Date of measure- ment	Use of water	Geologic source	Altitude of land surface (feet)	Remarks
11- 7-50	D,Obs	Qd	1,946	Supply reported adequate.
.....	T	...	1,950	See log.
7- 2-46	D,S	Tf	1,950	Supply reported adequate.
7- 2-46	S	Tf	1,959	..Do....
7-16-46	D,S	Tf	1,962	..Do....
7-10-46	D	Qd	1,956	..Do....
7-10-46	S	Qd	1,905	..Do....
7-16-46	S	Tf	1,951	..Do....
7-26-46	N	Qd	1,856	
7-26-46	D,S	Qd	1,858	..Do....
7-25-46	S	Qd	1,851	..Do....
7-23-46	D	Qd	1,867	..Do....
7-23-46	S	Qd	1,862	..Do....
7-23-46	S	Tf	1,870	Supply reported inadequate.
.....	D,S	Qd	1,874	Supply reported adequate.
11- 9-50	D	Qd	1,874	Supply reported small.
7-23-46	S	Qd	1,869	Supply reported adequate.
.....	N	...	1,862	Plugged at 44 foot depth.
7-23-46	D,S	Qd	1,881	Supply reported adequate.
7-23-46	S	Qd	1,871	..Do....
7-23-46	D	Qd	1,872	..Do....
7-24-46	S	Qd	1,880	..Do....
10-31-50	N	Qd	1,818	
10-31-37	D	Qd	.....	
7-24-51	N	Qd	1,840	
7-18-46	D,S	Qd	1,870	Supply reported adequate.
7-18-46	...	...	1,865	
.....	D,S	...	1,872	..Do....
7-17-46	D,S	Qd	1,837	..Do....
7-17-46	S	Qd	1,901	..Do....
10-22-46	N	...	1,904	

TABLE 3.--Records

Location No.	Owner or name	Depth of well (feet)	Diameter or size (inches)	Type	Date completed	Depth to water below land surface (feet)
163-89(Cont.)						
8add	R. G. Emerson	153	5	Dr	.....	77.97
8bbb	Gust Ganskop	170	4	Dr	.....	100
8ddd	Floyd Swenson	200	5	Dr	.....	68.46
9cdd	Unknown	200	2	Dr	.....	.....
9dcc	J. Andrews	200	2	Dr	.....	.....
10dcb	J. L. Guerdett	12	48	Du	.....	5.96
11acc	U.S. Bureau of Reclamation	9	1 $\frac{1}{4}$	Du	.....	4.57
11adc	Jake Agman	8	36	Du	.....	5.72
11ccc	U.S. Bureau of Reclamation	24	1 $\frac{1}{2}$	Dr	.....	8.63
12ddd	Melvin Mattern	14	30	Du	.....	7.61
13daal	Carl E. Olson	15	36	Du	.....	10.00
13daa2	..do....	11	50	Du	.....	8.72
15abb	C. H. Cornell	20	36	Du	.....	7.75
15acc	U.S. Bureau of Reclamation	16	1 $\frac{1}{4}$	Dr	.....	12.29
16ddd	..do....	13	1 $\frac{1}{4}$	Dr	.....	4.81
17add	Carl Knudson	200	4	Dr	.....	88
17da	Missouri-Souris test hole	300	4 3/4	Dr	7 -47	5.72
18bcb	Ted Harms	142	3	Dr	.....	70
18dad	Thomas Madden	179	4	Dr	.....	.....
21acc	U.S. Bureau of Reclamation	13.50	1 $\frac{1}{4}$	Dr	.....	8.10
21bbb	Test hole 329	240	5	Dr	9-15-50	.....
21bcd	Knutson	300	4	Dr	.....	.....
21cdd	Carl H. Peterson	22	42	Du	.....	16.94
22ccc	P. C. Peterson	250	2 $\frac{1}{2}$	Dr	.....	90.00
23ddd	Mrs. L. Coons	126	2 $\frac{1}{2}$	Dr	.....	60
24ccc	..do....	195	2	Dr	.....	90
24dcd	Hans Hanson	150	4	Dr	.....	50
25ada	George Swenson	200	6	Dr	.....	50.81
25cbc	B. B. Bair	167	2 $\frac{1}{2}$	Dr	.....	40
26aba	Glenn Swenson	120	2	Dr	.....	55
26cdb	Vacant	11	36	Du	.....	6.67

of wells and test holes -- Continued

Date of measurement	Use of water	Geologic source	Altitude of land surface (feet)	Remarks
7-18-46	D,S	Qd	1,892	Supply reported adequate; see chemical analysis.
7-17-46	D,S	Qd	1,896	Supply reported inadequate.
11- 9-45	N	...	1,902	
.....	N	...	1,894	
.....	N	...	1,896	
10- 9-45	D,S	Qd	1,881	Supply reported adequate.
7-24-50	N	Qd	1,864	
7-19-46	D,S	Qd	1,856	..Do....
7-24-49	N	Qd	1,882	
7-18-46	D,S	Qd	1,843	Supply reported small.
7-23-46	D,S	Qd	1,867	Supply reported adequate.
7-23-46	S	Qd	1,866	..Do....
7-18-46	D,S	Qd	1,884	..Do....
5- 9-51	N	Qd	1,889	
7-24-51	N	Qd	1,888	
7-18-46	D,S	Qd	1,902	
7- 1-47	T	...	1,940	See log.
7-17-46	S	...	1,915	Supply reported inadequate.
.....	N	...	1,912	
7-24-51	N	Qd	1,905	
.....	T	...	1,903	See log.
.....	N	Tf	1,909	
7-18-46	D,S	Qd	1,915	Supply reported adequate.
7-19-46	S	Qd	1,912	..Do....
7-19-46	D,S	Qd	1,884	..Do....
7-19-46	S	Qd	1,887	..Do....
7-23-46	D,S	Qd	1,881	..Do....
7-23-46	S	Qd	1,880	Supply reported inadequate; see chemical analysis.
7-19-46	S	Qd	1,898	Supply reported adequate.
7-19-46	D,S	Qd	1,892	..Do....
7-19-46	D,S	Qd	1,898	..Do....



TABLE 3.--Records

Location No.	Owner or name	Depth of well (feet)	Diameter or size (inches)	Type	Date completed	Depth to water below land surface (feet)
<u>163-89(Cont.)</u>						
27cbc	Vacant	...	12	Dr	.....	11.45
27dad	Leroy Luke	132	2	Dr	.....	100
28bcc1	Robert W. Swenson	186	4	Dr	.....	135.28
28bcc2	..do....	25	2½	Du	.....	16.67
29aaa	U.S. Bureau of Reclamation	15	1¼	Dr	.....	7.10
29acc	..do....	24	1½	Dr	.....	6.91
29add	Test hole 328	170	5	Dr	9- 8-50	.....
29ccc	U.S. Bureau of Reclamation	16	1½	Dr	.....	7.82
31acc	..do....	22.50	1½	Dr	.....	5.25
31ada	Mrs. R. Adenz	10	...	Du	.....	6.40
31ccc	Martha Stahl	200	6	Dr	.....	35
32bdc	C. Hermanson	9	36	Du	.....	2.32
32cbc	Frank Nelson	20	52	Du	.....	14.95
32dcd	Jens Larson	...	...	Du	.....	7.24
33ccc	Unknown	...	48	Du	.....	40.15
33deb	Benny Hass	200	2	Dr	.....	50
34cad1	Fritz Peterson	200	3	Dr	.....	90
34cad2	..do....	187	2	Dr	.....	86.94
35cdc	Unknown	380	2	Dr	.....	.....
<u>163-90</u>						
10bbb	W. S. Town	240	2	Dr	.....	80
12daa	Ted Harms	180	2	Dr	.....	80
13add	Federal Land Bank	300	2	Dr	.....	150
14bbb	Leo Vic	...	48	Du	.....	15.14
14dad	John Jordonson	30	36	Du	.....	25.27
15cc	Missouri-Souris test hole	230	5	Dr	7 -47	3.75
22bcc	Amos Nelson	207	6	Dr	.....	110
22ccc	Unknown	...	18	Dr	.....	28.01
22dcd	Alfred Larson	210	4	Dr	.....	90
24bcc	G. Ganskop	175	2½	Dr	.....	50
24cbc	Christen H. Rawn	412	3	Dr	.....	85
25cbc	Unknown	...	2	Dr	.....	85
25dbd	Vacant	13	36	Du	.....	7.88
26ddd	Henry Rawn	198	6	Dr	.....	77.71

of wells and test holes -- Continued

Date of measurement	Use of water	Geologic source	Altitude of land surface (feet)	Remarks
7-19-46	N	...	1,908	
7-19-46	D,S	Qd	1,920	
7-18-46	S	Qd	1,914	Supply reported inadequate.
7-18-46	N	Qd	1,915	
7-24-51	N	Qd	1,912	
7-24-51	N	Qd	1,906	
.....	T	...	1,925	See log.
7-24-51	N	Qd	1,917	
7-24-51	N	Qd	1,924	
10-22-46	D,S	Qd	1,911	Supply reported adequate.
9-16-45	S	...	1,934	..Do....
7-17-46	N	...	1,909	
7-17-46	D	Qd	1,917	..Do....
7-17-46	D,S	Qd	1,911	..Do....
7-23-46	S	Qd	1,916	
7-23-46	D,S	Qd	1,922	..Do....
7-23-46	D,S	Qd	1,913	..Do....
7-23-46	N	...	1,914	
.....	N	Tf	1,914	
6-27-46	S	Tf	1,921	..Do....
7-17-46	S	...	1,905	..Do....
7-17-46	D,S	Tf	1,916	..Do....
7-16-46	D,S	Qd	1,924	..Do....
7-16-46	S	Qd	1,926	Supply reported inadequate.
7- 9-47	T	...	1,926	See log.
6-27-46	S	Qd	1,935	Supply reported adequate.
8-15-51	D,S	...	1,935	Supply reported moderate.
6-28-46	S	Qd	1,935	Supply reported adequate.
9-21-45	D,S	Qd	1,923	Supply reported adequate for 50 cows.
7-16-46	D,S	Tf	1,933	Supply reported adequate.
7-17-46	D,S	...	1,927	..Do....
7-18-46	N	...	1,926	
7-16-46	D,S	Qd	1,932	..Do....

TABLE 3.--Records

a

Location No.	Owner or name	Depth of well (feet)	Diameter or size (inches)	Type	Date completed	Depth to water below land surface (feet)
<u>163-90(Cont.)</u>						
27ccc	Unknown	...	4.8	Du	.....	25.99
3 <sup>1</sup> aaa	Harlad Knight	48	4	Dr	.....	42.81
34bcc	F. A. Anderson	298	3	Dr	.....	83.27
34cbb	Auge Christenson	275	2	Dr	.....	125
35dcc	W. Huff	22	4.8	Du	.....	12.60
36cb	Missouri-Souris test hole	235	4 3/4	Dr	7 -47	20.50
<u>164-88</u>						
31bad	Unknown	...	4	Dr	.....	62.86
31ddd	Ottis Nolting	100	4	Dr	.....	.....
32bc	T. W. Ryan	156	4	Dr	.....	66.24
<u>164-89</u>						
30add	U.S. Customs House	135	4 1/2	Dr	1953	60
30dd2	Carl Wolen	22	...	Du	.....	18
3lacc	H. McGilluary	156	2	Dr	.....	79.00
3lad	Unknown	165	2	Dr	.....	.....
3lbdc	..do....	...	..	Du	.....	12.27
32ada	Vacant	175	2	Dr	.....	.....
32bbc	Ed McIntel	140	...	Dr	.....	80
32beb	Great Northern Railroad	186	8	Dr	.....	55
32ddd	Unknown	90	2	Dr	.....	25
33bc	Henry Irving	200	3	Dr	.....	2.30
34cdb	Carl Heile	150	2	Dr	.....	40
36ddd	Vacant	13	84	Du	.....	10.80
<u>164-90</u>						
25dc1	P. Tafelmeyer	150	4	Dr	.....	90
25dc2	..do....	20	30	Du	.....	11.77
26dc	Herman Ganskop	170	4	Dr	.....	110
3 <sup>1</sup> cc1	F. Wolkenhauer	200	6	Dr	.....	95.02
3 <sup>1</sup> cc2	..do....	10	26	Du	.....	6.84
35dc	H. G. Holtz	160	2	Dr	.....	.....

of wells and test holes -- Continued

Date of measurement	Use of water	Geologic source	Altitude of land surface (feet)	Remarks
6-27-46	N	Qd	1,932	
6-28-46	S	...	1,932	Pumps dry.
6-28-46	S	Tf	1,944	Supply reported adequate.
6-28-46	D,S	Tf	1,934	..Do....
10- 9-50	D,S	Qd	1,918	..Do....
7-10-47	T	...	1,913	See log.
7-25-46	S	...	1,853	
.....	N	...	1,855	
7-25-46	S	...	1,853	
.....	D	Tf	1,843	Supply reported adequate.
.....	D	Qd	1,843	Supply reported small.
7-17-46	D,S	...	1,872	Supply reported adequate.
.....	D	Qd	1,867	
7-17-46	N	Qd	1,872	
.....	N	...	1,842	
.....	D,S	...	1,847	Supply reported inadequate.
11- 9-50	S	Qd	1,859	Supply reported adequate.
7-18-46	S	Qd	1,856	
9-24-?	N	...	1,841	
7-19-46	D,S	Qd	1,941	
9-24-45	N	Qd	1,850	
.....	S	Qd	1,865	
7-16-46	D	Qd	1,866	..Do....
7-17-46	D,S	Qd	1,873	..Do....
6-27-46	S	Qd	1,896	..Do....
6-27-46	D	Qd	1,893	..Do....
.....	N	...	1,892	

TABLE 4.--Logs of test holes

161-88-5aba  
 Test hole 541  
 Ward County

<u>Formation</u>	<u>Material</u>	<u>Thickness</u> (feet)	<u>Depth</u> (feet)
Glacial drift:			
	Clay, sandy, yellowish-gray.....	27	27
	Clay, sandy, medium-gray (till).....	3	30
	Clay, sandy, gravelly, gray (till)....	5	35
	Clay, sandy, medium-gray (till).....	5	40
	Clay, sandy and gravelly, gray (till).	10	50
	Clay, gravelly, medium-gray (till)....	43	93
Fort Union Formation:			
	Clay, sandy, very light-gray.....	17	110

161-88-5bbb  
 Test hole 539  
 Ward County

Glacial drift:			
	Topsoil, dark-brown.....	2	2
	Clay, gravelly, yellowish-gray (till).	44	46
	Sand, coarse.....	5	51
	Clay, bouldery, medium-gray (till)....	32	83
	Gravel and boulders.....	3	86
	Clay, sandy, yellow (till).....	14	100
	Clay, gravelly, gray (till).....	16	116
	Sand, very coarse, and gravel.....	27	143
	Clay, bouldery, gray (till).....	157	300
Fort Union Formation:			
	Clay, smooth, light-gray.....	10	310
	Clay, sandy, gray with lignite fragments (Samples very poor and indistinctive from 300 to 340 feet)	30	340

TABLE 4.--Logs of test holes -- Continued

161-88-5bab  
 Test hole 540  
 Ward County

<u>Formation</u>	<u>Material</u>	<u>Thickness</u> (feet)	<u>Depth</u> (feet)
Glacial drift:			
	Clay, bouldery, yellowish-gray (till).	8	8
	Clay, gravelly, yellowish-gray (till).	16	24
	Clay, gravelly, medium-gray (till)....	56	80
	Clay, yellowish-gray. Many boulders between 90 and 110 feet (till).....	117	197
	Gravel and boulders.....	18	215
Fort Union Formation:			
	Shale, light-gray.....	7	222
	Lignite.....	2	224
	Shale, medium-gray.....	26	250

161-89-4aaa1  
 Test hole 10  
 Burke County

Galcial drift:			
	Topsoil, dark-brown, clay, sandy.....	2	2
	Clay, grayish-tan (till).....	9	11
	Sand, coarse, clayey.....	7	18
Fort Union Formation:			
	Clay, light-gray.....	4	22

161-89-4aaa2  
 Test hole 535  
 Burke County

Glacial drift:			
	Clay, gravelly, yellowish-gray (till).	4	4
	Clay, gravelly, yellowish-gray (till).	38	42
	Clay, gravelly, light-gray (till).....	11	53
Fort Union Formation:			
	Clay, light-gray.....	7	60

TABLE 4.--Logs of test holes -- Continued

161-89-4ccc  
 Test hole 531  
 Burke County

<u>Formation</u>	<u>Material</u>	<u>Thickness</u> (feet)	<u>Depth</u> (feet)
Glacial drift:			
	Clay, sandy, gravelly, yellowish-gray (till).....	21	21
	Sand.....	2	23
	Clay, gravelly, yellowish-brown (till)	9	32
	Clay, bouldery, medium-gray (till)....	7	39
Fort Union Formation:			
	Clay, gray.....	9	48
	Lignite.....	2	50

TABLE 4.--Logs of test holes -- Continued

161-89-5aad  
 Test hole 548  
 Burke County

<u>Formation</u>	<u>Material</u>	<u>Thickness</u> (feet)	<u>Depth</u> (feet)
Glacial drift:			
	Topsoil.....	1	1
	Clay, light-brown, pebbly, highly calcareous (till).....	19	20
	Clay, same as above but containing much very coarse sand.(till).....	14	34
	Clay, sandy, gray; sand, coarse (till)	26	60
	Clay, pebbly, dark-gray (till).....	12	72
Fort Union Formation:			
	Clay, sandy, light-gray.....	8	80
	Lignite.....	5	85
	Clay, gray.....	8	93
	Lignite.....	4	97
	Clay, gray.....	2	99
	Lignite.....	3	102
	Clay, sandy, light-gray.....	32	142
	Lignite.....	4	146
	Clay, light-gray.....	47	193
	Siltstone, gray.....	4	197
	Clay, light-gray.....	20	217
	Core 210-220 ft.; 6½ ft. recovery. Silt and very fine sand, light-tan, micaceous (1.2 ft) Clay, light-gray to medium-gray intercalated with thin seams of lignite (5.3 ft.)		
	Lignite.....	2	219
	Clay, light-gray.....	1	220
	Sand, very fine, clayey.....	12	232
	Core 220-230 ft., 2 ft. recovery. Clay light-gray with thin seams of very fine sand which contain fossil fish scales and gastropods.		
	Core 230-240 ft., 5 ft. recovery. Clay light-olive gray, very dense and uniform.		
	Clay, light-olive gray and light-tan..	15	247
	Lignite.....	2	249
	Clay, light-gray.....	35	284



TABLE 4.--Logs of test holes -- Continued

161-89-5aad (Continued)  
 Test hole 548  
 Burke County

<u>Formation</u>	<u>Material</u>	<u>Thickness</u> (feet)	<u>Depth</u> (feet)
	Lignite.....	1	285
	Clay, light-gray.....	1	286
	Siltstone and shale, poor sample.....	5	291
	Clay, light-gray.....	11	302
	Shale, hard, brown.....	2	304
	Clay, very light-gray.....	56	360
	Sand, very fine, with clay, sandy, gray.....	16	376
	Clay, very light-gray.....	5	381
	Sand, very fine, with clay, sandy, gray	13	394
	Clay, light-gray.....	2	396
	Lignite.....	3	399
	Clay, light-gray.....	3	402
	Lignite.....	5	407
	Clay, brown.....	5	412
	Lignite.....	6	418
	Clay, light yellowish-gray.....	12	430
	Clay, light-gray.....	14	444
	Lignite.....	1	445
	Clay, medium-gray.....	31	476
	Clay, brown, with thin seams of lignite	6	482
	Clay, sandy, gray.....	15	497
	Clay, brown.....	7	504
	Clay, light-gray.....	24	528
	Clay, very sandy, light-gray.....	5	533
	Clay, light-gray.....	5	538
	Sand, medium to coarse, ("salt and pepper").....	15	553
	Clay, medium-gray.....	47	600

TABLE 4.--Logs of test holes -- Continued

161-89-5bbb  
 Test hole 546  
 Burke County

<u>Formation</u>	<u>Material</u>	<u>Thickness</u> (feet)	<u>Depth</u> (feet)
Glacial drift:			
	Topsoil, dark-brown.....	1	1
	Clay, gravelly, yellowish-gray (till).	22	23
	Clay, gravelly, light-gray, and coal fragments (till).....	10	33
Fort Union Formation:			
	Shale, light-gray.....	7	40

161-89-5bcc  
 Test hole 5  
 Burke County

Glacial drift:			
	Soil, silty, brown.....	2	2
	Clay, pebbly, tan (till).....	10	12
	Clay, gravelly, yellow (till).....	5	17
Fort Union Formation:			
	Clay, gray.....	1	18
	Lignite.....	3	21

161-89-5cad1  
 Test hole 8  
 Burke County

Glacial drift:			
	Topsoil, sandy, black.....	1	1
	Clay, sandy, tan (till).....	2	3
	Clay, sandy, gray (till).....	2	5
Fort Union Formation:			
	Lignite.....	$\frac{1}{2}$	$5\frac{1}{2}$
	Lignite, black, and interbedded light- gray clay.....	$8\frac{1}{2}$	14
	Sand, very fine, light-gray, clay.....	3	17

TABLE 4.--Logs of test holes -- Continued

161-89-5aad2  
 Test hole 9  
 Burke County

<u>Formation</u>	<u>Material</u>	<u>Thickness</u> (feet)	<u>Depth</u> (feet)
Glacial drift:			
	Topsoil, sandy, black.....	1	1
	Clay, sandy, pebbly, tan (till).....	15	16
Fort Union Formation:			
	Lignite.....	1	17

161-89-5cb  
 Missouri-Souris test hole\*

Glacial drift:			
	Soil.....	2	2
	Clay, sandy, yellow.....	8	10
	Gravel and fine sand.....	7	17
	Clay, sandy, gray.....	5	22
Fort Union Formation:			
	Clay, sandy, gray, with some gravel...	5	27
	Lignite.....	4	31
	Clay, sandy, gray.....	14	45
	Lignite.....	2	47
	Clay, sandy, gray.....	6	53
	Lignite.....	3	56
	Sand, gray, and clay.....	9	65

Ho!e filled

\*Log obtained from LaRocque and others  
 (open-file report).

TABLE 4.--Logs of test holes -- Continued

		161-89-5cbc1 Test hole 1 Burke County	
<u>Formation</u>	<u>Material</u>	<u>Thickness</u> (feet)	<u>Depth</u> (feet)
Glacial drift:			
	Topsoil, sandy, dark-brown.....	1	1
	Clay, pebbly, tan (till).....	20	21
Fort Union Formation:			
	Clay, silty, gray.....	17	38
	Lignite.....	1	39
	Clay, light-gray; a little gypsum.....	13	52
	Sand, very fine, silty, light-gray....	10	62
	Clay, light-gray; lignite.....	5	67
		161-89-5cbc2 Test hole 2 Burke County	
Glacial drift:			
	Topsoil, sandy, black.....	2	2
	Clay, yellowish-tan, pebbly (till)....	12	14
	Clay, pebbly, gray (till).....	2	16
Fort Union Formation:			
	Lignite.....	1	17
	Clay, silty, light-gray.....	4	21
		161-89-5cdal Test hole 6 Burke County	
Glacial drift:			
	Topsoil, sandy, brown.....	2	2
	Clay, sandy, tan (till).....	1	3
	Sand, medium.....	2	5
	Clay, sandy, pebbly, tan (till).....	6	11
Fort Union Formation:			
	Lignite, black; and interbedded gray sandy clay.....	6	17

TABLE 4.--Logs of test holes -- Continued

161-89-5cda2  
 Test hole 7  
 Burke County

<u>Formation</u>	<u>Material</u>	<u>Thickness</u> (feet)	<u>Depth</u> (feet)
Glacial drift:			
	Topsoil, sandy, black.....	2	2
	Clay, sandy, pebbly, tan (till).....	3	5
	Clay, sandy, pebbly, gray (till).....	4	9
Fort Union Formation:			
	Lignite.....	4	13
	Clay, light-gray.....	4	17

161-89-5dab  
 Test hole 331  
 Burke County

Glacial drift:			
	Topsoil, black.....	1	1
	Clay, sandy, gravelly, light-buff (till).....	23	24
Fort Union Formation:			
	Clay, sandy, light-gray.....	10	34
	Lignite.....	5	39
	Clay, light-gray.....	21	60
	Clay, light-gray, sand.....	15	75
	Sand, fine, clayey, light-gray.....	9	84
	Lignite.....	3	87
	Clay, sandy, light-gray.....	7	94
	Lignite.....	2	96
	Clay, carbonaceous, smooth, dark-brown	1	97
	Clay, sandy, light-gray.....	3	100

TABLE 4.--Logs of test holes -- Continued

161-89-6daa1  
 Test hole 3  
 Burke County

<u>Formation</u>	<u>Material</u>	<u>Thickness</u> (feet)	<u>Depth</u> (feet)
Glacial drift:			
	Topsoil, sandy, black.....	$\frac{1}{2}$	$\frac{1}{2}$
	Clay, sandy, yellow (till).....	$3\frac{1}{2}$	4
	Sand and gravel.....	1	5
	Clay, sandy, yellow (till).....	2	7
	Sand and gravel.....	3	10
Fort Union Formation:			
	Lignite.....	$\frac{1}{2}$	$10\frac{1}{2}$
	Clay, silty, gray.....	$6\frac{1}{2}$	17

161-89-6daa2  
 Test hole 4  
 Burke County

Glacial drift:			
	Topsoil, sandy, black.....	1	1
	Clay, silty, gray (till).....	2	3
	Clay, silty, tan (till).....	1	4
	Sand, coarse, clayey.....	2	6
Fort Union Formation:			
	Lignite.....	$2\frac{1}{2}$	$8\frac{1}{2}$
	Clay, gray.....	$3\frac{1}{2}$	12

TABLE 4.--Logs of test holes -- Continued

161-89-9bcc  
 Test hole 530  
 Burke County

<u>Formation</u>	<u>Material</u>	<u>Thickness</u> (feet)	<u>Depth</u> (feet)
Glacial drift:			
	Soil, dark-brown.....	1	1
	Clay, sandy, yellowish-gray (till)....	18	19
	Clay, gravelly, light-olive gray (till).....	7	26
	Sand.....	2	28
	Clay, bouldery, medium-gray (till)....	64	92
	Clay, sandy, dark-yellowish-orange. Many limonitic shale pebbles (till).	3	95
Fort Union Formation:			
	Lignite.....	3	98
	Clay, light-gray.....	17	115

161-89-11daa  
 Test hole 542  
 Burke County

Glacial drift:			
	Clay, very bouldery, yellowish-gray (till).....	34	34
	Clay, very bouldery, light-gray (till)	43	77
	Clay, sandy, yellowish-gray (till)....	13	90
	Clay, light to medium gray (till).....	120	210
	Clay, hard, light-olive gray (till)...	40	250
	Clay, gravelly, yellowish-gray (till).	5	255
Fort Union(?) Formation:			
	Clay, sandy, light-gray. Samples consist of cavings.....	72	327

TABLE 4.--Logs of test holes -- Continued

161-89-14ddd  
 Test hole 543  
 Burke County

<u>Formation</u>	<u>Material</u>	<u>Thickness</u> (feet)	<u>Depth</u> (feet)
Glacial drift:			
	Topsoil, dark-brown.....	1	1
	Clay, gravelly, yellowish-gray (till).	39	40
	Clay, sandy, light-gray (till).....	90	130
Fort Union Formation:			
	Lignite.....	4	134
	Clay, shaley, light-gray.....	6	140

161-89-16bbb  
 Test hole 529  
 Burke County

Glacial drift:			
	Topsoil, black.....	1	1
	Clay, sandy, light grayish-tan (till).	17	18
	Clay, sandy and gravelly, gray (till).	42	60
	Clay, sandy, yellowish-brown (till)...	10	70
	Clay, gravelly, yellowish-brown and gray (till).....	30	100
	Clay, sandy, gravelly, gray (till)....	30	130
	Clay, sandy, medium-gray (till).....	132	262
	Sand, very coarse.....	2	264
	Clay, gravelly, light-gray (till).....	20	284
Fort Union Formation:			
	Lignite.....	2	286
	Clay, shbley, light-gray.....	9	295



TABLE 4.--Logs of test holes -- Continued

161-89-16bcb  
 Test hole 545  
 Burke County

<u>Formation</u>	<u>Material</u>	<u>Thickness</u> (feet)	<u>Depth</u> (feet)
Glacial drift:			
	Topsoil, dark-brown.....	2	2
	Clay, yellowish-gray.....	4	6
	Clay, sandy, yellowish-gray (till)....	17	23
	Sand, fine, clayey.....	7	30
	Sand, fine to medium.....	5	35
	Sand and gravel, possibly some clay...	2	37
	Clay, gravelly, medium-gray (till)....	25	62
	Gravel, fine granular, hard drilling..	4	66
	Clay, gravelly, medium-gray (till)....	15	81
	Sand and gravel.....	9	90
	Granule gravel.....	6	96
	Clay, gravelly, gray (till).....	5	101
	Sand, fine to coarse with some gravel.	4	105
	Gravel, granular, pebbly.....	5	110
	Clay, sandy, light-gray (till).....	70	180

161-89-16bcc  
 Test hole 532  
 Burke County

Glacial drift:			
	Clay, gravelly, yellowish-gray (till).	22	22
	Sand, fine to coarse.....	8	30
	Clay, gravelly, medium-gray (till)....	22	52
	Sand, medium and coarse, gravelly.....	3	55
	Clay, gravelly, medium-gray (till)....	11	66
	Sand, clayey, boulders.....	6	72
	Clay, bouldery, medium-gray (till)....	61	133
	Sand, clayey.....	4	137
	Clay, sandy, gray (till).....	4	141
	Sand and gravel (reported by drillers), samples show mostly clay.....	26	167
Fort Union Formation:			
	Clay, light-gray (samples probably not very representative).....	71	238
	Lignite.....	2	240
	Clay, light-gray.....	6	300

TABLE 4.--Logs of test holes -- Continued

161-89-16cbc  
 Test hole 544  
 Burke County

<u>Formation</u>	<u>Material</u>	<u>Thickness</u> (feet)	<u>Depth</u> (feet)
Glacial drift:			
	Topsoil, dark-brown.....	1	1
	Clay, sandy, yellowish-gray (till)....	3	4
	Clay, gravelly, yellowish-gray (till).	31	35
	Clay, bouldery, light-gray (till).....	57	92
	Gravel, fine to medium, clayey.....	15	107
Fort Union Formation:			
	Clay, very sandy, very light-gray.....	13	120

161-89-16ccc  
 Test hole 533  
 Burke County

Glacial drift:			
	Soil, dark-brown.....	1	1
	Clay, gravelly, yellowish-gray (till).	31	32
	Clay, gravelly, light-gray (till).....	49	81
Fort Union Formation:			
	Clay, sandy, light-gray.....	12	93
	Lignite.....	7	100

161-89-20add  
 Test hole 534  
 Burke County

Glacial drift:			
	Topsoil, dark-brown.....	2	2
	Clay, sandy, yellowish-gray (till)....	24	26
	Clay, sandy, light-gray (till).....	36	62
	Clay, gravelly, grayish-yellow (till).	8	70
Fort Union Formation:			
	Clay, light-gray.....	10	80

TABLE 4.--Logs of test holes -- Continued

161-89-36dd  
Missouri-Souris test hole\*

<u>Formation</u>	<u>Material</u>	<u>Thickness</u> (feet)	<u>Depth</u> (feet)
Glacial drift:			
	Soil, sand, brown.....	1	1
	Clay, sandy, brown, with some gravel.	14	15
	Clay, sandy, gray, with some gravel..	33	48
	Clay, sandy, gray, with strips of limestone.....	4	52
	Boulder, granite.....	1	53
	Clay, sandy, gray with boulders and small strips of limestone.....	12	65
	Clay, sandy, gray; with some gravel..	17	82
	Clay, sandy, gray, with strips of brown sandy clay, with some gravel and lignite.....	13	95
	Boulder, granite.....	1	96
	Clay, sandy, gray with some gravel and lignite fragments.....	44	140
	Clay, sandy, gray, with small strips of gravel.....	6	146
	Clay, sandy, gray, with small strips of lignite and gravel.....	19	165
	Lignite, hard, with small strips of gravel.....	5	170
	Lignite, hard.....	9	179
	Lignite, hard, with small strips of gravel.....	30	209
	Lignite, hard, with strips of gravel and gray sandy clay.....	15	224
	Clay, sandy, gray, small strips of lignite.....	34	258
	Boulders and gravel, small strips of lignite.....	32	290
	Boulders and gravel.....	20	310
Fort Union Formation:			
	Lignite and some gravel (wash-down)..	4	314
	Clay, sandy, gray.....	1	315

Hole filled

\*Log obtained from LaRocque and others  
(open-file report)

TABLE 4.--Logs of test holes -- Continued

162-88-31cdc  
 Test hole 538  
 Burke County

<u>Formation</u>	<u>Material</u>	<u>Thickness</u> (feet)	<u>Depth</u> (feet)
Glacial drift:			
	Topsoil, dark-brown.....	1	1
	Clay, sandy, yellow to gray.....	2	3
	Clay, sandy, yellowish-gray (till)....	7	10
	Sand, medium to coarse, clean.....	12	22
	Clay, gravelly, medium-gray (till)....	62	84
	Clay, very sandy, yellowish-gray (till)	11	95
	Clay, bouldery, light-gray (till).....	38	133
	Gravel, granular.....	3	136
	Clay, gravelly, gray (till).....	22	158
	Gravel and boulders.....	25	183
	Clay, sandy, bouldery, yellowish-gray (till).....	22	205
	Clay, gravelly, medium-gray (till).....	95	300
Fort Union Formation:			
	Clay, shaley, light-gray. Poor samples.	3	303

162-89-4bbb  
 Test hole 327  
 Burke County

Glacial drift:			
	Topsoil, sandy, black.....	1	1
	Clay, very sand and gravelly, tan (till).....	11	12
	Sand, fine to very coarse, and some fine gravel.....	7	19
	Clay, sandy, pebbly, tan (till).....	17	36
	Clay, sandy, pebbly, gray (till).....	84	120
	Clay, sandy, hard, gray. Numerous boulders (till).....	95	215
	Clay, sandy, hard, gray; cavings predominant in samples (till).....	69	284

TABLE 4.--Logs of test holes -- Continued

162-89-8aaa  
 Test hole 326  
 Burke County

<u>Formation</u>	<u>Material</u>	<u>Thickness</u> (feet)	<u>Depth</u> (feet)
Glacial drift:			
	Topsoil, sandy, black.....	1	1
	Clay, yellow, sandy.....	3	4
	Clay, sandy, gravelly, tan (till)....	10	14
	Clay, sandy, pebbly, bouldery (till)..	24	38
	Gravel, medium to coarse.....	12	50
	Clay, sandy, boulders, gray (till)....	171	221
	Sand, medium and coarse, clayey, gray.	11	232
	Clay, sandy, gray, with lignite fragments (till).....	22	254
	Clay, smooth, grayish-brown (till)....	11	265
	Clay, sandy, gray, lignite fragments (till).....	72	337
	Clay, sandy, yellowish-brown (till)...	8	345
	Clay, sandy, gray, sand and gravel, cavings in samples (till).....	65	410
Fort Union Formation:			
	Clay, gray.....	5	415
	Clay, shaley, black.....	5	420
	Clay, smooth, gray.....	10	430

TABLE 4.--Logs of test holes -- Continued

162-89-13cc  
Missouri-Souris test hole\*

<u>Formation</u>	<u>Material</u>	<u>Thickness</u> (feet)	<u>Depth</u> (feet)
Glacial drift:			
	Soil.....	1	1
	Clay, sandy, yellow.....	5	5
	Clay, sandy, yellow, with some gravel.	11	16
	Clay, sandy, gray with some gravel....	5	21
	Sand, fine, and gravel.....	2	23
	Clay, sandy, gray with some gravel....	15	38
	Gravel.....	2	40
	Clay, sandy, gray, with some boulders.	3	43
	Boulder.....	1	44
	Clay, sand, gray, with some gravel and boulders.....	4	48
	Clay, sandy, gray, with some gravel and lignite fragments.....	44	92
	Sand, fine.....	1	93
	Clay, sandy, gray, with some gravel and lignite fragments.....	3	96
	Boulder, granite.....	2	98
	Clay, sandy, gray with some gravel....	7	105
	Clay, sandy, gray, with some gravel and lignite fragments.....	40	145
	Gravel.....	1	146
	Clay, sandy, gray, with small strips of gravel and lignite fragments.....	16	162
	Gravel and lignite fragments with strips of gray sandy clay.....	6	168
	Clay, sandy, gray, with small strips of gravel and lignite fragments.....	17	185
Fort Union Formation:			
	Lignite.....	3	188
	Lignite, with strips of white clay....	30	218
	Clay, white, with strips of lignite...	20	238
	Limestone, gray.....	3	241
	Sand, gray.....	9	250

Hole filled

\*Log obtained from LaRocque and others  
(open-file report)

TABLE 4.--Logs of test holes -- Continued

162-89-16bbc  
 Test hole 325  
 Burke County

<u>Formation</u>	<u>Material</u>	<u>Thickness</u> (feet)	<u>Depth</u> (feet)
Glacial drift:			
	Topsoil, sandy, black.....	1	1
	Clay, sandy, light-gray.....	2	3
	Sand, fine to medium.....	1	4
	Clay, yellow, with interbedded sand and gravel (till).....	6	10
	Clay, sandy, pebbly, tan (till).....	8	18
	Clay, sandy, pebbly, dark-gray (till)	26	44
	Clay, pebbly, yellow (till).....	1	45
	Clay, pebbly, dark-gray (till).....	45	90
	Clay, sandy, and very gravelly, dark- gray (till).....	90	180
	Clay, sandy, tan (till).....	12	192
	Clay, very sandy, tan and gray. A lot of coarse sand and gravel (till)...	17	209
Fort Union Formation:			
	Clay, smooth, light-green.....	9	218

162-89-21bbb  
 Test hole 324  
 Burke County

Glacial drift:			
	Topsoil, sandy, black.....	1	1
	Clay, sandy, pebbly, tan (till).....	17	18
	Clay, sandy, pebbly, brown (till)....	12	30
	Clay, sandy, pebbly, gray (till).....	128	158
Fort Union Formation:			
	Clay, sandy, gray.....	12	170

TABLE 4.--Logs of test holes -- Continued

162-89-28dd  
Missouri-Souris test hole\*

<u>Formation</u>	<u>Material</u>	<u>Thickness</u> (feet)	<u>Depth</u> (feet)
Glacial drift:			
	Soil.....	3	3
	Clay, yellow.....	10	13
	Clay, sandy, gray with some gravel...	38	51
	Sand, fine and gravel.....	4	55
	Clay, sandy, gray, with some gravel..	11	66
	Clay, sandy, gray, with some strips of limestone.....	6	72
	Clay, sandy, gray, with some gravel..	28	100
	Limestone and "sand" rock.....	1	101
	Clay, sandy, gray, with some gravel and lignite fragments.....	14	115
Fort Union Formation:			
	Clay, gray.....	5	120
	Lignite.....	2	122
	Clay, light-gray.....	23	145

Hole filled

\*Log obtained from LaRocque and others  
(open-file report)



TABLE 4.--Logs of test holes -- Continued

162-89-29aaa  
 Test hole 323  
 Burke County

<u>Formation</u>	<u>Material</u>	<u>Thickness</u> (feet)	<u>Depth</u> (feet)
Glacial drift:			
	Topsoil, sandy, black.....	1	1
	Clay, pebbly, tan (till).....	23	24
	Clay, gravelly, tan (till).....	16	40
	Clay, sandy, tan (till).....	6	46
	Sand, cemented, tan.....	5	51
	Clay, sandy, gravelly, tan (till)....	2	53
	Clay, sandy, pebbly, bluish-gray (till)	51	104
	Sand, fine silty, clayey, light-gray.	13	117
	Clay, sandy, pebbly, bluish-gray (till)	50	167
	Gravel and rock fragments, predominant- ly dolomitic.....	4	171
	Gravel, fine, mixed with clay.....	4	175
	Clay, sandy, pebbly, bluish-gray (till).....	33	208
Fort Union Formation:			
	Lignite.....	1	209
	Clay, sandy, gray.....	7	216
	Clay, sandy, brown.....	4	220
	Clay, sandy, gray.....	10	230

162-89-33bbb  
 Test hole 322  
 Burke County

Glacial drift:			
	Topsoil, sandy, brown.....	1	1
	Clay, gravelly, tan.....	2	3
	Sand, fine.....	1	4
	Clay, sandy, pebbly, tan (till).....	26	30
	Clay, sandy, bouldery, gray (till)...	16	46
Fort Union Formation:			
	Lignite.....	2	48
	Clay, gray.....	30	78
	Clay, very sandy, light-gray.....	2	80

TABLE 4.--Logs of test holes -- Continued

162-89-35cco  
 Test hole 536  
 Burke County

<u>Formation</u>	<u>Material</u>	<u>Thickness</u> (feet)	<u>Depth</u> (feet)
Glacial drift:			
	Clay, sandy, yellowish-gray (till)...	17	17
	Clay, bouldery, medium-gray (till)...	64	81
Fort Union Formation:			
	Clay, shaley, sandy, light-gray.....	5	86
	Lignite.....	4	90

162-89-35ddd  
 Test hole 537  
 Burke County

Glacial drift:			
	Clay, sandy, yellowish-gray (till)...	34	34
	Clay, sandy, bouldery, medium-gray (till).....	66	100
	Gravel.....	4	104
	Clay, bouldery, medium-gray (till)...	12	116
Fort Union Formation:			
	Clay, shaley, light-gray.....	4	120

162-90-10cbc  
 U. S. Bureau of Reclamation test hole\*

Glacial drift:			
	Soil, silty, brown.....	1.7	1.7
	Clay, silty, olive-brown with salt pockets.....	13.3	15.0
	Sand, clayey, stratified, olive-brown	1.0	16.0
	Clay, silty, olive-brown.....	6.5	22.5

\*Log obtained from LaRocque and others  
 (open-file report)

TABLE 4.--Logs of test holes -- Continued

162-90-34ddd1  
 Test hole 547  
 Burke County

<u>Formation</u>	<u>Material</u>	<u>Thickness</u> (feet)	<u>Depth</u> (feet)
Glacial drift:			
	Topsoil, dark-brown.....	1	1
	Clay, gravelly, yellowish-gray (till)	10	11
Fort Union Formation:			
	Clay, light-gray.....	1	12
	Lignite.....	6	18
	Clay, light-gray.....	2	20

163-89-17da  
 Missouri-Souris test hole\*

Glacial drift:			
	Sand, brown, and boulders.....	10	10
	Clay, sandy, brown.....	16	26
	Sandstone.....	1	27
	Clay, sandy, brown, with strips of limestone.....	3	30
	Clay, sandy, gray.....	17	47
	Clay, sandy, brown.....	1	48
	Clay, sandy, gray, with lignite fragments	60	108
	Clay, sandy, gray, with some gravel and lignite.....	51	159
	Sand, fine, and gravel with boulders and lignite fragments.....	30	189
	Boulder.....	2	191
	Sand, fine, and gravel with boulders and lignite fragments.....	9	200
	Boulders, with gravel and fine sand..	3	203
	Gravel, with lignite fragments.....	8	211
	Gravel, fine sand with boulders, strips of clay and lignite fragments.....	71	282
Fort Union Formation:			
	Sand, fine, gray.....	18	300

Hole filled

\*Log obtained from LaRocque and others  
 (open-file report)

TABLE 4.--Logs of test holes -- Continued

163-89-21bbb  
 Test hole 329  
 Burke County

<u>Formation</u>	<u>Material</u>	<u>Thickness</u> (feet)	<u>Depth</u> (feet)
Glacial drift:			
	Topsoil, sandy, black.....	1	1
	Clay, sandy, light-brown and gray...	2	3
	Clay, sandy, pebbly, tan (till).....	17	20
	Sand, coarse, clayey.....	6	26
	Clay, sandy, bouldery, tan (till)....	16	42
	Clay, gray with sand, gravel and numerous boulders (till).....	175	217
	Clay, yellow and white;sand, gravel, and numerous boulders (till).....	18	235
	Gravel and boulders. Hole abandoned.	5	240

163-89-29add  
 Test hole 328  
 Burke County

Glacial drift:			
	Topsoil, sandy, black.....	1	1
	Clay, sandy, light-tan (till).....	18	19
	Clay, sandy, tan (till).....	11	30
	Sand, fine, medium, and coarse.....	5	35
	Sand, fine to very coarse, clayey....	5	40
	Sand, fine and medium.....	10	50
	Gravel, fine and considerable clay...	5	55
	Clay, very gravelly, dark-gray (till)	15	70
	Clay, gray. Numerous limestone, dolomite and other rock fragments scattered throughout sample (till).	77	147
Fort Union Formation:			
	Clay, light-gray to white.....	8	155
	Clay, light-brown.....	5	160
	Core obtained from 160-170 feet.		
	Clay, dark-gray.....	2	162
	Clay, very light greenish-gray, becoming nearly white in places....	7 $\frac{1}{2}$	169 $\frac{1}{2}$
	Clay, sandy, dark-gray to black.....	$\frac{1}{2}$	170

TABLE 4.--Logs of test holes -- Continued

163-90-15cc  
Missouri-Souris test hole\*

<u>Formation</u>	<u>Material</u>	<u>Thickness</u> (feet)	<u>Depth</u> (feet)
Glacial drift:			
	Soil.....	1	1
	Clay, sandy, yellow, with some gravel	18	19
	Clay, sandy, gray, wth some gravel..	28	47
	Gravel.....	2	49
	Clay, sandy, gray.....	1	50
	Gravel.....	9	59
	Clay, sandy, gray, with some gravel..	31	90
	Clay, sandy, gray, with some gravel and boulders.....	20	110
	Clay, gray, with some gravel, boulders, and lignite fragments.....	62	172
	Boulders, with gravel and lignite fragments.....	50	222
Fort Union Formation:			
	Lignite, hard.....	8	230

Hole filled

\*Log obtained from LaRocque and others  
(open-file report)

TABLE 4.--Logs of test holes -- Continued

163-90-36cb  
Missouri-Souris test hole\*

<u>Formation</u>	<u>Material</u>	<u>Thickness</u> (feet)	<u>Depth</u> (feet)
Glacial drift:			
	Soil.....	3	3
	Clay, yellow.....	6	9
	Clay, brown, with some gravel.....	19	28
	Clay, gray.....	8	36
	Clay, sandy, gray, with some gravel and lignite fragments.....	114	150
	Boulder, limestone.....	1	151
	Clay, sandy, gray, with some gravel and lignite fragments.....	18	169
	Gravel with strips of gray sandy clay	3	172
	Clay, sandy, gray, with lignite fragments.....	8	180
	Gravel and boulders.....	21	201
	Clay, sandy, gray, with some gravel..	5	206
Fort Union Formation:			
	Lignite, hard.....	14	220
	Sand, gray.....	15	235

Hole filled

\*Log obtained from LaRocque and others  
(open-file report)

## REFERENCES

- Abbott, G. A., and Voedisch, F. W., 1938, The municipal ground-water supplies of North Dakota: North Dakota Geol. Survey Bull. 11, 99 p.
- Akin, P. D., 1951, Ground water in the Mohall area, Bottineau and Renville Counties, North Dakota: North Dakota Ground-Water Studies No. 17, 76 p.
- Brown, R. W., and Lemke, R. W., 1948, Newly discovered outcrops of the Cannonball Formation in North Dakota: Science, v. 107, p. 624-625.
- LaRocque, G. A., Swenson, H. A., Greenman, D. W., 1951, Ground water in the Crosby-Mohall area, North Dakota: U.S. Geol. Survey open-file report.
- Lemke, R. W., and Kay, C. A., 1953, Geology of the Bowbells quadrangle, North Dakota: U.S. Geol. Survey Geol. Quad. Map GQ-26.
- Lemke, R. W., 1960, Geology of the Souris River area, North Dakota: U.S. Geol. Survey Prof. Paper 325, 138 p.
- Meinzer, O. E., 1923, The occurrence of ground water in the United States, with a discussion of principles: U.S. Geol. Survey Water-Supply Paper 489, 321 p.
- Robinove, C. J., Langford, R. H., and Brookhart, J. W., 1958, Saline-water resources of North Dakota: U.S. Geol. Survey Water-Supply Paper 1428, 72 p.
- Simpson, H. E., 1927, A report on the water supply for Bowbells, North Dakota: North Dakota Geol. Survey open-file report, 6 p.
- \_\_\_\_\_ 1929, Geology and ground-water resources of North Dakota, with a discussion of the chemical character of the water, by H. B. Riffenburg: U.S. Geol. Survey Water-Supply Paper 598, 312 p.
- Towse, D. F., 1952, Summary of the California Company Thompson No. 1 well, Bottineau County, North Dakota: North Dakota Geol. Survey Circ. 7, 23 p.
- U.S. Public Health Service, 1961, Drinking water standards: Am. Water Works Assoc. Jour., v. 53, no. 8, p. 935-945.
- U.S. Weather Bureau, 1960, Climatological data for North Dakota, annual summary, 1959: v. 68, no. 13, p. 180-189.
- Welsh, G. B., and Thomas, J. F., 1960, Significance of chemical limits in U.S. Public Health Service drinking water standards: Am. Water Works Assoc. Jour., v. 52, no. 3, p. 289-299.