

A.G.

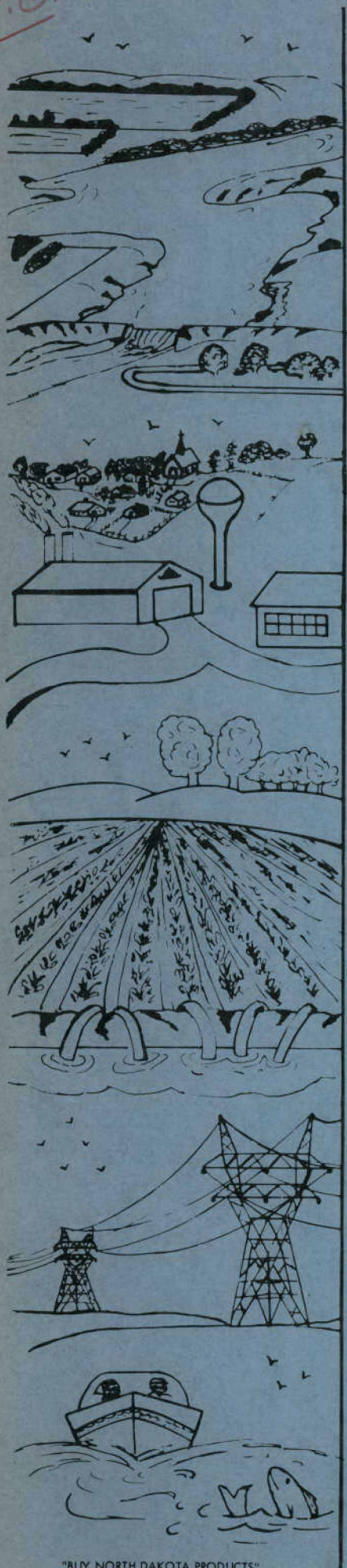

LANSFORD WATER SUPPLY SURVEY
 BOTTINEAU COUNTY, NORTH DAKOTA
 N.D.S.W.C. PROJECT NO. 1357

NORTH DAKOTA GROUND-WATER STUDIES
 NO. 64

By
 Larry L. Froelich
 Ground-water Geologist

PUBLISHED BY
 NORTH DAKOTA STATE WATER COMMISSION
 1301 STATE CAPITOL, BISMARCK, NORTH DAKOTA

-1966-

HYDROLOGIC CYCLE

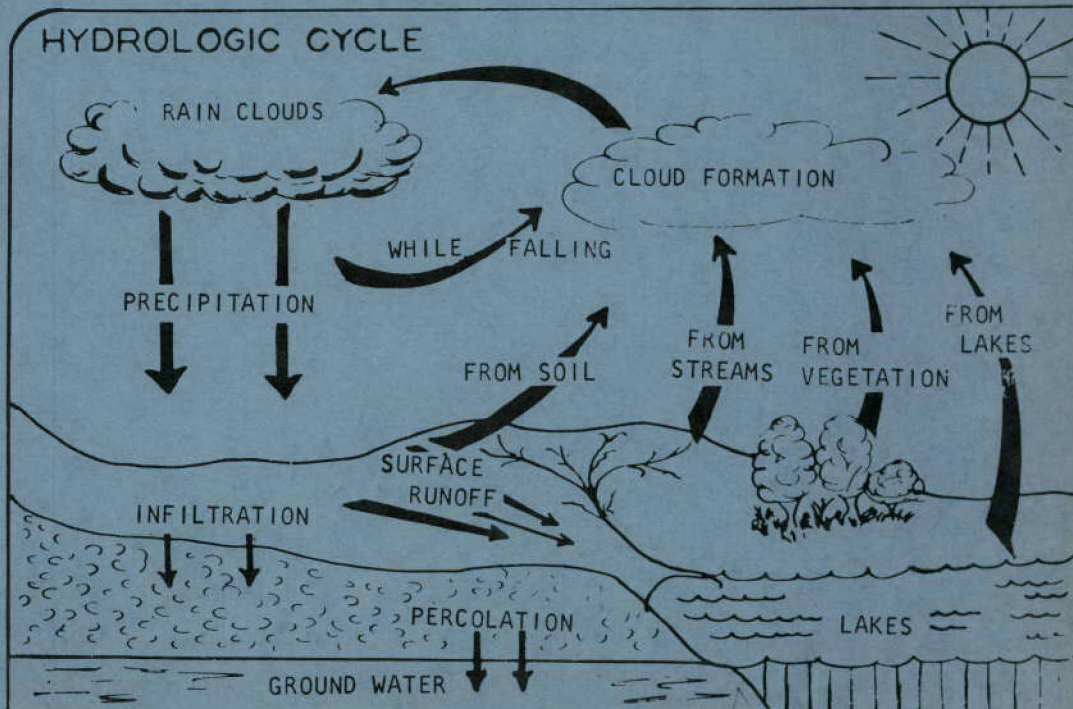

LANSFORD WATER SUPPLY SURVEY
BOTTINEAU COUNTY, NORTH DAKOTA

NORTH DAKOTA STATE WATER COMMISSION, PROJECT NO. 1357

NORTH DAKOTA GROUND-WATER STUDY NO. 64

By
Larry L. Froelich, Ground-water Geologist

Published By:
North Dakota State Water Commission
1301 State Capitol
Bismarck, North Dakota

CONTENTS

	Page
INTRODUCTION	1
Purpose and Scope	1
Location and General Features	1
Present Water Supply	3
Previous Investigations	4
Well-numbering System	6
GEOLOGY AND OCCURRENCE OF GROUND WATER	6
Bedrock	6
Cannonball Formation	8
Tongue River Formation	9
Glacial Drift	9
Till and Associated Sand and Gravel Deposits	10
Meltwater Channel Deposits	11
WATER QUALITY	13
RECOMMENDATION	17
REFERENCES	32

ILLUSTRATIONS

	Page
Figure 1 - Map of North Dakota showing physiographic provinces and location of the Lansford area	2
Figure 2 - System of numbering wells and test holes	5
Figure 3 - Map of the Lansford area showing the location of selected wells, test holes and geologic cross-section A-A'	7
Figure 4 - Geologic cross-section A-A'	12

TABLES

Table 1 - Drinking water standards of the United States Public Health Service	14
Table 2 - Record of chemical analyses	15
Table 3 - Record of wells and test holes	18
Table 4 - Logs of test holes	23

Lansford Water Supply Survey
Bottineau County, North Dakota

INTRODUCTION

Purpose and Scope

In July 1965 the State Water Commission drilled a series of test holes in the Lansford area. Purpose of the test drilling was to locate a suitable municipal water supply for Lansford.

The survey consisted of a selected well inventory, test drilling and observation well installation, chemical analyses of water samples for quality determination, compiling available existing data and preparing an aerial geohydrologic interpretation.

The study was under the direct supervision of the author. Test drilling was done by Lewis Knutson and Jim Haman, using the State-owned hydraulic rotary drilling rig. Chemical analyses were performed by Donald Delzer, State Water Commission Chemist, at the State Laboratories in Bismarck.

Location and General Features

The Lansford area, as described in this report, consists of the 36 square miles included in the north half of Township 159 North, Range 83 West, and the south half of Township 160 North, Range 83 West. The entire area is located in the Central Lowland Physiographic Province of North Dakota as shown in figure 1. Surface elevations vary from 1,550 feet above sea level in Spring Coulee southeast of Lansford to 1,630 feet on the divide between Little Deep Creek and the unnamed coulee immediately west of Lansford.

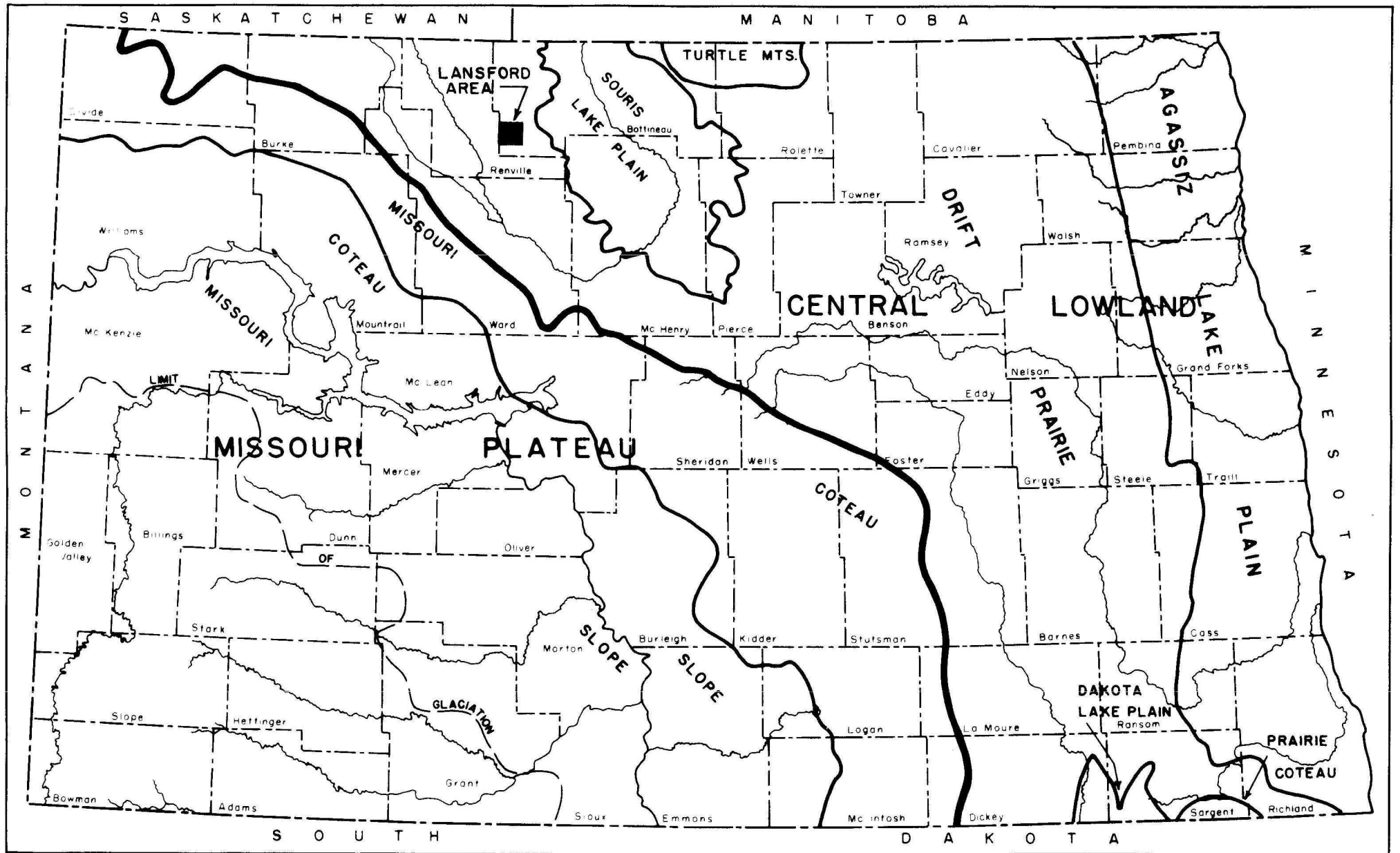

(Modified from Clayton-1962)

FIGURE 1--MAP OF NORTH DAKOTA SHOWING PHYSIOGRAPHIC PROVINCES AND LOCATION OF THE LANSFORD AREA

Drainage in the Lansford area consists of four intermittent streams occupying coulees crossing the area from northwest to southeast. The divides between coulees are nonintegrated and contain numerous shallow depressions or potholes.

Lansford, an agricultural community, has a population of 382 (1960 census). Located $3\frac{1}{2}$ miles west of U. S. Highway 83, it is served by the Great Northern and Minneapolis, St. Paul and Sault St. Marie railroads. U. S. Weather Bureau climatological data recorded at Mohall, 11 miles northwest of Lansford, shows the average temperature to be 40.0°F based on a 71 year record through 1964. Average precipitation based on the same record is 16.64 inches (U. S. Department of Commerce, 1965).

Present Water Supply

The present Lansford water supply is obtained from two wells located beneath the water tower in the east-central part of the village. Well No. 1 was drilled by Ervin Schaefer to a depth of 90 feet in 1957. The well is 6-inches in diameter and equipped with a 2-horsepower submersible pump with 15 gpm (gallons per minute) capacity. Because of extreme hardness and discoloration, water from this well is used only in emergencies. Well No. 2 was drilled by C. A. Simpson and Son later in 1957. It is 300-feet deep, screened and gravel-packed from 270 to 300 feet, 8-inches in diameter and equipped with a 5-horsepower turbine pump with 32 gpm capacity. Water in this well is very soft, highly mineralized, corrosive, and has a salty taste. It is also reported to be gaseous when heated in a hot water heater.

In November 1965 for some undetermined reason, well No. 2 ceased producing. Well No. 1 was put into use with no undue hardship to Lansford

residents other than the poor quality water. At this time, Mayor Hurdlebrink reported (Personal Communication) the Village Council was undecided as to what to do about a future municipal water supply.

Previous Investigations

A general study of the Bottineau County geology and ground-water resources was made by Simpson (1929, pp. 79-88, 276-279) in which he discusses the water-bearing strata of the county and includes a compilation of numerous wells and chemical analyses.

Beginning in midsummer 1945, the United States Geological Survey (Lemke, 1960) began an investigation of a 5,500 square mile area in the Souris River drainage basin to supply basic geologic data to Federal agencies engaged in the Missouri River Basin Development Program.

Concurrent with the Souris River Basin geologic study, the Water Resources Division of the United States Geological Survey conducted a hydrologic study of 4,300 square miles within the drainage basin of the Souris River. The interpretive report (LaRocque, Swenson, and Greenman, 1963a) was published as North Dakota Ground-water Study No. 54. An open-file report (LaRocque, Swenson, and Greenman, 1963b) containing tables of data collected during the study is available for consultation at the United States Geological Survey or the North Dakota State Water Commission offices in Bismarck, North Dakota.

In May 1963 township assessors, at the request of the State Water Commission, inventoried most of the water wells in Bottineau County. This inventory will assist in planning the county-wide ground-water survey of Bottineau County.

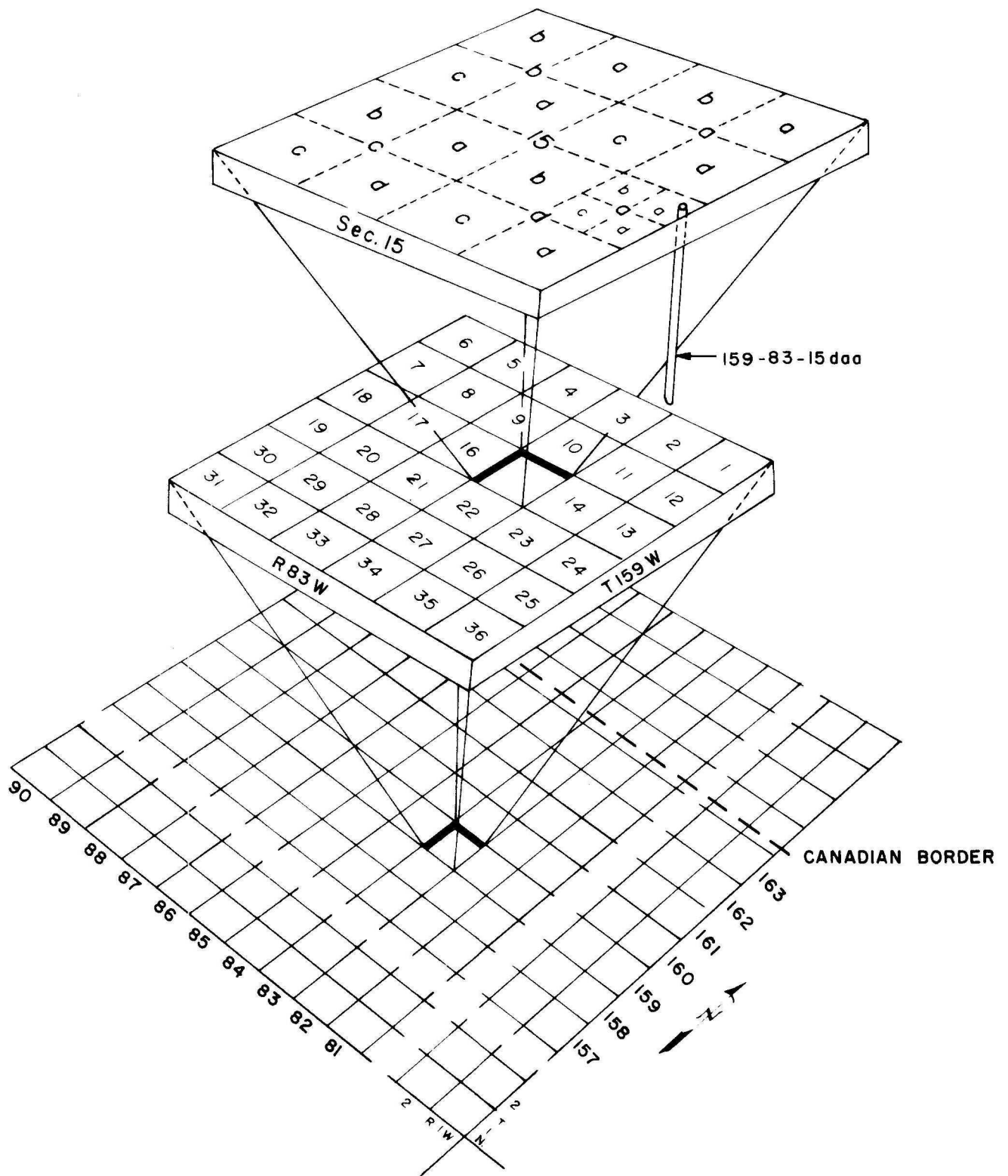

FIGURE 2--SYSTEM OF NUMBERING WELLS AND TEST HOLES.

Well-numbering System

The well-numbering system used in this report illustrated in figure 2, is based on the location of the well in the Federal system of rectangular surveys of public lands. The first number denotes the township north and the second number denotes the range west, both referred to the fifth principal meridian and base line. The third number denotes the section in which the well is located. The letters a, b, c, and d designate respectively the northeast, northwest, southwest, and southeast quarter sections, quarter-quarter sections and quarter-quarter-quarter sections (10-acre tracts). Consecutive terminal numbers are added if more than one well is located in a 10-acre tract. Thus, well 159-83-15daa would be located in the NE $\frac{1}{4}$, NE $\frac{1}{4}$, SE $\frac{1}{4}$, Sec. 15, Twp. 159 N., Rge. 83 W.

GEOLOGY AND OCCURRENCE OF GROUND WATER

Contrary to the popular belief that ground water occurs in 'veins' or underground rivers and lakes, scientific investigations have proven that nearly everywhere, at varying depths, porous material composing the earth's crust is saturated with water. It is the geologic structure and composition of the material that determines whether water can be withdrawn in sufficient quantity for an intended purpose from a well penetrating the material. Because the occurrence of ground water is dependent upon geologic relationships, the two must be examined simultaneously to determine ground-water availability in any given area.

Bedrock

Surficial deposits in the Lansford area consist of glacial drift or those materials that accumulated during Pleistocene glaciation. The glacial

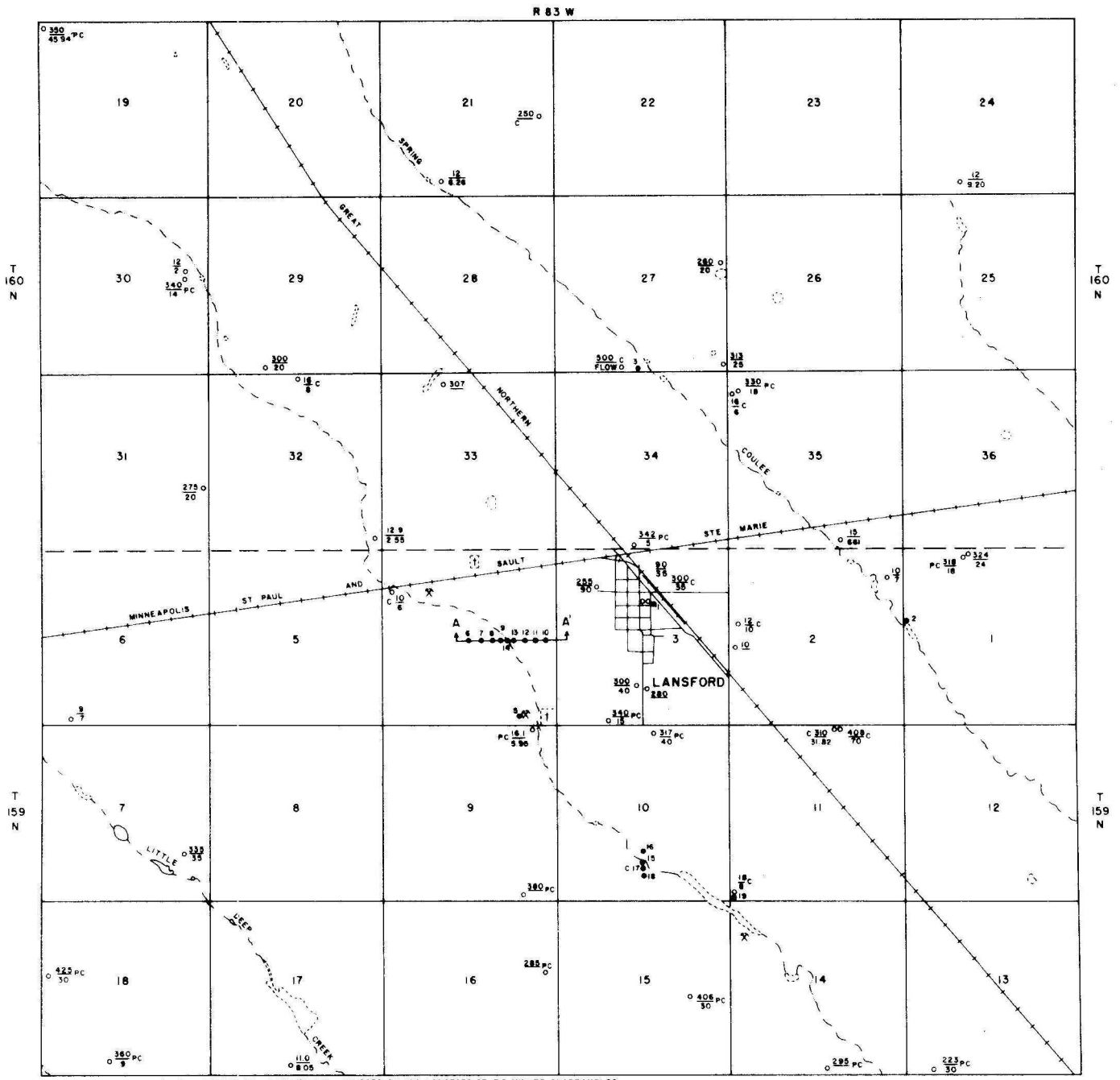

BASE PREPARED FROM U.S.G.S. LANSFORD NE, LANSFORD NW, LANSFORD SW AND LANSFORD SE 7.5 MINUTE QUADRANGLES

- NO TEST HOLE
- PC INDICATES PARTIAL ANALYSIS
- C INDICATES CHEMICAL ANALYSIS
- X GRAVEL PIT

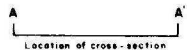

32.4 WATER WELL UPPER NUMBER INDICATES DEPTH OF WELL LOWER NUMBER INDICATES DEPTH TO WATER

FIGURE 3--LANSFORD AREA MAP SHOWING LOCATION OF SELECTED WELLS, TEST HOLES AND GEOLOGIC CROSS SECTION A-A'

deposits, in turn, are underlain by more than 6,000 feet of consolidated sedimentary rocks collectively known as bedrock. These sediments are separated into formations correlative with their deposition during specific periods of geologic time. Water wells tap two bedrock formations in the Lansford area. These are the Cannonball and Tongue River Formations deposited during the Tertiary System of geologic time.

Cannonball Formation - The Cannonball Formation and the overlying Tongue River Formation are treated as the Cannonball and Tongue River Members of the Fort Union Formation by Lemke (1960) and LaRocque, et.al. (1963 a and b). Because the two units contain separate physical, lithologic, and hydrologic characteristics and can be differentiated in the subsurface as well as at the surface in areas where they crop out, they are treated as separate formations of the Fort Union Group in this report.

At the beginning of Tertiary time, a large inland sea covered central and western North Dakota and deposited the sediments of the Cannonball Formation. In the Lansford area, the Cannonball Formation consists, for the most part, of dark greenish gray, fine-grained sandstone. The sandstone is usually soft and friable; however, a three-foot layer of cemented sandstone was encountered in test hole 1 (159-83-3acb, see figure 3, Table 4).

The Cannonball Formation underlies the entire Lansford area, but its total thickness is not definitely known. The upper contact was determined from the electric log of test hole 1 at a depth of 293 feet. Well 160-83-27cdc (Table 3) at a depth of 500 feet is believed to be developed in the Cannonball Formation, indicating the formation is at least 207 feet thick. Several wells have been developed in the Cannonball Formation and produce sufficient water for ordinary domestic and livestock demands. Lansford well No. 2 was producing 32 gpm from the upper part of the formation.

Water levels are generally within 30 feet of the land's surface, indicating the formation is under hydrostatic pressure. Well 160-83-27cdc is flowing. Ground-water recharge has been determined to be from the south and southwest (LaRocque et.al., 1963a). Discharge is primarily through water wells.

Tongue River Formation - Following the retreat of the Cannonball sea continental sediments spread over the area from the west. The sediments were deposited, for the most part, in swamps and shallow lakes. Shifting of the water bodies during accumulation caused the resulting layers to be discontinuous and uneven in thickness which characterizes the Tongue River Formation.

In the Lansford area, the Tongue River Formation consists of interbedded shale and soft sandstone. Test drilling indicates it does not underlie the entire area. It was absent in test hole 2 (159-83-1bcc) east of Lansford, therefore, the thickness is variable. The shales encountered during test drilling varies in color from light gray to black and were smooth-textured and tight. The sands were light greenish gray to greenish gray and frequently contained brownish black carbonaceous (decayed vegetation) streaks. Lignite, common to the Tongue River Formation, was not encountered during test drilling. Wells developed in the Tongue River Formation usually provide sufficient water for ordinary domestic or livestock demands. Water levels reportedly vary from 15 to 90 feet below land surface. The fine-grained nature of the sediments and poor hydrologic connections preclude the development of wells yielding more than 5 to 10 gpm.

Glacial Drift

Glaciers, heavily laden with bedrock materials and glacial debris which had been picked up and transported by the ice, moved south and

southeastward across the Lansford area, during the Pleistocene Epoch. When the margin of the glaciers retreated to the north, the rock material transported by the glaciers was left as a mantle on the surface overridden by the ice. Meltwater streams adjacent to the margin of the retreating ice cut channels into the drift and in some instances, deposited sand and gravel. The present land surface in the Lansford area is essentially as the ice and meltwater left it.

Glacial drift refers to all stratified or unstratified materials deposited directly or indirectly by glacial action. Glacial drift is present throughout the entire Lansford area with the average thickness approximating 234 feet. Total thickness of drift varied from 194 feet in test hole 3 to 274 feet in test hole 2.

Till and Associated Sand and Gravel Deposits - Till makes up the greatest percentage of glacial drift in the Lansford area. Till is characterized by an unstratified mixture of clay, silt, sand, pebbles, cobbles, and boulders deposited directly by the glacier with little or no transportation by water. When till occurs above the water table, it is characterized by yellow or red oxidization stains. Till below the water table is olive gray in color and locally termed "blue clay." The till in the Lansford area consists essentially of clay and silt and is too fine-grained to readily yield water to wells.

Stratified sand and gravel deposits are commonly associated with till. These deposits will yield water to wells, but because most are local and have small aerial extent, they become dewatered by continuous pumping. When pumping is discontinued, the water level will slowly recover as a result of recharge through the surrounding till and the well can again be pumped for a certain period. Lansford well 1 is one of the very few wells

in the area developed in deposits associated with till.

Meltwater Channel Deposits - The natural topographic dip in the Lansford area is to the northeast. However, Spring Coulee, Little Deep Creek and two unnamed tributaries flow to the southeast. As the last glacier retreated from the area, the region southwest of Lansford was the first to be exposed because of its higher elevation. Because the natural drainage to the northeast was still blocked by ice, the water was forced to flow to the next lowest elevation which was to the southeast. Climatic fluctuations and/or seasonal variations caused a temporary halt to the glacier's recession and meltwater streams eroded a channel adjacent to the margin of the ice. With each successive retreat of the ice, the old channel was abandoned in favor of a new channel formed at a lower elevation to the northeast. Thus, a series of parallel meltwater channels trending perpendicular to the regional dip of the area was created.

Very little material was deposited in the channel itself, because the meltwater was eroding the channels. Associated with the channels are local, isolated and discontinuous deposits of sand and gravel which accumulated along the ice front and are correctly termed ice-contact deposits. Because ice-contact deposits are closely associated with the meltwater channels, they are included in this section of the report. Ice-contact deposits in this area are usually confined to one side of the channel only. Cross-section A-A' (figure 4) was drilled across the unnamed coulee west of Lansford to determine the channel profile. The purpose of the test holes was twofold. First, the thickness and extent of the sand and gravel believed to exist in the channel had to be determined. Secondly, this location, because of its close proximity to the village, would make an ideal site for a surface water retention dam for a municipal

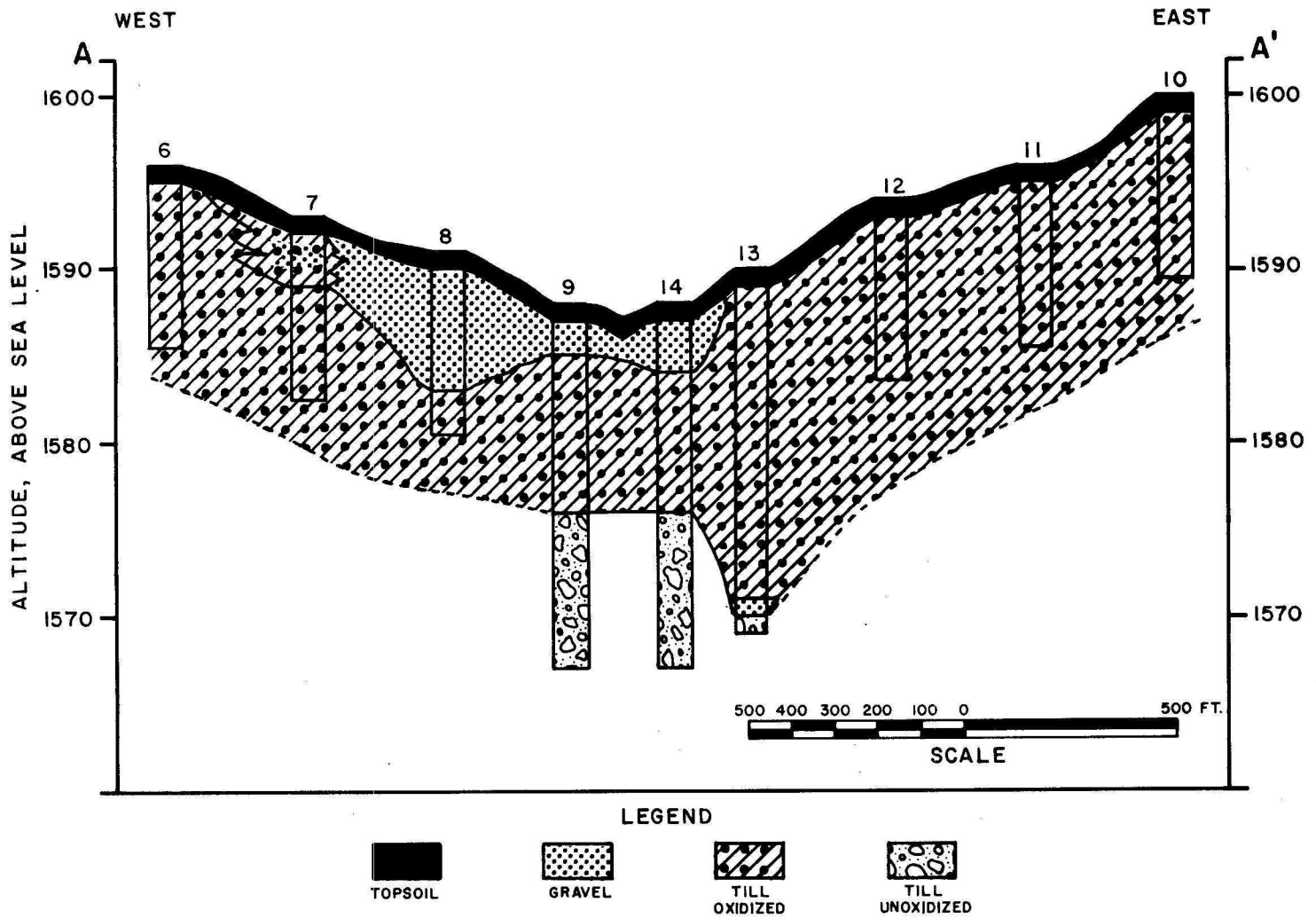

FIGURE 4 -- CROSS-SECTION A - A'
 (LOCATION OF CROSS-SECTION SHOWN IN FIGURE 3)

water supply in the event a suitable ground-water source could not be located. Saturated sand and gravel capable of supplying a municipal well was not encountered.

A preliminary study of the hydrology of this coulee, considering its drainage area, average precipitation and anticipated runoff, revealed the amount of water contained in the channel throughout the year would sufficiently supply the Village of Lansford. Substantiating this fact is the W.P.A. dam on the same channel southeast of Lansford. The water level in the reservoir reportedly fluctuates very little during the year unless the summer is exceptionally hot and dry.

Several large-diameter, shallow, low-yielding wells have been dug along the meltwater channels in the Lansford area. The wells supply ordinary domestic or livestock demands and drinking water has been or is presently being hauled from many of these wells to village residents and to neighboring farmers who own deep bedrock wells. Water from the shallow wells is more palatable and more desirable for cooking. The sand and gravel deposits are recharged by snow melt and precipitation during the spring and early summer. Water levels in the shallow wells are highest at this time. During the summer and fall, however, the stored ground water slowly percolates downstream by natural discharge along the axis of the channel. Water levels are usually the lowest prior to the first heavy frost in the fall. The water level will slowly recover during the winter.

WATER QUALITY

Ground water is primarily derived from rain and snowmelt. The amount and character of minerals dissolved by the water depends on the physical and chemical composition of the rocks it contacts, the duration of contact, temperature, pressure, and gases and minerals already in solution.

The quality of water for public supply and domestic use is commonly evaluated in relation to standards of the United States Public Health Service for drinking water. Table 1 lists, in part, standards adopted by the United States Public Health Service.

Table 1 - - Drinking water standards of the United States Public Health Service

Iron (Fe)	3ppm (Parts per million)
Magnesium (Mg)	125ppm
Sulfate (SO ₄)	250ppm
Chloride (Cl)	250ppm
Fluoride (F)	1.5ppm
Nitrate (NO ₃)	45ppm
Total dissolved solids	500ppm

The presence of sodium in water may affect persons suffering from heart, kidney, or circulatory ailments. When a strict sodium-free diet is recommended, any water should be tested and persons so affected should rely on their physician's advice. Because individual intake of sodium varies, no recommended limit for sodium is established.

Table 2 lists 27 complete and partial analyses from representative waters in the Lansford area. All partial analyses were taken from LaRocque et. al. (1963b). All complete analyses, with the exception of 159-83-3a (Simpson, 1929), were performed at the State Laboratories in Bismarck.

The Cannonball Formation contains highly mineralized sodium chloride type water. The water, similar to sea water but approximately 1/10 as concentrated, acquires its poor quality from water and minerals entrapped in the sediments as they were deposited in the Cannonball sea. The water is moderately soft and is preferred for laundering. High concentrations

TABLE 2 - CHEMICAL ANALYSES
(analytical results in parts per million except as indicated)

Location	Depth of well (feet)	Aquifer	Date of collection	Silica (SiO ₂)	Total Iron (Fe)	Calcium (Ca)	Magnesium (Mg)	Sodium (Na)	Potassium (K)	Bicarbonate (HCO ₃)	Carbonate (CO ₃)	Sulfate (SO ₄)	Chloride (Cl)	Fluoride (F)	Nitrate (NO ₃)	Boron (B)	Total dissolved solids	Hardness as CaCO ₃		% Sodium	Sodium absorption ratio	Specific conductance (micromhos 25°C)	pH	Temp °F		
																		Calcium Magnesium	Noncarbonate							
159-83-1bab	318	Tc	10-22-47	-	-	-	-	-	-	955	-	-	950	-	-	-	-	-	-	-	-	-	4,060	-	-	1/
159-83-2bcc	12	Qd	7-16-65	15	1.8	323	84	31	13	388	0	820	43	0.0	0.9	.20	1,700	1,150	833	5	0.4	1,890	7.2	44		
159-83-3a	254	Tc	5-18-21	9.8	1.9	14	4.3	1,026	-	84E	0	12	1,135	-	trace	-	2,651	53	-	-	-	-	-	-	2/	
159-83-acb	300	Tc	7-16-65	6.0	.34	12	1.7	1,030	2.2	860	0	36	1,100	0.6	1.3	3.1	2,650	37	0	98	74	4,450	8.2	48		
159-83-3cdc	340	Tt	10-24-47	-	-	-	-	-	-	1,060	-	-	785	-	-	-	-	-	-	-	-	-	3,660	-	-	1/
159-83-4bcb	10	Qd	7-16-65	18	.14	147	33	34	16	388	0	245	8.5	.1	5.3	0.0	725	502	184	12	.7	1,020	7.5	46		
159-83-9aab	16.1	Qd	8-22-51	-	-	-	-	-	-	-	-	140	-	-	-	-	-	-	-	-	-	-	898	-	-	1/
159-83-9ddc	380	Tc	10-24-47	-	-	-	-	-	-	810	-	-	1,350	-	-	-	-	-	-	-	-	-	5,150	-	-	1/
159-83-10abb	317	Tt	10-24-47	-	-	-	-	-	-	1,000	-	-	770	-	-	-	-	-	-	-	-	-	3,710	-	-	1/
159-83-10cda2	28	Qd	7-16-65	37	11	548	684	1,200	15	508	0	6,270	103	.9	11	1.1	10,400	4,180	3,770	38	81	8,720	8.0	53		
159-83-11abb1	310	Tc	6-14-47	11	-	23	11	1,180	6.4	736	14	61	1,420	.4	8.0	3.1	3,100	103	0	96	-	-	5,450	8.2	-	1/
159-83-11abb2	408	Tc	7-16-65	2.0	11	84	43	800	8.2	316	0	880	709	.1	1.8	1.7	2,720	385	126	81	18	4,249	7.8	46		
159-83-11ccc	18	Qd	7-16-65	17	.1	100	29	17	7.6	297	0	136	3.5	.2	23	.32	551	370	127	9	.4	791	7.6	48		
159-83-13ccc	223	Tt	10-22-47	-	-	-	-	-	-	945	-	-	795	-	-	-	-	-	-	-	-	-	3,700	-	-	1/
159-83-14dcc	295	Tc	10-23-47	-	-	-	-	-	-	920	-	-	990	-	-	-	-	-	-	-	-	-	4,240	-	-	1/
159-83-15aab	Surface water	W. P. A. dam	7-16-65	1.0	.26	62	12	14	16	177	39	30	1.5	.3	8.9	0.0	312	202	74	12	.4	411	9.3	72		
159-83-15dba	406	Tc	10-24-47	-	-	-	-	-	-	720	-	-	1,830	-	-	-	-	-	-	-	-	-	6,330	-	-	1/
159-83-16add	285	Tc	10-24-47	-	-	-	-	-	-	825	-	-	1,180	-	-	-	-	-	-	-	-	-	4,710	-	-	1/
159-83-18bcc	425	Tc	10-24-47	-	-	-	-	-	-	1,010	-	-	1,040	-	-	-	-	-	-	-	-	-	4,500	-	-	1/
159-83-18cdd	360	Tc	10-24-47	-	-	-	-	-	-	820	-	-	1,330	-	-	-	-	-	-	-	-	-	5,050	-	-	1/
160-83-19bbb	350	Tc	10-23-47	-	-	-	-	-	-	870	-	-	900	-	-	-	-	-	-	-	-	-	3,800	-	-	1/
160-83-21daa	250	Tt	6-1-48	11	-	46	10	823	7.2	618	38	520	596	.4	8.7	1.9	2,370	156	0	92	-	-	3,460	8.4	-	1/
160-83-27cdc	500	Tc	7-16-65	9.4	1.7	16	3.4	926	3.2	946	0	48	929	.4	2.2	2.6	2,410	54	0	97	55	-	4,070	8.2	43	
160-83-30adc1	360	Tc	10-23-47	-	-	-	-	-	-	520	-	-	2,440	-	-	-	-	-	-	-	-	-	7,640	-	-	1/
160-83-32abb	16	Qd	7-16-65	19	4.6	102	29	8.1	7.3	293	0	91	5.0	.2	104	0.0	564	375	135	4.4	.2	762	7.8	-		
160-83-34dcc	342	Tc	10-23-65	-	-	-	-	-	-	710	-	-	1,960	-	-	-	-	-	-	-	-	-	6,540	-	-	1/
160-83-35bbb1	330	Tc	10-23-65	-	-	-	-	-	-	620	-	-	1,970	-	-	-	-	-	-	-	-	-	6,490	-	-	1/
160-83-35bbb2	16	Qd	7-16-65	14	1.1	98	23	28	7.5	331	0	111	12	.3	5.3	.32	487	340	69	15	.7	733	7.7	48	1/	

1/ LaRocque, et al., 1963

2/ Simpson, 1929

of boron, sodium, and total dissolved solids make the water unsuitable for irrigation, washing cars and making coffee. High chloride concentrations impart a salty taste to the water which is also highly corrosive. It is undesirable for a municipal supply.

Water from the Tongue River Formation can be classed as either sodium bicarbonate or sodium sulfate. Bicarbonate has no noticeable effects on persons consuming that type of water but sulfates exert a laxative effect on persons unaccustomed to the water. Sodium concentrations and total dissolved solids are too high to permit water from the Tongue River Formation to be used for irrigation. It, too, is undesirable for a municipal supply.

Quality of glacial drift aquifers varies considerably. Where water is abundant, it is commonly potable; where confined, it is highly mineralized. Drift water is of the calcium bicarbonate or calcium sulfate type. It is hard and generally contains excessive iron. Water from test hole 17 (Table 2, 159-83-10cda₂), would be entirely objectionable for a municipal supply, whereas, water from well 159-83-11ccc would be completely satisfactory.

Well 159-83-11ccc is located adjacent to the reservoir created by the W.P.A. dam and naturally would receive recharge from the reservoir if the well were pumped continuously. A sample of water was obtained from the reservoir in the event Lansford decided to use surface water for a municipal supply. Water in the reservoir (Table 2) is of exceptionally good quality and would need little treatment other than chlorination. The only objection would be the temperature of the water during the summer and fall months.

RECOMMENDATION

This investigation revealed that waters from bedrock formations are chemically undesirable for a municipal supply. Sand and gravel deposits associated with till are usually confined and subject to dewatering. Water in these deposits is also highly mineralized and generally very hard. Ice-contact deposits associated with the meltwater channels are too shallow and discontinuous to constitute a source of municipal water supply. The quality of meltwater channel deposits, in most cases, would be acceptable for a municipal supply.

It is recommended that Lansford carefully consider the possibilities of surface water for their municipal supply. The reservoir created by the W.P.A. dam is a potential source of good quality water and would require approximately $1\frac{1}{2}$ to 2 miles of pipeline. If a dam was constructed in Section 4 (See figure 4) immediately west of the golf course, a shorter pipeline would be required. If this site were to be chosen, potential recreational facilities for the village would also be created.

TABLE 3 - RECORDS OF WELLS AND TEST HOLES

Depth to water: Measured water levels in feet and tenths or hundredths; reported water levels in feet.

Depth of well: Measured depths in feet and tenths; reported depths in feet.

Type of well: Dr, drilled; Du, dug; Aquifer: Qd-glacial drift
Tt-Tongue River Formation; Tc-Cannonball Formation

Use of water: D, domestic; U, unused; PS, public supply; S, stock; T, test hole

Location No. (1)	Owner (2)	Depth (feet) (3)	Diameter (inches) (4)	Type (5)	Date Completed (6)	Depth to water below land surface (feet) (7)	Date of measurement (8)	Use of water (9)	Aquifer (10)	Remarks (11)	Elev. MSL (12)
159-83 1bab	J. Talley	318	6	Dr		18	10-8-47	U	Tc/sandstone	Part, chem. anal.	1586
1bab	Joe Talley	324	4	Dr	1957	24	-	D,S	Tc/sandstone	Soft, haul drinking water	1586
1bcc	Test Hole #2	294	4 3/4	Dr	7-7-65	-	-	T	-	See log	1555
2aad	T. Nelson	10	40	Du	-	7	10-8-47	U	Qd/sd. and gr.	-	1565
2bcc	Peter Le Clair	12	48	Du	1940	10	-	D,S	Qd/	Chem. Anal.	1600
2cbb	Lester Convass	10	40	Du	-	-	-	D,S	Qd/	-	1598
3a	Village of Lansford	254	4	Dr	-	3	5-10-21	U	Tc/sandstone	Chem. Anal.	-
3acb ₁	Village of Lansford	90	4	Dr	1957	35	11- -65	PS	Qd/gravel	-	1607
3acb ₂	Village of Lansford	300	6	Dr	1957	35	11- -65	PS	Tc/sandstone	Chem. Anal.	1607

TABLE 3 - RECORDS OF WELLS AND TEST HOLES - Cont.

(1)	(2)	(3)	(4)	(5)	(6)	(7)	(8)	(9)	(10)	(11)	(12)
159-83 (Cont.)											
3acb ₃	Test Hole #1	315	4 3/4	Dr	7-6-65	-	-	T	-	See log	1610
3bbd	Francis Bradley	255	-	Dr	1915	90	-	D,S	Tt/	Soft, salty	1609
3cda	Bernice Timms	300	4	Dr	8-1-62	40	-	D,S	Tt/	Soda, salty	1610
3cdc	Delmar Bradley	340	6	Dr	-	15	-	D,S	Tt/	Part. Chem. Anal.	1602
3dcb	Roy Helming	280	4	Dr	-	-	-	S	-/shale	-	1607
4bcb	Sam Martinson	10	36	Du	1924	6	-	D	Qd/sd. & gr.	Chem. Anal.	1592
4caa	Test Hole #6	10½	4 3/4	Dr	7-12-65	-	-	T	-	See log	1596
4daa ₁	Test Hole #10	10½	4 3/4	Dr	7-13-65	-	-	T	-	See log	1600
4daa ₂	Test Hole #11	10½	4 3/4	Dr	7-13-65	-	-	T	-	See log	1596
4dab ₁	Test Hole #12	10½	4 3/4	Dr	7-13-65	-	-	T	-	See log	1594
4dab ₂	Test Hole #13	21	4 3/4	Dr	7-13-65	-	-	T	-	See log	1590
4dba ₁	Test Hole #14	21	4 3/4	Dr	7-13-65	-	-	T	-	See log	1588
4dba ₂	Test Hole #5	21	4 3/4	Dr	7-12-65	-	-	T	-	See log	1588
4dbb ₁	Test Hole #8	10½	4 3/4	Dr	7-12-65	-	-	T	-	See log	1591
4dbb ₂	Test Hole #7	10½	4 3/4	Dr	7-12-65	-	-	T	-	See log	1593
4ddc	Test Hole #5	21	4 3/4	Dr	7-12-65	-	-	T	-	See log	1595
5aad	Test Hole #4	263½	4 3/4	Dr	7-8-65	-	-	T	-	See log	1590

TABLE 3 - RECORDS OF WELLS AND TEST HOLES - Cont.

(1)	(2)	(3)	(4)	(5)	(6)	(7)	(8)	(9)	(10)	(11)	(12)
159-83 (Cont.)											
6ccc	Melvin Hoberg	9	36	Du	1903	7	-	D	Qd/	-	1620
7dac	William McLeod	335	6	Dr	-	35	-	D,S	Tc/	Salty	1615
9aab	Martinson Estate	16.1	48	Du	-	5.95	10-7-45	U	Qd/gravel	Part. Chem. Anal.	1592
9ddc	McLeod	380	6 to 3	Dr	-	-	-	D,S	Tc/shale,sand	Part. Chem. Anal.	1619
10abb	Leslie Heath	317	6	Dr	-	40	-	D,S	Tt/	Part. Chem. Anal.	1607
10cad	Test Hole #16	21	4 3/4	Dr	7-14-65	-	-	T	-	See log	1581
10cda ₁	Test Hole #15	21	4 3/4	Dr	7-14-65	-	-	T	-	See log	1585
10cda ₂	Test Hole #17	42	4 3/4	Dr	7-14-65	14	7-15-65	T	Qd/sand	Chem. Anal.	1587
10cda ₃	Test Hole #18	241½	4 3/4	Dr	7-15-65	-	-	T	-	-	1590
11abb ₁	Lynn Helming	310	3	Dr	-	31.82	6-14-47	S	Tc/	Chem. Anal.	1598
11abb ₂	Lynn Helming	408	6	Dr	-	70	-	D,S	Tc/	Chem. Anal.	1598
11ccc ₁	Herbert Helming	18	18	Du	1923	8	-	PS	Qd/sand	Chem. Anal.	1585
11ccc ₂	Test Hole #19	42	4 3/4	Dr	7-15-65	-	-	T	-	See log	1585
13ccc	Raymond Undlin	223	5	Dr	-	30	10-10-47	S	Tt/	Part. Chem. Anal.	1594
14dcc	William Rutledge	295	6 to 4	Dr	-	Dry	3-27-63	U	Tc/	Part. Chem. Anal. before it went dry	1592
15dba	Clarence Rutledge	406	4 to 2	Dr	6- -46	30	-	D,S	Tc/	Part. Chem. Anal.	1606
16add	M. Nesvig	285	3	Dr	-	-	-	S	Tc/	Part. Chem. Anal.	1619
17cdd	Donald Zeitz	11.0	48	Du	-	8.05	10-7-45	D,S	Qd/Sd.,Gr.	-	1608

TABLE 3 - RECORDS OF WELLS AND TEST HOLES - Cont.

(1)	(2)	(3)	(4)	(5)	(6)	(7)	(8)	(9)	(10)	(11)	(12)
<u>159-83</u> (Cont.)											
18bcc	Norris Railing	425	4	Dr	1915	30	-	D,S	Tc/shale	Part. Chem. Anal.	1656
18cdd	Ivar Roen	360	6	Dr	1916	9	-	D,S	Tc/	Part. Chem. Anal.	1652
<u>160-83</u>											
19bbb	Elden Otto	350	3 to 2	Dr	-	45.94	10-7-47	S	Tc/	Part Chem. Anal.	1624
21cd	Henry Kraack	12	48	Du	-	6.26	10-7-47	U	Qd/gravel	-	1565
21daa	J. Otten	250	4 to 2	Dr	-	-	-	D,S	Tt/	Chem. Anal.	1601
24cd	C.L. O'Keefe	12	40	Du	1902	9.20	10-8-47	D,S	Tc/sand	-	1566
27ad	Bryan Dean	260	3 to 2	Dr	-	20	10-7-47	S	-/gravel(?)	-	1591
27cdc	Hortense Hammer	500	6	Dr	1918	Flow	7-8-65	D,S	Tc/	Chem. Anal.	1572
27cdd	Test Hole #3	231	4 3/4	Dr	7-8-65	-	-	T	-	See log	1560
27ddd	Marvin Dean	313	4	Dr	1953	25	-	D,S	Tc/	Soda, iron, salty	1590
29cdc	Milton Holmes	300	4	Dr	1951	20	-	D,S	Tc/	Soft, salty	1612
30adc ₁	Alvin Larson	340	3 to 2	Dr	1947	14	-	S	Tc/	Part. Chem. Anal.	1606
30adc ₂	Alvin Larson	12	24	Du	1944	2	-	D	Qd/	Hard, good	1601
31dad	Robert Smetana	275	4	Dr	-	20	-	D,S	Tc/	Soft, salty	1624
32abb	Albert Smetana	16	36	Du	1960	8	-	PS,S	Qd/gravel	Chem. Anal.	1610
32ddd	C. H. Aus	12.9	36	Du	-	2.55	-	S	Qd/gravel	-	1602

TABLE 3 - RECORDS OF WELLS AND TEST HOLES - Cont.

(1)	(2)	(3)	(4)	(5)	(6)	(7)	(8)	(9)	(10)	(11)	(12)
<u>160-83</u> (Cont.)											
33ba	Irvey Iverson	307	3 to 2	Dr	1907	-	-	U	Tc/sand	Soft, salty	1612
34dcc	Ole Holmes	342	4 to 2	Dr	1925	5	-	D	Tc/sand	Part. Chem. Anal.	1601
35bbb ₁	Emil Vedvig	330	4 to 2	Dr	1943	18	10-7-47	U	Tc/	Part. Chem. Anal.	1581
35bbb ₂	Emil Vedvig	16	48	Du	1950	6	-	D	Qd/sand	Chem. Anal.	1577
35dcd	J. C. Johnson	15	24	Du	-	6.61	10-8-47	U	Qd/gravel	-	1567

TABLE 4--Logs of Test Holes

159-83-1bcc
Test Hole 2

<u>Formation</u>	<u>Material</u>	<u>Thickness</u> (feet)	<u>Depth</u> (feet)
Glacial drift:	Topsoil, silty loam, black -----	2	2
	Gravel, fine and medium, sandy, subrounded, rusty -----	3	5
	Clay, silty and sandy with pebbles, dusky yellow, soft, oxidized (Till)-	4	9
	Clay, silty with sand grains and pebbles, olive gray, soft, cohesive (Till) -----	24	33
	Sand, medium, light gray, well-sorted subrounded, quartzose -----	4	37
	Clay, silty to sandy with pebbles, olive gray, moderately soft, cohesive (Till) -----	25	62
	Clay (Till), as above, with lenses of loose, light gray, rounded, medium- grained sand -----	11	73
	Clay, silty to sandy with pebbles, olive gray, moderately soft, very cohesive (Till); contains occasional thin lenses of sand and/or gravel --	93	166
	Sand and gravel lensed with clay, silt, and till, poorly-sorted, highly lignitic, dirty; rough drilling in spots -----	58	224
	Clay, sandy, olive gray, soft, moderately cohesive; drills easy ---	23	247
	Gravel, fine and medium, sandy with some coarse gravel, sorted; rough drilling -----	6	253
	Boulder, granite -----	2	255
	Clay, sandy with lenses of silt and loose sand, olive gray, soft; drills easy -----	26	281
	Cannonball Formation:	Sand, fine to medium, dark greenish gray with brown and black carbon- aceous streaks, friable, micaceous, noncalcareous -----	13
	electric log		

<u>Formation</u>	<u>Material</u>	<u>Thickness</u> (feet)	<u>Depth</u> (feet)
159-83-3acb Test Hole 1			
Glacial Drift:	Topsoil, silty loam, black -----	1	1
	Silt, clayey to sandy, yellowish gray, soft, loose -----	4	5
	Clay, silty, black, cohesive -----	2	7
	Clay, silty, yellowish gray, soft, cohesive -----	3	10
	Clay, very silty and sandy with pebbles, dusky yellow, soft, moder- ately cohesive, oxidized (Till)----	10	20
	Clay, very silty and sandy with pebbles, olive gray, soft, cohesive, unoxidized (Till); contains lenses of loose sand and fine gravel -----	13	33
	Clay, silty with sand grains and pebbles, olive gray, soft to moder- ately soft, cohesive (Till) -----	23	56
	Sand, fine and medium, some fine gravel, light olive gray, well-sorted, sub- rounded, lensed with thin silt stringers -----	9	65
	Clay, silty with lenses of fine to medium sand, olive gray, soft -----	9	74
	Clay, silty with sand grains and pebbles, olive gray, moderately soft, cohesive (Till) -----	32	106
	Clay, silty, olive gray, soft, smooth, cohesive, plastic -----	4	110
	Clay, silty and sandy with pebbles and occasional lenses of sandy clay and silt, olive gray, soft to moderately soft (Till) -----	36	146
	Clay, very sandy with numerous pebbles but very few rocks, olive gray, moder- ately soft, moderately cohesive, tightly compacted (Till) -----	76	222
	Gravel, fine and medium, moderately well-sorted, subangular and sub- rounded, mostly limestone and granitic particles -----	8	230
	Clay, sandy with pebbles and loose gravelly lenses, olive gray, moder- ately soft and cohesive (Till); moder- ately rough drilling -----	10	240

<u>Formation</u>	<u>Material</u>	<u>Thickness (feet)</u>	<u>Depth (feet)</u>
159-83-3acb Test Hole 1 (cont.)			
Tongue River Formation:			
	Shale, light olive gray, soft, plastic, cohesive, tight -----	6	246
	Sand, light greenish gray, soft, friable, slightly calcareous, micaceous, lignitic -----	18	264
	Shale, olive gray to purplish gray, soft, smooth, cohesive -----	4	268
	Sand, light gray with black mica and lignite flakes, fine-grained, sub-angular, slightly frosted appearance -	8	276
	Shale, sandy to silty, dark reddish gray, moderately soft, moderately cohesive, tight -----	17	293
Cannonball Formation (1):			
	Sand, dark greenish gray, fine-grained, soft, friable -----	11	304
	Sandstone, light greenish gray, indurated, highly calcareous -----	3	307
	Sand, dark greenish gray with brownish gray carbonaceous streaks, fine-grained, soft, friable -----	8	315
159-83-4caa Test Hole 6			
Glacial Drift:			
	Topsoil, sandy loam, black -----	1	1
	Clay, very silty and sandy with pebbles, yellowish gray, soft, slightly to moderately cohesive, oxidized (Till) -	9½	10½
159-83-4daa ₁ Test Hole 10			
Glacial Drift:			
	Topsoil, sandy silt loam, black -----	1	1
	Clay, silty and sandy with pebbles, yellowish gray, soft, slightly to moderately cohesive, oxidized (Till) -	9½	10½
159-83-4daa ₂ Test Hole 11			
Glacial Drift:			
	Topsoil, sandy silt loam, black -----	1	1
	Clay, silty and sandy with pebbles, yellowish gray, soft, slightly to moderately cohesive, oxidized (Till) -----	9½	10½

<u>Formation</u>	<u>Material</u>	<u>Thickness (feet)</u>	<u>Depth (feet)</u>
159-83-4dab ₁ Test Hole 12			
Glacial Drift:	Topsoil, sandy loam, black -----	1	1
	Clay, silty and sandy with pebbles, yellowish gray, soft, slightly to moderately cohesive, oxidized (Till)-	9½	10½
159-83-4dab ₂ Test Hole 13			
Glacial Drift:	Topsoil, sandy loam, black -----	1	1
	Clay, silty to sandy with pebbles, yellowish gray, soft, slightly to moderately cohesive, oxidized(Till)-	17	18
	Gravel, fine and medium, sandy, moderately well-sorted, subangular to subrounded -----	2	20
	Clay, silty to sandy with pebbles, olive gray, moderately soft, co- hesive, unoxidized (Till) -----	1	21
159-83-4dba ₁ Test Hole 14			
Glacial Drift:	Topsoil, sandy loam, black -----	1	1
	Gravel, fine and medium, sandy, moderately well-sorted, subangular to subrounded, rusty -----	3	4
	Clay, silty to sandy with pebbles, yellowish gray, soft, slightly to moderately cohesive, oxidized (Till) -----	8	12
	Clay, silty to sandy with pebbles, olive gray, soft, moderately co- hesive, unoxidized (Till) -----	9	21
159-83-4dba ₂ Test Hole 9			
Glacial Drift:	Topsoil, sandy loam, black -----	1	1
	Gravel, fine and medium, sandy, moder- ately well-sorted, subangular to sub- rounded, rusty -----	2	3
	Clay, silty to sandy with pebbles, yellowish gray, soft, moderately co- hesive, oxidized (Till) -----	9	12
	Clay, silty to sandy with pebbles, olive gray, soft, moderately co- hesive, unoxidized (Till) -----	9	21

<u>Formation</u>	<u>Material</u>	<u>Thickness (feet)</u>	<u>Depth (feet)</u>
159-83-4dbb ₁ Test Hole 8			
Glacial Drift:	Topsoil, sandy loam, black -----	1	1
	Gravel, fine and medium, sandy with coarse gravel, moderately sorted, subangular and subrounded, moderately rusty; mostly granitic particles with limestone and shale -----	7	8
	Clay, silty and sandy with pebbles, yellowish gray, soft, moderately soft and cohesive, oxidized(Till)--	2½	10½
159-83-4dbb ₂ Test Hole 7			
Glacial Drift:	Topsoil, sandy silt loam, black ----	1	1
	Clay, silty to sandy with much gravel, yellowish gray to reddish yellow, soft, slightly cohesive, oxidized and rusty, (Till) -----	3	4
	Clay, silty and sandy with pebbles, yellowish gray, soft, slightly to moderately cohesive, oxidized(Till)-	6½	10½
159-83-4ddc Test Hole 5			
Glacial Drift:	Gravel, fine to medium, very sandy, rusty brown, moderately sorted, subangular and subrounded -----	4	4
	Clay, silty and sandy with pebbles, yellowish gray, soft, slightly to moderately cohesive, oxidized(Till)-	8	12
	Clay, silty to sandy with pebbles, olive gray, moderately soft, cohesive, unoxidized (Till) -----	9	21
159-83-5aad Test Hole 4			
Glacial Drift:	Topsoil, sandy loam, black -----	2	2
	Gravel, fine and medium, sandy, moderately well-sorted, subangular and subrounded, rusty -----	4	6
	Sand, fine and medium, interbedded with clay and silt, soft, lignitic, drills easy -----	7	13

159-83-5aad
Test Hole 4 (cont.)

<u>Formation</u>	<u>Material</u>	<u>Thickness</u> (feet)	<u>Depth</u> (feet)
	Clay, silty, olive gray, soft, smooth -----	4	17
	Clay, sandy with pebbles and occasional sand and gravel lenses, olive gray, soft, moderately cohesive, cuttings are quite small (Till)--	49	66
	Gravel, fine to medium, sandy, well-sorted, subangular and subrounded, 'clean' -----	4	70
	Till, as above -----	11	81
	Clay, very sandy with numerous pebbles and frequent cobbles or boulders, also thin lenses of silty clay, sandy clay, loose fine- to medium- grained sand and gravel, olive gray, moderately soft, cohesive (Till); drills tight and slow -----	62	143
	Silt, clayey to sandy, tight, olive gray, soft, moderately cohesive, interbedded -----	8	151
	Clay, silty to very sandy with pebbles, some gravel and occasional rocks, olive gray, moderately soft, cohesive, tightly compacted (Till)--	52	203
	Sand, fine to medium, slightly clayey with coarse sand grains and pebbles, light olive gray to olive gray, slightly cohesive, friable and brittle (Till); drills tight, cuttings are large and square or rectangular in shape -----	22	225
	Till as above, with much bedrock included, mainly olive black, oily, plastic clay and greenish gray sandy clay, occasional rock -----	24	249
Tongue River Formation:	Sand, fine-grained, light greenish gray to greenish gray, well-sorted, subangular, soft, friable, frosted-- electric log	14½	263½

159-83-10cad
Test Hole 16

Glacial Drift:

Topsoil, sandy loam, black -----	1	1
Clay, silty and sandy with pebbles and gravel, yellowish gray, soft, slightly cohesive, oxidized (Till) -----	11	12
Clay, silty and sandy with pebbles, olive gray, moderately soft, cohesive, unoxidized (Till) -----	9	21

<u>Formation</u>	<u>Material</u>	<u>Thickness</u> (feet)	<u>Depth</u> (feet)
159-83-10cda ₁ Test Hole 15			
Glacial Drift:	Topsoil, sandy loam, black -----	1	1
	Gravel, fine and medium, sandy, sorted, rusty -----	1	2
	Clay, silty and sandy with pebbles, yellowish gray, soft, slightly co- hesive, oxidized (Till) -----	10	12
	Clay, silty and sandy with pebbles, olive gray, moderately soft, co- hesive, unoxidized (Till) -----	9	21
159-83-10cda ₂ Test Hole 17			
Glacial Drift:	Topsoil, sandy loam, black -----	1	1
	Gravel, fine and medium, sandy, moderately sorted, subangular and subrounded, very rusty -----	3	4
	Clay, silty and sandy with pebbles, yellowish gray to dusky yellow, soft, cohesive, moderately plastic, oxidized (Till) -----	13	17
	Sand, light olive gray, medium to very coarse, some gravel, well- sorted, generally subrounded; mainly granitic particles with limestone, shale, and lignite; takes water -----	11	28
	Clay, silty and sandy with pebbles, olive gray, moderately soft, cohesive, unoxidized (Till) -----	14	42
159-83-10cda ₃ Test Hole 18			
Glacial Drift:	Topsoil, sandy loam, black -----	1	1
	Gravel, fine and medium, sandy, moder- ately sorted, subrounded, rusty ---	2	3
	Clay, silty and very sandy, soft, slightly cohesive, oxidized(Till)--	7	10
	Clay, silty and sandy with pebbles, dusky yellow to light olive gray, soft, moderately cohesive, partially oxidized (Till) -----	11	21
	Clay, silty and sandy with pebbles, olive gray, soft, cohesive (Till)--	13	34

159-83-10cda₃
Test Hole 18³ (cont.)

<u>Formation</u>	<u>Material</u>	<u>Thickness</u> (feet)	<u>Depth</u> (feet)
	Sand, coarse, well-sorted, subangular to subrounded; caves rapidly, takes water -----	3	37
	Clay, silty to sandy with pebbles, olive gray, moderately soft, cohesive; tight drilling -----	82	119
	Clay, sandy with pebbles and occasional thin sand or gravel lense, olive gray, moderately soft, cohesive; drills tight and uniform -----	92	211
Tongue River Formation:			
	Shale, olive black, moderately soft to slightly hard, massive, cohesive, smooth, very tight, noncalcareous--	21	232
	Sand, fine, greenish gray, soft, friable, frosted ----- electric log	9½	241½

159-83-11ccc
Test Hole 19

Glacial Drift:			
	Topsoil, gravelly loam, dark brown --	1	1
	Sand, clayey, dusky yellow, limey ---	1	2
	Gravel, fine and medium, very sandy, tan, well-sorted, subrounded, clean; takes water -----	7	9
	Clay, silty with sand grains and pebbles, olive gray, moderately soft, cohesive, tight (Till) -----	33	42

160-83-27cdd
Test Hole 3

Glacial Drift:			
	Topsoil, sandy loam, black -----	1	1
	Gravel, fine and medium, sandy, moderately well-sorted, subrounded, rusty, -----	4	5
	Silt, sand, and gravel, interbedded, dusky yellow, sorted in layers ----	5	10
	Clay, sandy and gravelly, moderate olive brown to light olive gray, poorly sorted, partially oxidized (Till) -----	9	19

160-83-27cdd
Test Hole 3 (cont.)

<u>Formation</u>	<u>Material</u>	<u>Thickness (feet)</u>	<u>Depth (feet)</u>
	Clay, silty with sand grains and pebbles, olive gray, soft to moderately soft, cohesive (Till)--	25	44
	Sand, medium, light olive gray, well-sorted, subrounded, quartzose, lignitic -----	5	49
	Clay, silty with sand grains and pebbles, olive gray, moderately soft, cohesive, (Till); easy drilling, very few rocks -----	132	181
	Gravel, fine to coarse, sandy with some silt or clay, poorly-sorted; rough drilling -----	7	188
	Clay, silty to gravelly, olive gray, moderately soft, slightly cohesive to cohesive (Till) -----	6	194
Tongue River Formation:			
	Shale, sandy, olive gray to dark greenish gray, moderately soft, moderately cohesive, laminated ---	9	203
	Sand, fine and medium, dark greenish gray, soft, friable -----	8	211
	Shale, light olive gray, moderately soft, smooth, cohesive -----	5	216
	Sand, fine and medium, dark greenish gray, soft, friable -----	6	222
	Shale, silty, light olive gray to olive gray, moderately soft, smooth, cohesive -----	9	231
	electric log		

REFERENCES

1. Clayton, Lee, 1962, Glacial geology of Logan and McIntosh Counties, North Dakota. North Dakota Geological Survey Bull. 37, 84 p.
2. LaRocque, G. A., Jr., Swenson, H. A., and Greenman, D. W., 1963a, Ground Water in the Crosby-Mohall area, North Dakota; North Dakota Ground-Water Studies No. 54, 57 p.
3. LaRocque, G. A., Jr., Swenson, H. A., and Greenman, D. W., 1963b, Tables of hydrologic data, Crosby-Mohall area, North Dakota; U. S. Geological Survey open-file report, 508 p.
4. Lemke, R. W., 1960, Geology of the Souris River area, North Dakota; U. S. Geological Survey Prof. Paper 325, 133 p.
5. Simpson, H. E., 1929, Geology and ground-water resources of North Dakota, with a discussion of the chemical character of the water by H. B. Riffenburg; U. S. Geological Survey Water-Supply Paper 598, 312 p.
6. U. S. Department of Commerce, 1965, Climatological data (of) North Dakota; U. S. Department of Commerce, Weather Bureau, Annual Summary 1964, v. 73, no. 13, pp. 186-188.