

North Dakota Geological Survey

WILSON M. LAIRD, State Geologist

BULLETIN 42

**North Dakota State
Water Conservation Commission**

MILO W. HOISVEEN, State Engineer

COUNTY GROUND WATER STUDIES 3

**GEOLOGY AND
GROUND WATER RESOURCES**

of Burleigh County, North Dakota

PART II

GROUND WATER BASIC DATA

By

P. G. RANDICH

Geological Survey

United States Department of Interior



Prepared by the United States Geological Survey
in cooperation with the North Dakota Geological Survey and the
North Dakota State Water Conservation Commission

GRAND FORKS, NORTH DAKOTA, 1965

This is one of a series of county reports which will be published cooperatively by the North Dakota Geological Survey and the North Dakota State Water Conservation Commission in three parts. Part I is concerned with geology, Part II, basic data which includes information on existing wells and test drilling, and Part III which will be a study of hydrology in the county. Part III will be published later and will be distributed as soon as possible.

CONTENTS

Introduction-----	<u>Page</u> 1
References-----	273

ILLUSTRATIONS

Figure 1. Map showing physiographic provinces in North Dakota and location of Burleigh County-----	<u>Page</u> 2
2. System of numbering wells and test holes-----	4
3. Map of Burleigh County, North Dakota showing location of wells-----	In pocket
4. Map of Burleigh County, North Dakota showing location of test holes-----	In pocket

TABLES

Table 1. Records of wells and test holes in Burleigh County, North Dakota-----	8
2. Logs of test holes-----	68
3. Chemical analyses of ground water in Burleigh County, North Dakota-----	In pocket
4. Chemical analyses of ground water from glacial drift showing trace or minor constituents	253
5. Water-level measurements in selected wells in Burleigh County, North Dakota-----	254

Introduction

The study of the geology and ground-water resources of Burleigh County, North Dakota has been a cooperative investigation made by the U. S. Geological Survey, the North Dakota State Water Conservation Commission, and the North Dakota Geological Survey. Burleigh County is near the center of the state in the Missouri Plateau physiographic province (figure 1). The results of the study are being published in 3 parts consisting of : Part I, an interpretive report describing the geology, Part II, ground-water basic data, and Part III, an interpretive report describing the ground-water resources. 1/

1/ The classification and nomenclature of the rock units conform to the usage of the North Dakota Geological Survey and also, except for the Fort Union Group and its subdivisions, to that of the U. S. Geological Survey, which regards the Fort Union as a formation. The Fort Union Group as used by the North Dakota Geological Survey includes the Cannonball and Tongue River Formations.

This report contains the basic-data collected during the Burleigh County investigation, and serves as a supplement to the interpretive reports, Parts I and III. The information in this report was collected during the period 1960 to 1964, and consists of: (1) data from an inventory of existing wells, (2) logs of test holes, (3) measured water-levels in key observation wells and (4) chemical analysis of water samples from selected wells. Most of the well-inventory data were collected during the period of study, however, some well data collected before 1960 is also included. Additional analyses of

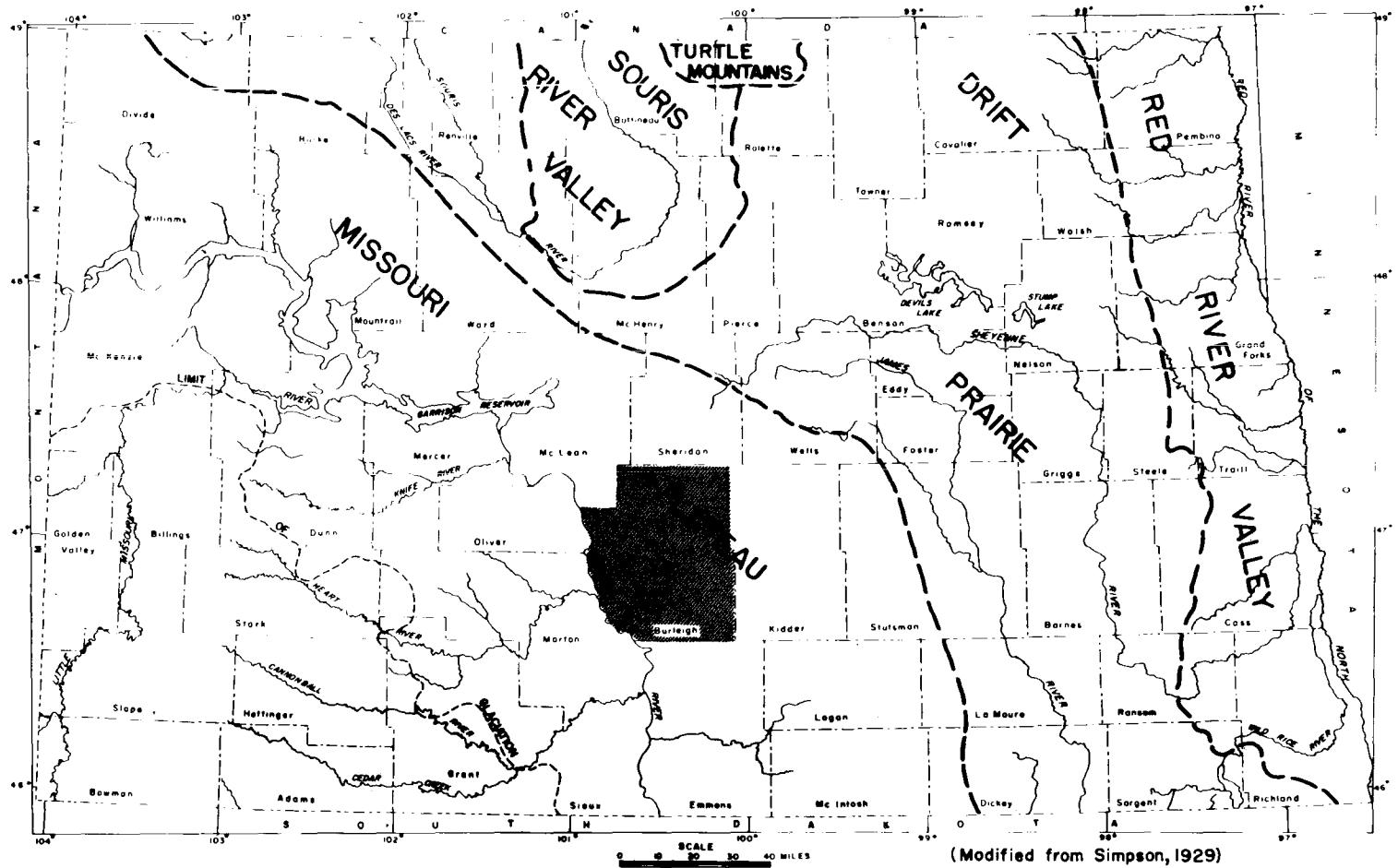

FIGURE 1--MAP SHOWING PHYSIOGRAPHIC PROVINCES IN NORTH DAKOTA AND LOCATION OF BURLEIGH COUNTY.

ground water are published in U. S. Geological Survey Water-Supply Papers 598 and 1428. The logs of test holes are composite logs from a synthesis of drillers logs, sample analysis logs, and in most cases, electric logs. The commercial logs are quoted as they were received from private individuals or concerns. All the 152 test holes were drilled with rotary drilling equipment.

Water levels in key observation wells were measured and reported monthly, except where water-level recorders are installed. An almost continuous water-level record is available for those wells equipped with recorders and water levels are reported as the low water level recorded on every 5th day and the last day of the month. Water samples from selected wells were analyzed for chemical quality by the North Dakota State Laboratories Department, the U. S. Geological Survey, and the North Dakota State Health Department.

The well-numbering system used in this report, illustrated in figure 2, is based upon the location of the well in the federal system of rectangular surveys of the public lands. The first numeral denotes the township north of the base line, the second numeral denotes the range west of the fifth principal meridian, and the third numeral denotes the section in which the well is located. The letters a, b, c, and d designate respectively the northeast, northwest, southwest, and southeast quarter section, quarter-quarter sections, and

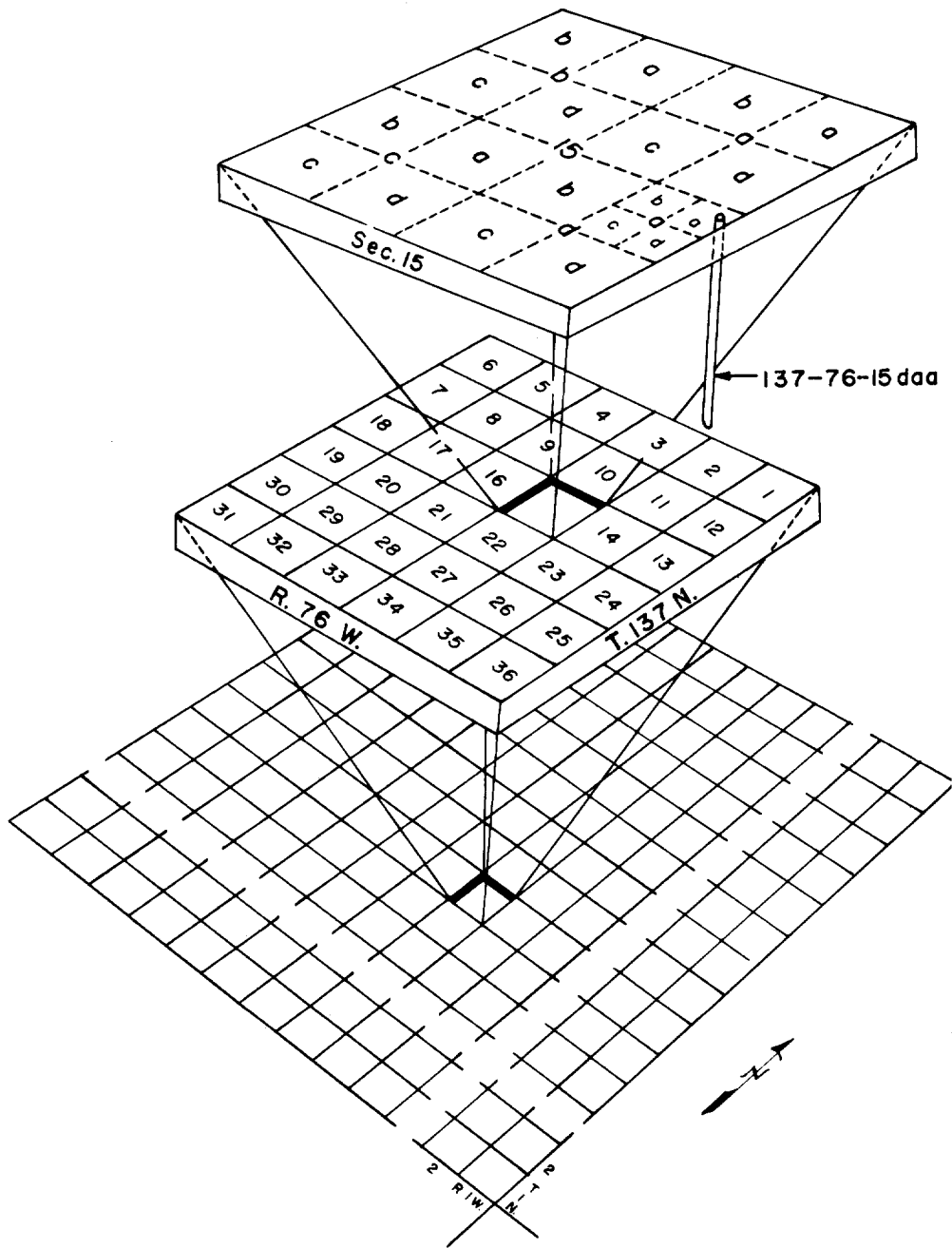

FIGURE 2--SYSTEM OF NUMBERING WELLS AND TEST HOLES.

quarter-quarter-quarter sections (10-acre tracts). Thus a typical well 137-76-15daa is in the NE $\frac{1}{4}$ NE $\frac{1}{4}$ SE $\frac{1}{4}$ sec. 15, T. 137 N., R. 76 W.

The data in this report are useful for predicting subsurface conditions when used in conjunction with the interpretive reports on the geology and ground-water resources in Burleigh County (Parts I and III of this Bulletin). The aquifer depth and thickness, water-level, and quality of water may be estimated for a potential site by examining the records of nearby wells shown in tables 1-5, and figures 2 and 3.

Logs of test holes drilled prior to 1960 are indicated by the 1000 numbering series; those drilled during 1960 by the 1800 numbering series; and those drilled from 1961 thru 1963 by the 1900 or 2000 numbering series. Logs of test holes drilled prior to 1961 were prepared from samples collected at the drilling sites and analyzed after the field season had ended. Logs of test holes drilled after 1961 were analyzed and sample-analysis logs were prepared on the drilling site of each test hole. Sample analysis included color chart comparisons (Goldman, 1928), visual examinations using a binocular microscope, and tests for carbonate. If there was effervescence, when acid contacted the material it is said to be calcareous. Grain-size designations used in all logs refer to the Wentworth size scale (Wentworth, 1922). When the term oxidized is used, it means the material was subjected to the action of waters carrying oxygen, carbon dioxide, etc. The terms angular,

subangular, subrounded, rounded, and well rounded are the terminologies used to indicate various degrees of roundness. Roundness is expressed as the ratio of the average radius of curvature of the maximum inscribed sphere. The term cohesion is used to indicate the tendency for particles of the described material to stick or adhere together. As a descriptive term till indicates an unsorted, unstratified, cohesive, agglomeration of particles ranging from clay to boulder size. Till is also used to indicate the origin of the material.

Modifying terms such as clayey, silty, sandy, and gravelly are textural terms used to indicate that the material described contains an appreciable, but not a dominant amount of the material. The formation name refers to a mappable stratum of reasonably continuous material. Material listed under glacial drift, such as till, is presumed to have been deposited from glacial ice. Bedrock formations were picked by Mr. Jack Kume, N. Dak. Geol. Survey to coincide with the interpretive report on the geology.

In areas where a potential aquifer was penetrated, an observation well was developed from the test hole. These observation wells normally consisted of $1\frac{1}{4}$ inch flexible plastic pipe, slotted the thickness of the sand and/or gravel deposit. In areas where a recorder was installed on the observation well a 4 inch casing was used. From these wells water levels were measured (table 5), and samples collected for chemical analysis (tables 3 and 4).

The author is especially grateful to Schnell Inc., and other drillers who supplied many commercial drillers logs for this report. Thanks are also due to all the farmers engaged in and interested in irrigation, Capital Electric, the Bismarck Chamber of Commerce, and the people of Burleigh County for their help in the collection of these data. Data collected during a reconnaissance study of the Missouri River near Bismarck (Greenman, 1953) was useful in preparing table 1.

TABLE 1.--Records of wells and test holes in Burleigh County, North Dakota

Owner: USGS, United States Geological Survey; USBR, United States Bureau of Reclamation.

Depth of well: Measured depths are given in feet, tenths, and (or) hundredths; reported depths are in feet.

Type of well: Dr, drilled; Du, dug, Dv, driven.

Depth to water: Measured depths are given in feet, tenths, and (or) hundredths; reported depths are in feet.

Use of water or well: D, domestic; Irr, irrigation; N, not used; O, observation of water level; PS, public supply; S, stock; T, test hole.

Aquifer: Gv, gravel, Lig, lignite; Sd, sand; Sh, shale; Ss, sandstone.

Remarks: BR-20, bedrock encountered at 20 feet; C, chemical analysis is shown in table 3; L, log described in table 2; SC-2,360, specific conductance in micromhos at 25° C; Wad, water supply reported to be adequate for present use; Wal, water reported to have alkaline taste; Wh, water reported to be hard; Win, water supply reported to be inadequate for present use; Ws, water reported to be soft; TD-240, total depth drilled.

TABLE 1.--Records of wells and test holes in Burleigh County, North Dakota

Location No.	Owner or name	Depth of well (feet)	Diameter or size (inches)	Type	Date completed	Depth to water below land surface (feet)	Use of water or well	Aquifer	Elevation at land surface	Remarks
(1)	(2)	(3)	(4)	(5)	(6)	(7)	(8)	(9)	(10)	(11)
<u>137-75</u>										
6abb1	W. Backhaus	35	2	Dr	1906	20	S	Sd	Wad, Wh.
6abb2	..dq....	52	2	Dr	1958	30	D	Sd	Wad.
8dda	USGS Test hole 1829	157	5	Dr	1960	T	Gv	1,712	BR-124, L.
10bab	H. Carlisle	90	...	Dr	1937	D,S	Gv	Wad.
12ddc	E. Preszler	90	2	Dr	1938	Flow	D,S	Gv	SC-1,430, Wh.
13bb	Mrs. S. R. Goodings	60	...	Dr	1932	14	D,S	Ss	Wad.
14bb	M. B. Swenson	65	...	Dr	1913	30	D,S	SdDo....
17bbb	USGS Test hole 1828	189	5	Dr	1960	T	Sd & Gv	1,716	BR-168, L.
18acc	E. Porter	35	...	Du	1913	D,S	Clay	Wad.
21bbc	F. A. Lahr	50	...	Dr	1927	D,S	GvDo....
22add	F. Johnson	82	...	Dr	1956	34	D,S	Sd	C, SC-684, Wad.
24cc	Federal Land Bank	90	...	Dr	40	D,S	Clay	Wad.
25dd	R. Arvig	85	...	Dr	D,S	Sd & GvDo....
26cdc	Bank of N. Dak.	90	...	Dr	16	D,S	Sd & GvDo....
27cda	M. Keller	80	2	Dr	1959	30	D,S	Sd & Gv	Wad, 35 grains
28cbb	R. Preszler	20	8	Du	6	D,S	Gv	Wad, Wh.
29ddc	J. Glovich	12.15	48	Du	4.82	D,S	GvDo....
30dd	H. Swanson	90	2	Dr	15	S	SdDo....
31aab	USGS Test hole 2048	45	5	Dr	7-30-62	T	..	1,825.8	BR-30, L.
31bab	J. P. Jenson	187	2	Dr	N	Sd	Wad.

(1)	(2)	(3)	(4)	(5)	(6)	(7)	(8)	(9)	(10)	(11)
<u>137-75 (Cont.)</u>										
32aba	H. Swanson	60	2	Dr	N	Sd	Wad.
32bab1	..do....	90	2	Dr	1931	20	D,S	Sd	Wh, Win.
32bab2	..do....	120	3	Dr	1957	20	D	Sd	SC-1050, Win.
33bb	C. W. Chefman	90	...	Dr	25	D,S	Gv	Wad.
34bb	Bank of N. Dak.	65	...	Dr	25	D,S	SdDo....
34cba	S. Materi	180	4	Dr	40	D,S	Wad, Wh.
<u>137-76</u>										
2bbb	USGS Test hole 2031	165	5	Dr	1962	T	Gv	1,762.6	BR-141, L.
2bbd	E. M. Enockson	80	2	Dr	1960	30	S	Sd	Wad, Wh.
4cab	E. L. Bailey	213	2	Dr	1942	40	D,S	Sd	Wad.
5daa	Schauer	190	2	Dr	70	D,S	Sd	C, SC-1,700, Wad.
6cc	W. S. Hoen Estate	235	2	Dr	1927	D,S	Gv	Wad.
7daa	C. Renz	180	2	Dr	40	D,S	Sd	SC-1,340, Ws.
8cdd	G. Adams	215	5	Dr	1962	T	Sd	C, L.
9add	N. Edwards	196	2	Dr	30	D,S	Sd	SC-1,830, Wad, Ws.
9bbc	USGS Test hole 1825	252	5	Dr	1960	T	Sd & Gv	1,735	BR-126, L.
12cdd	W. Lane	275	2	Dr	1953	75	S	Sd	Wad, Ws.
12ddd	USGS Test hole 1827	73	5	Dr	1960	T	Sd	1,804	BR-47, L.
14aa	B. F. Lane	226	2	Dv	1908	156	D,S	Sh	Wad.
14add	W. Lane	265	2	Dr	1955	100	D,S	Sd	Wad, Ws.
17aaa	USGS Test hole 1826	173	5	Dr	1960	T	Sd & Gv	1,726	L.
17ddd	City of Moffit	170	2	Dr	1955	40	D,S	Sd	Wad, Ws.
18cc	State of N. Dak.	100	2	Dr	1928	50	D,S	Sd	Wad.
18ccd	USGS Test hole 2047	115	5	Dr	7-62	T	Sd	1,821.4	L, BR-5.
18dcc	L. Klepp	40	2	Dr	D,S	Sd	SC-1,110, Wad, Wh.
19caa	Unknown	150	.	Dr	1934	D,S	Sd	SC-1,200, Wad, Ws.
20bbb	H. Feist	90	2	Dr	1955	D,S	Wad.

(1)	(2)	(3)	(4)	(5)	(6)	(7)	(8)	(9)	(10)	(11)
<u>137-76</u> (Cont.)										
21bbc	USGS Test hole 1824	315	5	Dr	1960	T	Ss	1,760	BR-0, L.
22ddd	V. Jensen	160	2	Dr	1931	10	D,S	Sd	Wad.
26aca	U.S. Fish and Wildlife Svc	182	2	Dr	1953	4	D,PS	Sd	C, Reptd solids 850, Wad.
28aad1	G. Fried	80	2	Dr	45	D,S	Wad, Wh.
28dad2	..do....	240	2	Dr	60	S	Sd	Wad, Ws.
29dda	H. Faust	150	2	Dr	1918	100	D,S	Wad, Wh.
30dd	W. E. Nickel	110	2	Dr	1920	D,S	Sd	Wad.
32bb	P. H. McCay (oil test 1)	6,180	13	Dr	1952	1,858	
32bbb	P. H. McCay	305	8	Dr	98.61	S,O	Sd	C, Wad.
32ddc1	..do....	90	2	Dr	60	S	Wad, Wh.
32ddc2	..do....	226	2	Dr	1956	140	D,S	Sd	Wad, Ws
35aaa	USGS Test hole 1937	126	5	Dr	8-31-61	T	Ss	1,719.8	BR-107, L.
36abb	USGS Test hole 1938	199	5	Dr	8-31-61	T	Sd	1,713.9	BR-179, L, PC
36ba	M. Benz	180	2	Dr	D,S	C.
<u>137-77</u>										
1dd	W. I. Mills	175	2	Dr	1920	S	Sd	Wad.
4caal	W. MacDonald	280	2	Dr	30	D	Sd	Wad, Ws.
4caa2	..do....	70	2	Dr	30	S	Sd	Wad.
8bdd	..do....	76	2	Dr	30	S	SdDo....
8ddd	USGS Test hole 1830	493	5	Dr	1960	T	Ss	1,868	BR-59, L.
10aab1	L. Morrison	30	36	Du	1909	12	D,S	Sd	Wh, Win.
10aab2	..do....	170	2.5	Dr	1950	100	D,S	Sd	Wad,
14dda	P. Hoover	100	2	Dr	1957	30	S	Sd	Wad.
14ddd	USGS Test hole 1936	147	5	Dr	8-30-61	T	Ss	1,832.6	BR-7, L.
15ccc	A. Westbrook	20	2	Dr	30	S	Sd	Wad, Wh.

(1)	(2)	(3)	(4)	(5)	(6)	(7)	(8)	(9)	(10)	(11)
<u>137-77</u> (Cont.)										
17aaa	D. Beard	90	2	Dr	1956	12	D,S	Sd	C, Wad, Wh.
20acc1	A. Westbrook	185	2	Dr	60	D,S	Sd	Wad, Ws.
20acc2	..do....	145	2	Dr	50	S	SdDo....
22add	P. Hoover	50	2	Dr	1956	18	D,S	Sd	Wad, Wh.
24cba	E. Magnew	90	2	Dr	30	D,S	SdDo....
24dab	..do....	160	2	Dr	S	SdDo....
28abc	W. Mills	266	2.5	Dr	1953	130	D,S	Sd	C, SC-695, Wad.
30dba	C. Day	268	2	Dr	100	S	Sd	Wad, Ws.
30dbb	..do....	86	2	Dr	30	D,S	Sd	Wad
32cdd	A. Nickolson	300	2	Dr	120	D,S	Sd	Wad, Ws.
34bcc	C. Hoover	159	2	Dr	1959	80	D,S	SdDo....
<u>137-78</u>										
2bb	M. Ives	5	60	Du	1935	3	S	Sd	Wad.
2cc	J. Borner	260	2	Dr	1910	100	D,S	SdDo....
3baa	H. Hogue	315	2	Dr	75	D,S	Sd	SC-1,710, Wad.
4abb1	J. G. Schmidt	275	2	Dr	90	D	Sd	Wad, Ws.
4abb2	..do....	257	2	Dr	1958	77	S	Sd	SC-1,570, Wad.
6add	Federal Land Bank	30	36	Du	1938	4	D,S	Clay	Wad.
7bb	State of N. Dak.	25	..	Du	1934	18	D,S	SdDo....
8bcb	USGS Test hole 2014	216	5	Dr	7-18-62	47.69	T,O	Sd	1,719.5	BR-216, C, L, TD-240.
8cbb	C. Malard	250	2	Dr	1958	80	D,S	Sd	Wad, Ws.
8dbd	A. Stewart	90	2	Dr	D,S	Wad.
9ddd	W. F. Cameron	110	..	Dr	1916	D,S	SdDo....
12bbb	J. Horner	100	2.5	Dr	1920	30	D,S	SsDo....
14caa1	W. Magstadt	203	2	Dr	140	D,S	Sd	Win, Ws.
14caa2	..do....	200	2	Dr	80	D	Sd	Wad, Ws.
17ccc	USGS Test hole 2040	180	5	Dr	7-20-62	T	Sd	1,696.4	BR-169, L.

(1)	(2)	(3)	(4)	(5)	(6)	(7)	(8)	(9)	(10)	(11)
<u>137-78</u> (Cont.)										
19bab	G. Register	60	2	Dr	35	D,S	Sd	Wh.
20baa	W. M. Oder	250	2	Dr	D,S	Sd	C, SC-1,862, Wad.
20dad	W. M. Mc Murrich	300	2	Dr	60	D,S	Sd	Wad, Ws.
21cc	W. Webb	12	2	Dv	1930	5	S	Sd	Wad.
22bcc	A. Anderson	200	2	Dr	1958	100	D,S	Sd	Wad, Ws.
22ccc	USGS Test hole 2013	105	5	Dr	7-18-62	T	..	1,739.4	BR-100, L.
24cdd	O. M. Mills	137	2	Dr	112	D,S	Sd	Wad, Wh.
24dab	A. Giovannoni	148	3	Dr	1922	138	D,S	Lig & SdDo....
26cbb	F. S. Vogel	28	36	Du	1958	8	D,S	SdDo....
26daa	H. Mills	190	2	Dr	1959	170	D,S	Sd	Wad, Ws.
29aba	C. Dietrich	230	2	Dr	120	D,S	Sd	Wad.
30ada1	M. Dietrich	192	2	Dr	D,S	Sd	Wad, Ws.
30ada2	..do....	135	2	Dr	S	SdDo....
33aba	USGS Test hole 2039	185	5	Dr	7-23-62	T,O	Sd	1,711.1	BR-221. C,L, TD-240.
33cc	G. Kratt	150	3	Dr	1909	50	D,S
35abb	J. H. Kershaw	230	2	Dr	1918	200	D,S	Sd	Wad, Ws.
<u>137-79</u>										
2aaa	L. Malard	325	3	Dr	1909	100	D,S	Sd	SC-2,375, Wad
2dcc	D. E. McLean	87	2	Dr	1890	48	D,S	Sd	Wad, Wh.
5dd	S. Robinson Estate	180	2	Dr	1914	20	D,S	Sd	Wad.
6a	J. Claridge	200	2	Dr	D,S	C.
6dad	G. Claridge	80	3	Dr	50	S	Sd	Wad, Wh.
7aa	S. Woodworth	170	2	Dr	30	D,S	Sd	Wad.
7bdc	G. Claridge	120	4	Dr	55	D,S	Sd	Wad, Ws.
8bbb	C. Swenson	70	2	Dr	1952	30	S	Sd	Wh, Win.
8cad	E. Woodworth	256	2	Dr	D,S	Sd	Ws.
8ccd	L. Clark	201	2	Dr	1954	30	D,S	Sd	Wad, Ws.

(1)	(2)	(3)	(4)	(5)	(6)	(7)	(8)	(9)	(10)	(11)
<u>137-79</u> (Cont.)										
10ddc	B. Brown	208	2	Dr	1916	D,S	Sd	Wad, Ws.
11ddd	S. Irvine	100	2.5	Dr	1906	35	D,S	Sd	Wad.
12ccc	A. Irvine	100	2	Dr	1927	30	D,S	SdDo....
14aaa	J. Irvine	100	2	Dr	30	D,S	Sd	SC-750, Wad.
16ab	J. Crawford	83	2	Dr	1927	20	D,S	Sd	Wad.
16cad	W. W. Woodworth	23	1.25	Dr	8	D,S	Sd	Wad, Ws.
18aab	C. D. Kimball	287	2	Dr	1944	200	D,S	SdDo....
26cbb	USGS Test hole 2015	86	5	Dr	7-19-62	14.23	T,O	Sd & Gv	1,724.7	BR-100, C, L, TD-105.
26ccb	A. Maclean	20	1.5	Dv	1928	3	D,S	Sd	Wad.
27dd	G. O'Callaghan, Jr.	95	3	Dr	T	Sd	C, L.
<u>137-80</u>										
1bbd1	C. Swenson	200	2.5	Dr	1951	70	D	Sd	Win, Ws.
1bbd2	..do....	131	2	Dr	1954	65	S	Sd	BR-130, Wad, Wh.
1cbb1	J. Swenson	60	2	Dr	1946	40	S	Lig	Wad.
1cbb2	..do....	165	2	Dr	1958	90	D,S	Sd	C, Wad, Ws.
2aa	..do....	100	2	Dr	85	D,S	Wad.
3aaa1	Annunciation Priory	375	6	Dr	PS	Sd	BR-0, Win, Ws.
3aaa2	..do....	40	8	Dr	13.5	PS	SdDo....
3abb	USGS Test hole 1852	84	5	Dr	1960	T	Ss	1,625	BR-42, L.
3cbb	W. L. Falcner	150	4	Dr	1956	12	D,S	Sd	Wad, Ws.
3dab	USGS Test hole 1851	63	5	Dr	1960	T	Ss	1,620	BR-31, L.
11bda	A. Ashbridge	125	2	Dr	105	D,S	C, Wad.
11dcc	R. Small	180	2.5	Dr	1953	100	D,S	Sd	Wad, Wh, high iron
12bb	C. Ferris	160	2	Dr	1914	140	D,S	Wad.
12ca	A. Boyer	178	2	Dr	1905	160	D,SDo....
13bda	J. Bobidou	197	2	Dr	1926	190	D,S	Sd	C, Wad, Ws.

(1)	(2)	(3)	(4)	(5)	(6)	(7)	(8)	(9)	(10)	(11)
137-80 (Cont.)										
14ad	O. Lighthouse	125	2	Dr	1900	110	D,S	Wad.
24abc	USGS Test hole 1949	126	5	Dr	9-15-61	9.00	T	Sd & Gv	1,627.0	C, L. BR-115.
138-75										
2bb	W. Bros.	300	2	Dr	1910	175	D,S	Sd	Wad,
4cba	K. Fried	302	3	Dr	1957	200	D,S	Sd	C, Wad.
5aa	Federal Land Bank	150	2	Dr	D,S	Wad.
5ddd	USGS Test hole 2046	136.5	5	Dr	7-19-62	T	Sd	1,919.5	BR-122, L.
6bb	C. Syverson	144	2.5	Dr	1907	20	D,S	Wad.
8baa	F. Trautman	225	2	Dr	1949	134	D,S	Sd	Wad.
8cdd	USGS Test hole 2021	120	5	Dr	7-16-62	T	Ss	1,885.3	BR-104, L.
9bcb	USGS Auger hole 18	16	3	Dr	10-18-62	T	..	1,930	L.
10cbb	R. Fried	175	1.5	Dr	1915	84	D,S	Sd	C, Wad, Wh.
16bbb	USGS Auger hole 17	22	3	Dr	10-18-62	T	..	1,900	L.
18aaa1	H. Pederson	160	3	Dr	1959	60	D,S	Sd	Wad, Wh.
18aaa2	..do....	157	2	Dr	1937	60	S	SdDo....
18bbc	Olson Bros.	100	2	Dr	S	Sd	Wad, Wh.
20aaa	USGS Test hole 2025	199.5	5	Dr	7-18-62	T	Gv	1,923.6	BR-173, L.
20dda	F. W. Aichele	280	2	Dr	1946	60	D,S	Wad, Ws.
22ac	A. Whitman	140	2	Dr	1957	S	Wad, Wh.
24bdc	J. Krous	120	2	Dr	1915	60	D,S	Sd	Wad.
27cd	A. Whitman	170	2	Dr	1959	50	S	Sd	Wad, Wh.
29bd	..do....	160	2	Dr	1956	50	SDo....
30ca	..do....	110	2	Dr	1949	50	SDo....
30daa1	..do....	250	2	Dr	1947	40	S	Wad, Ws.
30daa2	..do....	260	3	Dr	1952	40	D,SDo....
32aab	..do....	110	2	Dr	1947	30	S	Wad, Wh.

(1)	(2)	(3)	(4)	(5)	(6)	(7)	(8)	(9)	(10)	(11)
<u>138-76</u>										
4aa	A. Schauer	133	2	Dr	1941	40	S	Sd	Wad, Ws.
6ada1	..do....	133	2	Dr	1952	53	D	SdDo....
6ada2	..do....	175	2	Dr	1936	S	SdDo....
7add	USGS Test hole 1942	147	5	Dr	9-7-61	Flow	T	Sd & Gv	1,732.6	BR-127, C, L.
8abb	USBR drill hole 27	40	3	Dr	1959	8.6	T	Sd	1,755.6	L.
8bab	USBR drill hole 26	35	3	Dr	1959	Flow	T	Gv	1,743.9	..Do....
10cbc1	E. A. Schauer	190	2.5	Dr	1957	45	D,S	Sd	Wad.
10cbc2	..do....	135	2.5	Dr	1940	45	D,S	Sd	Wad.
15bd	..do....	160	2	Dr	1956	60	S	Sd	Wad, Ws.
17dad	M. Bertsch	219	2	Dr	1920	2	D,SDo....
18daa	O. Jerset	240	2	Dr	1951	D,S	Sd	Wad.
19aad	C. Monroe	48	2	Dr	8	D,S	Sd	Wad, Ws.
19a	..do....	70	4	Dr	1961	60	T	Sd	C, L.
19b	..do....	100	4	Dr	1961	T	Sd	L.
19abb	USGS Auger hole 11	107	3	Dr	10-16-62	T	Sd	1,725	L.
20bbb	USGS Auger hole 12	87	3	Dr	10-16-62	T	Gv	1,740	..Do....
20ccc	C. Anderson	14	18	Dr	11	D,S	Sd	Wad.
22ddd	F. Doehle	80	2	Dr	1934	S	Wad, Wh.
24cbb1	G. D. Adams	140	2	Dr	40	D	Sd	C, Wad, Ws.
24cbb2	..do....	35	2	Dr	1925	20	S	Sd & Gv	C, Wad, Wh.
26aaa	USGS Test hole 2032	90	5	Dr	7-27-62	T	Gv	1,777.6	BR-70, L.
26bab1	E. Doehle	140	2	Dr	1957	D	Sd	Wad, Ws.
26bab2	..do....	120	2	Dr	1921	20	SDo....
26db1	C. Sherman	25	18	Du	15	S	Sd & Gv	Wad, Wh.
26db2	..do....	247	2	Dr	1949	37	D,S	Sd	Wad, Ws.

(1)	(2)	(3)	(4)	(5)	(6)	(7)	(8)	(9)	(10)	(11)
<u>138-76 (Cont.)</u>										
28ada1	M. Lewis	60	3	Dr	1954	4	S	Sd	Wad, Ws.
28ada2	..do....	353	3	Dr	1954	6	D,S	Sh	Wad, Wh.
28bcc1	E. A. Schauer	12	36	Du	1898	3	...	Sd	Wad.
28bcc2	..do....	20	2	Dr	1920	1.00	D	Sd	Ws.
30bcc	C. Monroe	173	2	Dr	1943	12	D,S	Clay	Wad, Ws.
31aab	USGS Test hole 2029	180	5	Dr	7-26-62	T	Sd & Gv	1,713.2	BR-164, T.
31bac	C. Monroe	83	2	Dr	1959	10	S	Gv	Wad.
31dbc	..do....	174	2	Dr	1945	8	S	Wad, Ws.
33bbb	USGS Test hole 2022	110	5	Dr	7-16-62	6.22	T,O	Gv	1,726.9	BR-111, C, L, TD-120.
35cbb1	E. M. Enockson	180	2	Dr	1949	50	D	Sd	Wad, Ws.
35cbb2	..do....	140	2	Dr	1950	40	S	Sd	Wad,
36aaa	USGS Auger hole 16	112	3	Dr	10-18-62	T	Sd	L.
<u>138-77</u>										
2abb	USGS Auger hole 7	77	3	Dr	10-12-62	T	Sd & Gv	1,770	BR-65, L.
2daa	L. E. Heaton, Jr.	90	3	Dr	1929	20	D,S	Sd	Wad.
3abb	USGS Auger hole 8	32	3	Dr	10-12-62	T	..	1,725	L.
3ccd	USGS Test hole 1944	189	5	Dr	9-8-61	T	Gv	1,706.5	BR-178, L.
4acc	USBR drill hole 21	100	3	Dr	1958	8.2	T	..	1,704.2	L.
4adc	USBR drill hole 22	70	3	Dr	1958	5.8	T	..	1,706.2	..Do....
4add	USBR drill hole 23	70	3	Dr	1958	11.2	T	Sd	1,705.1	..Do....
5cbb	USBR drill hole 18	35	3	Dr	1959	T	Sd	1,739.9	..Do....
5dab	USBR drill hole 20	60	3	Dr	1958	9.2	T	Sd	1,705.4	..Do....
5dbb	USBR drill hole 19	60	3	Dr	1959	9.9	T	..	1,706.1	..Do....
6ccd	USBR drill hole 15	59.8	3	Dr	1959	13.7	T	Sd	1,706.7	..Do....
6cda	USBR drill hole 16	60	3	Dr	1959	16.2	T	..	1,709.3	..Do....
6daa	USGS Test hole 1945	84	5	Dr	9-11-61	T	Sd & Gv	1,734.8	BR-64, L.
6dbd	USBR drill hole 17	60	3	Dr	1959	11.8	T	..	1,710.5	L.
7cbb	USGS Test hole 1946	220	5	Dr	9-11-61	T	Gv	1,702.6	BR-184, L.

(1)	(2)	(3)	(4)	(5)	(6)	(7)	(8)	(9)	(10)	(11)
138-77 (Cont.)										
7daa	Northwest Mortgage Co.	125	2	Dr	1919	30	D	Sd	Wad.
9bdb	USGS Test hole 1831	231	5	Dr	1960	T	Sd	1,700	BR-153, L.
10d	W. McDonald	160	4	Dr	1961	T	Gv	L.
10dca	..do....	160	4	Dr	1961	T	GvDo....
10dcd	..do....	198	4	Dr	1961	T	GvDo....
11aaa	USGS Test hole 1943	126	5	Dr	9-8-61	T	Sd	1,742.6	BR-90, L.
12bdal	R. Heaton	65	2	Dr	1951	50	D	Sd	Wad, Wh.
12bda2	..do....	80	2	Dr	1960	51	S	Sd	Wh.
13aaa	USGS Test hole 2028	120	5	Dr	7-27-62	T	Gv	1,722.7	BR-100, L.
13cab	W. G. Fischer	100	2	Dr	1946	14	D,S	Sd	Wad.
14add	Test hole 1940	231	5	Dr	9-6-61	T	Gv	1,721.0	L.
14ccc	USGS Test hole 1941	136	5	Dr	9-7-61	T	Sd & Gv	1,716.9	BR-126, L.
14dbb	Bank of N. Dak.	130	..	Dr	1915	12	D,S	Sd	Wad.
15aaa	USGS Test hole 2023	210	5	Dr	7-17-62	12.63	T,O	Gv	1,720.6	BR-213, C, L. TD-225.
15bbb	USGS Auger hole 13	112	3	Dr	10-17-62	T	Sd	1,706	L.
15cca	W. Anderson	150	4	Dr	1961	T	SdDo....
15dcb	..do....	138.4	17	Dr	6-61	13.19	Irr, O	Gv	1,717.6	C, L, Wad.
17cc	Northwest Mortgage Co.	112	2	Dr	1930	35	N	Sd	Wad.
18cc	Federal Land Bank	120	2	Dr	1927	N	Sd	Win.
19bb	C. Monroe	100	2	Dr	1915	40	N	Sd	Wad.
20aaa	USGS Test hole 1867	231	5	Dr	1960	T	Gv	1,700	BR-171, L.
20add	G. R. Krause	150	2	Dr	1939	20	D,S	Sd	Wad.
21cbcl	W. Anderson	240	2	Dr	40	D	Sd	Wad, Ws.
21cbc2	..do....	90	2	Dr	40	S	Sd	Wad, Wh.
22aad	USGS Test hole 1955	126	5	Dr	9-22-61	11.38	T,O	Gv	1,720.0	BR-122, L, C.

(1)	(2)	(3)	(4)	(5)	(6)	(7)	(8)	(9)	(10)	(11)
138-77 (Cont.)										
22bb	W. Anderson	140	2	Dr	1918	25	D	Sd	Wad.
22bdd	..do....	130	4	Dr	1961	T	Sd	L.
22cac	..do....	130	4	Dr	1961	T	GvDo....
22dda	USGS Auger hole 15	110	3	Dr	10-18-62	T	Sd	1,724	..Do....
23aac	USGS Test hole 1979	130	5	Dr	5-31-62	26.95	T,0	Sd & Gv	1,736.4	BR-122, L.
23ddb1	R. Baeth	105	17	Dr	9-13-61	37.30	Irr	Sd & Gv	1,738.9	C, L, Wad.
23ddb2	Baeth screen test hole	90	5	Dr	5-18-62	37.73	T,0	Sd & Gv	1,738.0	L.
23ddb3	Baeth pumping test observation well	107	5	Dr	10-30-61	23.37	T,0	Sd & Gv	1,730.5	..Do....
24abb	M. Burke	85	3	Dr	22	D,S	Gv	Wad.
24bbb	USGS Auger hole 14	112	3	Dr	10-17-62	T	Gv	1,722	L.
24caa1	M. Burke	16.5	4	Dr	1958	4	S	Sd	Wad.
24caa2	..do....	107.4	4	Dr	1961	27.37	S	Gv	1,735.3	..Do....
24ccc	USGS Test hole 1939	168	5	Dr	9-1-61	T	Gv	1,740.4	BR-160, L.
24dcc	USGS Auger hole 9	112	3	Dr	10-15-62	T	Sd	1,729	L.
24ddd	USGS Auger hole 10	102	3	Dr	10-15-62	T	Sd	1,718	..Do....
25a	W. McDonald	100	4	Dr	1961	T	GvDo....
25aa	C. A. Anderson	200	2	Dr	1918	20	S	Sd	Wad.
25bbd1	G. Adams	78.2	17	Dr	6-61	39.72	Irr,0	Gv	1,741.3	C, Wh.
25bbd2	Adams screen test hole	80	5	Dr	5-31-62	37.63	T	Gv	1,741	L.
25d	W. McDonald	60	7	Dr	1961	T	GvDo....
25daa	..do....	56	4	Dr	6-6-61	26.38	T,N	Gv	1,738.2	L, Wad.
26adc	USGS Test hole 1954	63	5	Dr	9-20-61	31.74	T,0	Gv	1,738.4	BR-74, C, L, TD-78.75.
26bba	R. Baeth	150	2	Dr	1918	15	D,S	Sd	Wad.
26daa	G. Adams	60	2	Dr	1909	30	D,S	SdDo....
26daa	USGS Test hole 1869	231	5	Dr	1960	T	Gv	1,698	BR-179, L.

(1)	(2)	(3)	(4)	(5)	(6)	(7)	(8)	(9)	(10)	(11)
<u>138-77 (Cont.)</u>										
27aaa	W. Anderson	250	2	Dr	1937	15	S	Sd	Wad.
27dab	..do....	140	2	Dr	60	S	SdDo....
28ddd	J. W. Dean	108	4	Dr	1914	60	D,S	SdDo....
30add	A. Stark	114	2	Dr	1953	72	D,S	Sd	Wad, Ws.
31dd	J. W. Dean	30	12	Dr	1930	8	S	Sd	Wad.
32daa	USGS Test hole 1868	210	5	Dr	1960	T	Sd	1,813	BR-22, L.
32dd	State Land Dept.	81	2.5	Dr	1920	20	N	Sd	Wad.
34add	A. Edwards	137	2	Dr	70	D,S	Sd	Wad, Ws.
35bbb	USGS Test hole 2030	60	5	Dr	7-26-62	T	Sd	1,769.0	BR-40, L.
35bca	A. Edwards	100	2	Dr	50	S	Sd	Wad.
36dd	C. A. Anderson	100	2	Dr	1925	20	S	SdDo....
<u>138-78</u>										
1abb	USGS Test hole 1952	210	5	Dr	9-18-61	T	Sd & Gv	1,702.5	BR-198, L.
1ddd	USBR drill hole 14	60	3	Dr	1959	9.2	T	Sd	1,703.0	L.
2cdd	USBR drill hole 12	24.7	3	Dr	1959	T	Sd	1,727.2	..Do....
3bb	C. Schmitz	60	2	Dr	30	S	Sd	Wad.
5aaa	T. A. Thach	142	2.5	Dr	1948	D,S	Sd	Wad, Wh.
6bad	N. A. Nissen	180	1.5	Dr	1941	40	D,S	Sd	Wad, Ws.
9aad	C. Schmitz	138	2	Dr	1918	70	D,S	Sd	Wad.
9dd	G. W. Venum	115	4	Dr	1905	25	D,S	LigDo....
10dcd	M. Evans	190	2	Dr	D,S	SdDo....
11aa	Northwest Mortgage Co.	115	3	Dr	1906	35	S	SdDo....
14bda	W. Johner	90	2	Dr	D,S	SdDo....
14dcb1	P. C. Ehnen	190	2	Dr	60	S	SdDo....
14dcb2	..do....	228	2	Dr	1953	35	D	Sd	Wad, Ws.
15bcc	H. L. McLean	190	2	Dr	70	D,S	Sd	C, Wad, Ws.
15dd	F. Johnson	90	2	Dr	30	D,S	Sd	Wad.

(1)	(2)	(3)	(4)	(5)	(6)	(7)	(8)	(9)	(10)	(11)
<u>138-78</u> (Cont.)										
16cbc	D. W. McLean	200	2.5	Dr	1950	D,S	Sd	Wad, Ws.
16daa	..do....	150	2	Dr	S	SdDo....
17dac	T. Dorman	80	2	Dr	1959	40	D,S	Sd	Wad, Wh.
19abb	USGS Test hole 1948	84	5	Dr	9-15-61	T	Sd	1,758.9	BR-60, L.
21ccc	USGS Test hole 2041	105	5	Dr	7-24-62	T	..	1,739.4	BR-83, L.
22caa	M. Knoll	120	2	Dr	1910	D,S	Sd	Wad.
22daa	..do....	125	2	Dr	1948	60	S	Sd	Wad, Ws.
23aaa	USGS Test hole 1947	178	5	Dr	9-14-61	T	Sd & Gv	1,697.5	BR-173, L.
23bbb	USGS Test hole 1870	231	5	Dr	1960	T	Sd & Gv	1,695	BR-132, L.
26ddd	E. Dutton, Sr.	92	2	Dr	1910	40	D,S	lig	Wad.
27ccd	USGS Test hole 2042	210	5	Dr	7-23-62	42.35	T,O	Sd & Gv	1,723.7	BR-220, C, L, TD-230.
27dad	I. Funston	280	2	Dr	1946	20	D,S	C, Wad.
28ccd1	C. K. Boyd	133	2	Dr	1934	18	D,S	Sd	Wad.
28ccd2	..do....	136	2	Dr	24	D	SdDo....
30add	L. Dappler	180	2	Dr	1958	65	D,S	Sd	Wad, Ws.
31aaa	J. Welch	85	2	Dr	1915	25	D,S	Sd	Wad.
31dd	L. Dappler	86	2	Dr	1926	25	D,S	SdDo....
32aaa	R. M. Welch	138	2	Dr	1925	25	D,S	SdDo....
32bb	J. O. Welch	76	2	Dr	1906	20	D,S	SdDo....
32daa	USGS Test hole 2012	185	5	Dr	7-17-62	48.22	T,O	Sd & Gv	1,727.9	BR-198, C, L, TD-210.
34bbc	C. K. Boyd	262	2	Dr	30	D,S	Sd	Wad, Ws.
35aaa	E. Dutton, Jr.	210	2	Dr	60	D,S	SdDo....
35cc	E. Olson	154	2	Dr	40	D,S	Sd	Wad.
<u>138-79</u>										
2aaa	USGS Test hole 2053	75	5	Dr	8-2-62	T	Sd	1,702.9	BR-62, L.
2abb	F. Miller	258	2	Dr	1954	50	D,S	Sd	Wad, Ws.
2cdb	W. Layee	95	2	Dr	1957	25	D,S	Sd	Wad, Wh.
3cac	USGS Auger hole 5	107	3	Dr	8-11-62	T	Sd	1,700	L.
4ccd	T. D. Sullivan	120	2	Dr	1935	3	Wad.

(1)	(2)	(3)	(4)	(5)	(6)	(7)	(8)	(9)	(10)	(11)
<u>138-79</u> (Cont.)										
4ddd	W. Field	140	2	Dr	1920	30	D	Sd	Win. .
5dd	H. Tatley	150	4	Dr	1935	Wad.
6ccc	Mrs. W. Erlenmeyer	89	2	Dr	1938	3Do....
6ddd	P. Rannick	20	..	Du	1934	12	...	SdDo....
8aaa	USGS Test hole 1860	158	5	Dr	1960	T	..	1,651	L, BR-116
9abb	USGS Test hole 1861	105	5	Dr	1960	Flow	T	Gv	1,655	C, L.
10aab	W. Inko	158	4	Dr	1919	40	D	Gv	Wad.
10cbb	C. O. Nelson	170	4	Dr	1926	60	D,SDo....
12bbc	A. J. Braun	108	2	Dr	1953	30	D,S	SdDo....
14bbb	C. O. Nelson	115	4	Dr	1902	40Do....
16cdd	L. F. McCurdy	175	2	Dr	1917	75	SDo....
17cd	E. Taix	270	2	Dr	1913	100	S	Sd	Wad, Ws.
18cca1	H. Tatley	100	2	Dr	D,S	C.
18cca2	..do....	180	2	Dr	D,SDo....
19dcd	USGS Auger hole 4	17	3	Dr	8-11-62	T	..	1,740	L.
20ccc	USGS Auger hole 3	7	3	Dr	8-11-62	T	..	1,754	..Do....
24caa	R. Brown	70	2	Dr	D,S	Wad.
26ccd	W. S. Malard	126	2	Dr	65	D,S	Sd	SC-1,465, Wad.
30bb	H. Swanson	24	4	Dv	1938	18	...	Sd	Wad.
34ccc	A. Robidion	250	2	Dr	1925	SdDo....
<u>138-80</u>										
1dcc	USGS Auger hole 1	97	3	Dr	8-11-62	T	Sd & Gv	1,640	L.
1dda	H. Hammond	140	4	Dr	1950	25	D	Gv	Wad.
2bbc	USGS Test hole 2058	84	5	Dr	9-7-62	T	Sd	1,677.9	BR-47, L.
2ccc	USGS Test hole 2057	142	5	Dr	9-5-62	21.13	T,O	Sd & Gv	1,668.5	BR-170, C, L, TD-174.
4acc	Armours Creamery	390	4	Dr	D,PS	Sd	C.

(1)	(2)	(3)	(4)	(5)	(6)	(7)	(8)	(9)	(10)	(11)
<u>138-80</u>										
4acd	Yegen Dairy	470	4	Dr	D,S	Sd	C.
8ddd	USGS Test hole 1863	168	5	Dr	1960	T	Gv	1,635	BR-114, L.
9bcd	P. Wachter	105	17	Dr	9-60	20.71	Irr	Gv	1,643.3	C, L.
11aa	R. Small	144	2	Dr	1926	130	D,S	Wad.
11ddd	USGS Test hole 1858	84	5	Dr	1960	T	..	1,665	BR-31, L.
12bbc	USGS Test hole 1859	115	5	Dr	1960	T	Gv	1,664	L.
13bbb	A. W. Cook	163	2	Dr	1950	40	D,S	Gv	Wad, Ws.
13cbb	C. P. Yegen	171	5	Dr	1961	T	L.
13ccb	..do....	90	4	Dr	1961	T	SdDo....
13ccc	USGS Test hole 1857	493	5	Dr	1960	T	Sd	1,641	BR-84, L.
13cdd	C. P. Yegen	90	4	Dr	1961	T	Gv	BR-89, L.
13cd1	..do....	380	6	Dr	Flow	D,S	Sd	Wad, Ws.
13cd2	..do....	120	3	Dr	70	D,S	Gv	Wad, Wh.
15bbd	Fort Lincoln Nursery	129	17	Dr	1958	43.68	Irr	Gv	1,657.8	C, L.
15cba	Fort Lincoln Nursery	164	17	Dr	1952	46.11	Irr	Gv	1,663.9	C, L, PC.
15cdd	USGS Test hole 1956	168	5	Dr	9-28-61	38.17	T,0	Gv	1,658.4	BR-156, L, C.
17aad	R. L. Melville	32	1.75	Dv	10	S	Gv	Wad.
17aca	USGS Auger hole 22	72	3	Dr	10-22-62	17.86	T,0	Gv	1,737.2	L.
17acb1	J. Peterson	90	17	Dr	1961	19.10	Irr,0	Gv	1,638.1	C, L.
17acb2	USGS Auger hole 21	67	3	Dr	10-22-62	18.10	T,0	Sd & Gv	1,637.5	L.
19add	F. Borbage	58	3	Dr	1956	15	D,S	Gv	Wad, Wh.
20aab	C. S. Huber	40	1.25	Dr	1938	20	D,S	Wad.
21ccc	USGS Test hole 1854	147	5	Dr	1960	T	Gv	1,631	L, BR-124
22abd	USGS Test hole 1958	157	5	Dr	10-4-61	44.65	T,0	Gv	1,662.0	BR-152, L.
22aac	D. McDonald	131	17	Dr	10-60	45.64	Irr,0	Gv	1,660.9	C, L.

(1)	(2)	(3)	(4)	(5)	(6)	(7)	(8)	(9)	(10)	(11)
138-80	(Cont.)									
22abd2	USGS Test hole 1957	157.5	5	Dr	10-4-61	41.82	T,O	Gv	1,659.4	BR-152, L, C.
22baa	D. McDonald	260	1.5	Dr	1937	40	D,S	Gv	Wad.
22bbc	..do....	130	5	Dr	1962	T	Gv	L.
23aab	D. Solberg	100	4	Dr	1961	T	SdDo....
23aba	..do....	100	4	Dr	1961	T	SdDo....
23bdc	..do....	110	15	Dr	8-61	37.43	Irr,O	Gv	1,656.9	BR-110, C, L, C.
23ccc	USGS Test hole 1855	273	5	Dr	1960	T	Gv	1,651	ER-98, L.
24aba	C. P. Yegen	120	3	Dr	70	D,S	Gv	Wad, Wh.
24bcb	M. Bachmeier	97	2.5	Dr	1959	30	D	Gv	Wad.
24cac1	C. P. Yegen	80	17	Dr	9-60	13.48	Irr,O	Gv	1,633.7	C, L, TD-85
24cac2	..do....	90	4	Dr	1962	T	Sd	L.
24cac3	..do....	90	4	Dr	1961	T	SdDo....
24cbd	..do....	91	4	Dr	1961	T	GvDo....
24cca	..do....	90	4	Dr	1961	T	SdDo....
24daa	USGS Auger hole 2	27	3	Dr	10-11-62	T	Sd	1,680	..Do....
24dac	C. P. Yegen	150	4	Dr	1961	T	SdDo....
24ddc	..do....	211	4	Dr	1961	T	SdDo....
25bab	..do....	100	17	Dr	14.03	Irr,O	Gv	L.
25bba	..do....	81	4	Dr	1962	T	SdDo....
25cda	..do....	60	4	Dr	1961	T	SdDo....
25dac	..do....	155	6	Dr	1963	34	Irr,O	Sd	C,L.
25dbd	..do....	80	4	Dr	1963	T	Sd	L.
25dda1	..do....	201	4	Dr	1961	T	SdDo....
25dda2	..do....	180	4	Dr	1963	24	T	SdDo....
25dda3	..do....	186	36	Dr	1963	T	Sd & GvDo....

(1)	(2)	(3)	(4)	(5)	(6)	(7)	(8)	(9)	(10)	(11)
<u>138-80</u>	(Cont.)									
25ddb	C. P. Yegen	160	4	Dr	1963	T	Sd	L.
25ddd	..do....	195	4	Dr	1963	40	T	SdDo....
26abb	E. Taix	186	2	Dr	1955	13	D,S	Sd	Wad, Ws.
26bc	W. B. Falconer	210	2.5	Dr	1955	60	D,S	Sd	Wad.
27cdc	USGS Test hole 1929	52.5	5	Dr	8-24-61	T	Sd	1,627.9	L, BR-41
27cdd	F. Aune	55	2	Dr	1958	D	Gv	Wad, Wn.
27dad	A. Falconer	105	2	Dr	1905	90	D,S	Sd	Wh, Win.
27dda	USGS Test hole 1856	147	5	Dr	1960	T	..	1,630	BR-43, L.
28bad	G. Briese	60	2	Dr	1958	D,S	Gv	Wad, Wh.
29ada	W. R. Mills	25	1.25	Dr	1940	13	D	SdDo....
29bab	USGS Test hole 1013	70	5	Dr	1958	T	Gv	L.
29bad	N. Dak. Prison farm	93	17	Dr	1961	20	Irr	Gv	C, L, Wad, TD-110.
29bbb1	USGS Test hole 1012	130	5	Dr	1958	T	Gv	BR-125, L.
29bbb2	USGS Test hole 1853	147	5	Dr	1960	T	Gv	1,639	BR-111, L.
34dbc	J. Robidou	31	1.25	Dr	16	D,S	Sd	Wad, Wh.
35bb	S. Francis	215	2	Dr	1936	200	D,S	Sd	Wad.
<u>139-75</u>										
3ddd	USGS Test hole 1977	284	5	Dr	1-23-62	T	..	1,820	BR-74, L.
4bdc1	Berg Bros.	120	1.5	Dr	1959	D	Gv	Wad, Ws.
4bdc2	..do....	125	1.5	Dr	1950	D,S	GvDo....
4bdc3	..do....	130	...	Dr	1948	SDo....
4bdc4	..do....	100	...	Dr	1956	SDo....
4dd	R. Quale	12	48 x 48	Du	1959	10	S	Sd	Wad, Wh.
6ccc	R. Sorenson	80	3	Dr	15	SDo....
7dvd	A.A. Fischer	100	2	Dr	50	D,S	Sd	Wad, Ws, Temp. -46°F
7ddc	..do....	100	2	Dr	1930	50	D,S	Wad, Ws.
8dba	J. Reiderer	125	2.5	Dr	N	Sd	Ws.

(1)	(2)	(3)	(4)	(5)	(6)	(7)	(8)	(9)	(10)	(11)
<u>139-75</u> (Cont.)										
9daa1	R. Quale	78	3	Dr	1959	20	D,S	Sd	C, Wad.
9daa2	..do....	119	2	Dr	1959	15	D	Sd	Wad, Ws.
9daa3	..do....	70	16	Dr	1910	18	S	Sd & Gv	Wad.
10dcc	D. Pfennig	35	..	Dr	D,S	GvDo....
11cd	A. H. Wanner	60	2	Dr	15	D,S	Sd	Wad, Wh.
12ccd	D. Nelson	124	2	Dr	1961	65	D,S	Sd & GvDo....
13cca	J. Taszarek	135	2.5	Dr	1957	18	D,S	Sd	C, Wad.
14ddc	H. Rinder	...	4	Dr	35	D,S
15ccd	G. C. Tank	100	2	Dr	50	D,S	Sd	Wad, Ws.
16cdd	J. Marquart	150	2.5	Dr	S	SdDo....
17ada	O. Reiderer	120	2.5	Dr	1920	D,S	SdDo....
18ccd	O. Auck	150	2	Dr	1943	90	D,S	Sd	Wad.
19caa	USGS Test hole 2049-D	52.5	5	Dr	3-22-63	T,O	Gv	1,815.3	BR-46, C, I.
22abb	R. H. Halsne	140	2	Dr	1956	25	S	Sd	Wad, Ws.
22ccb	USGS Test hole 2020	60	5	Dr	7-16-62	T	..	1,871.1	BR-57, L.
24aac1	R. Olson	135	2	Dr	1955	111	D	Sd	Wad, Ws.
24aac2	..do....	80	2	Dr	75	S	Sd	Wad.
26bcb	R. Schumaker	122	2	Dr	1959	85	D,S	Sd	Wad, Wh.
27ccb	H. Brushwood	204	2	Dr	1958	30	D,S	SsDo....
28aba1	O. Morast	150	4	Dr	1948	D	Wad.
28aba2	..do....	70	4	Dr	SDo....
32cda	Christianson Estate	170	2.5	Dr	1910	120	D,S	SdDo....
33cb	A. Geist	150	2	Dr	1944	35	D,S	Wad, Wh. Temp. 44.5°F.
<u>139-76</u>										
3bdd	E. Renschler	124	2.5	Dr	1944	S	Wad.
4abb	F. Envick	220	2	Dr	1910	140	D,SDo....
5ada	R. Brown	230	2.5	Dr	1948	30	D,S	Sd	Wad, Ws.
6acc	J. Brown	160	2	Dr	35	S	SdDo....
6ddc	..do....	160	2	Dr	35	S	SdDo....

(1)	(2)	(3)	(4)	(5)	(6)	(7)	(8)	(9)	(10)	(11)
139-76 (Cont.)										
8add1	W. Johnson	220	2.5	Dr	D	Sd	Wad, Ws.
8add2	..do....	130	2.5	Dr	SDo....
9bcb	N. L. Funston	189	2.5	Dr	1956	180	D,S	Sd	Wad, Wh.
11bbd1	E. Renschler	170	2.5	Dr	1955	D
11bbd2	..do....	150	2.5	Dr	50	S	Wh.
12aad	R. Sorenson	100	2	Dr	22	D,S	Sd	Wad, Wh.
14bbc	J. Lang	175	2.5	Dr	D,S	Sd	Wad, Ws.
14dda	H. Olson	150	2	Dr	1946	90	S	Sd	C, Wad.
15aac	J. Lang	180	2.5	Dr	S	Sd	Wad, Ws.
16bbd	E. Lang	320	2.5	Dr	1956	D	Ws.
19bcb	M. Envik	240	2	Dr	1958	D,S	Sd	Wad, Ws.
20abb	USGS Test hole 2017	50	5	Dr	7-11-62	T	..	1,961.4	BR-42, L.
20cdd1	T. A. Lang	300	2.5	Dr	180	D	Sd	Wad, Ws.
20cdd2	..do....	180	2.5	Dr	S	Wad.
22dc	P. Biegler	300	3	Dr	1954	40	D,S	Sd	Wad, Ws.
23aab	W. Dickenson	140	3	Dr	1948	90	D,S	SdDo....
23cbb1	J. Lang	180	2	Dr	1949	130	S	SdDo....
23cbb2	..do....	205	2	Dr	1958	D	SdDo....
24bba1	H. Olson	150	2	Dr	1941	90	S	Sd	Wad, Ws, Temp. -43°F.
24bba2	..do....	150	2	Dr	1953	140	D	Sd	Wad, Ws.
26dda	USGS Test hole 2034	42	5	Dr	7-30-62	T	Gv	1,810.2	BR-5, L.
27cdc	D. Goetz	140	2	Dr	1946	30	D,S	Sd	Wad, Ws.
28cb1	B. Nelson	155	2	Dr	1958	90	D	SdDo....
28cb2	..do....	160	2	Dr	1958	50	S	SdDo....
3lcd	A. Scharer	58	2	Dr	1956	40	S	Sd	Wad, Wh.

(1)	(2)	(3)	(4)	(5)	(6)	(7)	(8)	(9)	(10)	(11)
<u>139-76 (Cont.)</u>										
34aba	S. Fletcher	93	2	Dr	S	Sd	C, Wad.
35aad	P. Biegler	180	2	Dr	1954	50	D	Sd	Wad, Ws.
35baa	..do....	190	2	Dr	1942	S	SdDo....
36aa	..do....	500	6	Dr	1952	78.85	N	Sd
36dad	..do....	160	2	Dr	S	SdDo....
<u>139-77</u>										
1bbb	USGS Test hole 2055	63	5	Dr	7-30-62	T	..	1,809.2	BR-51, L.
2bcc	R. J. Boyd	90	2	Dr	30	D,S	Sd	Wad, Wh.
6aaa	USGS Test hole 1934	94	5	Dr	8-29-61	T	Sd	1,739.8	BR-68, L.
6aac	P. P. Bliss	100	2.5	Dr	25	D,S	Sd	Wad, Ws.
8cbc	USGS Test hole 1953	115	5	Dr	9-20-61	T	Sd	1,739.8	BR-104, L.
10ccd	B. Zahn	88	2	Dr	1935	60	D,S	Sd	C, Wad, Wh.
14aad	A. Vetter	60	..	Dr	1889	28	D,S	Sd	Wad, Wh.
15ccc	USGS Test hole 2016	45	5	Dr	7-11-62	T	..	1,753	BR-30.5, L.
20ccc	USGS Test hole 2036	225	5	Dr	7-25-62	T	Sd	1,705.0	BR-209.5, L.
20ddc1	W. Knutson	127	2	Dr	D	Sd	Wad.
20ddc2	..do....	150	2	Dr	1960	60	S	Sd	Wad, Ws.
21aa	H. Hubesthal	100	2	Dr	1913	45	D,S	Wad.
22cc	T. T. Hughes	224	2	Dr	1918	100	D,SDo....
25dcc	E. Fiest	170	2	Dr	D,S	Sd	Wad.
26cdb	E. Shira	225	2	Dr	1951	30	S	Sd	Wad, Ws.
27bcc	G. Geiger	121	2	Dr	1955	48	S	SdDo....
27ccc	N. Erickson	112	2	Dr	1907	D,S	SdDo....
28cc1	McKenzie School	200	2	Dr	6	D,S	SdDo....
28cc2	Methodist Ch. ch	200	2	Dr	1951	6	D	SdDo....
28cc3	J. Maier	300	2	Dr	Flow	D	Sd	C, Wad, Ws.

(1)	(2)	(3)	(4)	(5)	(6)	(7)	(8)	(9)	(10)	(11)
<u>139-77 (Cont.)</u>										
28daa1	G. Geiger	336	2	Dr	1952	48	D	Sd	Wad, Ws.
28daa2	..do....	104	2	Dr	1954	80	S	Sd	Wad, Wh.
29dad	W. Knutson	50	3	Dr	1910	4	SDo....
30bbc	M. Victor	90	2	Dr	1959	10	D,SDo....
32aaa	USGS Test hole 1866	252	5	Dr	1960	T	Gv	1,708	BR-200, L.
34bbb	USGS Test hole 2035	45	5	Dr	7-26-62	T	Sd	1,752.8	BR-27, L.
35bba	E. Shira	200	2	Dr	30	D,S	Sd	Wad, Ws.
36abb	E. Fiest	280	3	Dr	1945	S	SdDo....
<u>139-78</u>										
2aa	J. Agnew	80	2	Dr	1942	S	Sd	Ws.
2cd	W. Wachal	160	2	Dr	1917	21	D,S	Sd	Wad, Wh.
3aad1	J. Agnew	50	36	Dr	1928	12.85	N	Sd	Wad.
3aad2	..do....	70	2	Dr	1944	30	D,S	Sd	Wad, Ws, Temp.-46°F.
4ad	M. D. Agnew	125	2	Dr	30	D,S	Sd	Wad, Wh.
4cdc1	R. McCormick	120	2	Dr	S	Sd	Wad.
4cdc2	..do....	80	2	Dr	1950	D	Sd	Wad, Wh.
4dcd	M. Agnew	115	2	Dr	1956	50	S	SdDo....
8aaa	USGS Test hole 1950	105	5	Dr	9-18-61	T	..	1,716.6	BR-92, L.
10dcb	M. Agnew	180	2	Dr	40	S	Sd	Wad, Wh.
10ddd	..do....	80	2	Dr	20	D,S	SdDo....
11aaa	USGS Test hole 1951	63	5	Dr	9-18-61	T	..	1,715.6	BR-35, L.
11abb	USGS Test hole 1932	63	5	Dr	8-25-61	T	..	1,746.8	BR-34, L.
12acd	D. & C. Bohrer	190	2	Dr	1960	S	Sd	Wad, Wh.
13caa	L. O. Salter	80	2.5	Dr	1946	S	Gv	Wad.

(1)	(2)	(3)	(4)	(5)	(6)	(7)	(8)	(9)	(10)	(11)
139-78	(Cont.)									
14acc	D. & C. Bohrer	300	2	Dr	S	Sd	Wad, Ws.
14cdd	..do....	95	4	Dr	30	D,S	Gv	Wad, Wh.
15aac	L. O. Salter	60	24	Du	1907	D,S	SdDo....
15bcc1	..do....	200	2	Dr	1950	60	D	Sd	Wad, Ws.
15bcc2	..do....	75	2	Dr	1943	S	Sd	Wad, Wh.
16ccc	USGS Test hole 1865	210	5	Dr	1960	T	Gv	1,682	BR-159, L.
17daa1	A. Neugebauer	50	2	Dr	37	D,S	Sd	Wad, Wh.
17daa2	..do....	340	2	Dr	1951	63	D	Sd	Wad, Ws.
18bd	R. Boone	70	2	Dr	40	D,S	Sd	Wad, Wh.
18db	..do....	140	2	Dr	S	Sd	Wad, Ws.
19ddd	USGS Test hole 2011	135	5	Dr	7-11-62	T	Sd	1,717.5	BR-90, L.
20ad1	J. C. Pfeiffer	200	2	Dr	1950	30	D,S	Sd	Wad, Ws.
20ad2	..do....	90	2	Dr	25	S	Sd	Wad, Wh.
21dbc	L. Salter	140	2	Dr	1950	30	D,S	GvDo....
22bb	T. C. Casey	195	4	Dr	1960	T	Gv	L.
22bd	..do....	180	4	Dr	1960	T	GvDo....
22cc	..do....	180	4	Dr	1960	T	SdDo....
22cd	..do....	216	4	Dr	1960	T	SdDo....
23cda	USGS Test hole 2010	265	5	Dr	7-9-62	T	Sd & Gv	1,718.5	BR-260, L.
24baa	D. & C. Bohrer	100	2	Dr	D,S	Wad, Wh.
24cdc	USGS Test hole 1933	231	5	Dr	8-25-61	T	Gv	1,699.5	BR-211, L.
27cbb	USGS Test hole 2037	255	5	Dr	7-24-62	T,O	Gv	1,713.3	BR-245, C, L.
28bd	J. Schmidt	125	2	Dr	50	D,S	Sd	Wad, Ws.
29dda1	E. W. Klipstein	90	2	Dr	1936	30	S	Sd	Wad, Wh.
29dda2	..do....	400	2	Dr	15	D,S	Ss	Wad, Ws.

(1)	(2)	(3)	(4)	(5)	(6)	(7)	(8)	(9)	(10)	(11)
<u>139-78</u> (Cont.)										
30cdd	USGS Test hole 2054	45	5	Dr	8-2-62	20	T	..	1,883.1	BR-17, L.
31baa	E. W. Klipstein	90	2	Dr	20	D,S	Sd	Wad, Wh.
31ddb	USGS Test hole 1864	472	5	Dr	1960	T	Ss	1,680	BR-147, L.
32aaa	E. W. Klipstein	400	2	Dr	15	D,S	Ss	Wad, Ws.
33bb	A. C. Dance	100	2	Dr	D	Wad.
33bbc	USGS Auger hole 6	57	3	Dr	1962	T	Sd	1,690	L.
34cc	C. D. King	137	2	Dr	D,S	Wad.
<u>139-79</u>										
1acc	W. Trygg	160	2.5	Dr	1936	S	Win.
2ccc	A. Ashbridge	165	2	Dr	1902	D,S	Wad.
4dd	G. Anderson	170	2.5	Dr	106	SDo....
5ccd	O. Swanson	235	2.5	Dr	1924	135	SDo....
8bb	F. H. Trygg	150	2.5	Dr	1904	75	D,SDo....
10bb	G. Anderson	89	2	Dr	1935	70	D,SDo....
12bbc	H. Galet	390	2.5	Dr	1922	190	SDo....
18dad	Magnolia Petroleum Co.	80	5	Dr	1944	T	L.
18ddc	G. Gabel	80	4	Dr	1902	60	D,S	Wad.
19aab	Magnolia Petroleum Co.	80	5	Dr	1944	T	L.
20ddd	Mrs. Stimitz	180	2.5	Dr	1916	10	S	Wad.
22aaa	Magnolia Petroleum Co.	80	5	Dr	1944	T	L.
22acc	J. Gabel	57	48	Du	1939	S	Wad.
24bcc	USGS Test hole 1930	42	5	Dr	8-24-61	T	Gv	1,677.2	BR-26, L.
25dd	J. P. French	50	3	Dr	1916	10	S	Wad.
28bb	J. Gabel	65	2.5	Dr	SDo....
29adc	A. Gabel	150	2.5	Dr	1918	SDo....
29dba	J. Gavel, Jr.	160	2.5	Dr	1916	D,SDo....
32ccb	V. Brown	108	2	Dr	D,SDo....
33aad	USBR drill hole 5	34.6	3	Dr	1959	T	..	1,663.7	L.

(1)	(2)	(3)	(4)	(5)	(6)	(7)	(8)	(9)	(10)	(11)
<u>139-79 (Cont.)</u>										
35aad1	USGS Test hole 1862	147	5	Dr	1960	T	Gv	1,660	L.
35aad2	USGS Test hole 1862 A	152	5	Dr	1960	T	Gv	1,660	..Do....
35ca	USBR drill hole 8	30	3	Dr	1958	6.7	T	Sd	1,662.3	..Do....
35cba	USBR drill hole 7	49.8	3	Dr	1958	2.4	T	Sd	1,663.1	..Do....
36bcc	I. Reict	50	2.5	Dr	1920	D,S	Wad.
<u>139-80</u>										
2aa	W. E. Sellens	307	2	Dr	1930	D,S	Clay & GvDo....
2bba	Magnolia Petroleum Co.	90	5	Dr	1944	T	L.
2ccd	J. W. Paysens	165	2	Dr	24	D,S	Wad.
3abb	USGS Test hole 1981	55	5	Dr	6-18-62	T	Sd	1,844.3	BR-39, L.
4bab	Magnolia Petroleum Co.	80	5	Dr	1944	T	L.
4ccc	Federal Land Bank	260	2	Dr	S	Wad.
6bd	Cook	90	2	Dr	S	Clay	C, Wad.
8abb	L. Bunker	260	2	Dr	1920	D,S	Wad.
8cc	O. Felck	73	2	Dr	1925	15	S	GvDo....
8ddd	M. Haider	158	2	Dr	1928	50	D,S	SdDo....
9ada	Magnolia Petroleum Co.	80	5	Dr	1944	T	L.
10aaa1	H. Breen	56	4	Du	1890	52	D,S	Sd	Wad.
10aaa2	Magnolia Petroleum Co.	80	5	Dr	1944	T	L.
12dbd	Flanagan Estate	175	2	Dr	25	S	Sd	Wad.
13dca	C. McGarvey	345	2	Dr	1916	15	D,SDo....
16ccb	C. F. Sturtz	225	3	Dr	1923	75	D,S	SdDo....
20dab	G. W. Jennings	180	2	Dr	1919	D,S	SdDo....
21dd	C. Chrisk	275	2	Dr	1920	D,S	SdDo....
22abb	Magnolia Petroleum Co.	80	5	Dr	1944	T	L.
22ddd	USGS Test hole 2059	21	5	Dr	9-7-62	T	Gv	1,700.8	BR-12, L.

(1)	(2)	(3)	(4)	(5)	(6)	(7)	(8)	(9)	(10)	(11)
<u>139-80</u> (Cont.)										
24bcc	S. Turnbow	230	2	Dr	1918	50	D,S	Wad.
26bcc	T. Yeller	140	2	Dr	1936	D,SDo....
28aad	Magnolia Petroleum Co.	80	5	Dr	1944	T	L.
29bcb	B. Robertson	240	2	Dr	D,S	Sd	C, Wad.
29cac	A. H. Christianson	33	2	Dr	D,S	SdDo....
30aa	B. Ward	150	2	Dr	S	Sd	Wad.
30bd	J. W. Tyler	140	2	Dr	D,S	SdDo....
33bdb	C. Leonhard	240	2	Dr	D	Sd	C, Wad.
35cc	R. Breen	317	2	Dr	1925	45	D,S	Wad.
35ddd	USGS Test hole 2060	84	5	Dr	9-7-62	T	..	1,660.2	BR-70, L.
36bcd	USBR drill hole 2	65	3	Dr	1958	11.5	T,O	Sd	1,669.7	L.
<u>139-81</u>										
1ab	R. Jiran	60	2	Dr	S	SdDo....
1bcc	W. A. Sellens	125	2	Dr	D,S	Sd	Wad.
2aa	R. Jiran	160	2	Dr	D,S	SdDo....
2cbb	USGS Test hole 1980	110	5	Dr	6-18-62	T	Sd	1,643.5	BR-106, L.
3dc	R. Johnson	28	1.5	Dr	9.69	D	Sd	Wad.
3dd	..do....	35	1.25	Dv	D	SdDo....
1ladc	R. Ward	104	7	Dr	1960	15	Irr,O	Sd	C, Wad.
1lcd	G. E. Shipp	30	1.25	Dv	1935	12	D,S	Sd	Wad.
12bdc	M. G. Ward	220	2	Dr	1933	90	D,S	SdDo....
14aba	J. McClusky	22	1.25	Dv	11.21	D	SdDo....
14dc	P. Garsa	20	1.25	Dv	D	SdDo....
23aa	R. Windgreen	20	1.25	Dv	D	SdDo....
24da	F. M. Roberts	250	2	Dr	D	SdDo....
25aa	R. Moetvedt	75	2	Dr	D	SdDo....

(1)	(2)	(3)	(4)	(5)	(6)	(7)	(8)	(9)	(10)	(11)
<u>140-75</u>										
1aaa	USGS Test hole 2049 A	179	5	Dr	3-20-63	52.30	T,O	Gv	1,917.2	BR-179, C, L, TD-189.
2bbb1	M. E. Christenson	146	3	Dr	1960	74	S	Ss	Wad, Wh.
2bbb2	..do....	128	2	Dr	116	D,S	SdDo....
4dca	A. Dronen	135	2	Dr	1944	50	S	SdDo....
6dbd	G. Vik	160	2	Dr	1946	100	D,S	Sd	Wad, Ws.
7cc	A. Seibel	90	2	Dr	1959	15	S	Sd	Wad, Wh.
8ad	W. Malsam	115	2.5	Dr	1938	60	D,S	Sd	Wad, Wh, temp.-45° F.
8bc	A. M. Hansen	84	2	Dr	30	D,S	Sd	Wad, Ws.
9aa	A. Dronen	320	7	Dr	1952	25	N	Sd	BR-reported 220, Ws.
9dac	..do....	135	2	Dr	1946	50	S	Sd	Wad, Wh.
10bcc1	Mrs. N. Dronen	100	2	Dr	1952	D	SdDo....
10bcc2	..do....	135	2	Dr	1905	S	SdDo....
10dcc	A. Dronen	60	2	Dr	1910	25	D,S	SdDo....
11bdd	..do....	267	3	Dr	1960	120	S	Sd	Wad, Ws.
11cd	..do....	180	2	Dr	1958	60	S	SdDo....
12ccc	Federal Land Bank	67	22	Dr	1907	60	D	Win.
12cdd	USGS Test hole 2049	167	5	Dr	7-30-60	13.46	T,O	Gv	1,862.7	BR-184, C, L, TD-189.
15ddd	A. J. Wanner	80	2	Dr	20	S	Sd	Wad, Wh.
16dcb	P. Pasley	150	2.5	Dr	1940	S	SdDo....
17dd	L. Kluksdahl	186	2	Dr	1952	25	D,S	Sd	Wad, Ws.
18dd	..do....	100	..	Dr	1958	25	S	SdDo....
20aaa	P. Pasley	60	2.5	Du	20	D,S	Sd	Wh, Win.
20bc	J. Kluksdahl	110	2	Dr	1952	15	D,S	Sd	Wad, Ws.
20cdd	R. Fichter	160	2	Dr	1945	12	D,S	SdDo....
21ddd	USGS Test hole 2003	90	5	Dr	7-12-62	T	..	1,880.6	BR-66, L.

(1)	(2)	(3)	(4)	(5)	(6)	(7)	(8)	(9)	(10)	(11)
<u>140-75</u>	(Cont.)									
22ccc	Sam Vik	60	2	Dr	1910	35	D,S	Sd	Wad, Wh.
23dcd	E. Carlson	130	3	Dr	1958	16	S	Sd	Wad, Ws.
24ccd	R. Rnschler	90	2	Dr	16	D,S	Sd	Wad, Wh.
24daa	R. Shoepf	90	3	Dr	1920	8	D,S	GvDo....
24ddd	USGS Test hole 2049 B	132	5	Dr	3-21-63	4.66	T,O	Gv	1,836.7	BR 136, L, TD-147.
25aba	H. Espeset1	100	2	Dr	1918	30	D,S	Wad.
26adal	E. Carlson	125	2	Dr	16	S	lig	Wh.
26ada2	..do....	220	2	Dr	1959	25	D,S	Sd	Wad.
26bdc	O. Knudson	60	3	Dr	20	D,S	Sd	Wad, Wh.
27acc	J. Kocovrek	135	2	Dr	1958	50	S	SdDo....
27dcc	..do....	130	2	Dr	1914	60	D,S	Sd	C, Wad, Wh.
28aaa	S. Vik	100	2	Dr	1956	40	S	Sd	Wad, Wh.
28dda	M. Kluksdahl	125	2	Dr	1922	20	D,S	Sd	Wad, Wal, Wh.
29cdd	A. Schumaker	66	2	Dr	1961	37	S	Sd	Wad, Wh.
30bad	C. A. Belile	63	2.5	Dr	20	D,S	SdDo....
31add1	J. Pfennig	60	2	Dr	35	D,S	SdDo....
31add2	..do....	125	2	Dr	35	S	SdDo....
32dcc	USGS Test hole 2049 C	73.5	5	Dr	1963	T	..	1,832.6	BR-64, L.
33daa	R. Olauson	154	2.5	Dr	1917	20	D,S	Sd	Wad, Ws.
34bdc	A. Schumaker	42	2	Dr	1957	20	D	Sd	Wad, Wh.
35add	USGS Test hole 2033	75	5	Dr	1963	T	Sd	1,820.7	BR-58, L.
<u>140-76</u>										
2cd	R. Johnson	120	2	Dr	18	D,S	Sd	Wad, Ws.
4aa	F. Gershaw	70	2	Dr	1934	13	D,S	Sd	Wad.
8ccc	A. Pidarson	120	2	Dr	D,S	Sd	Wad, Ws.
10ccc	L. Clark	140	2	Dr	1944	25	D,S	Sd	Wad, Wal, Ws.
12cdd	A. Seibel	90	2	Dr	25	D,S	Sd	Wad, Wh.

(1)	(2)	(3)	(4)	(5)	(6)	(7)	(8)	(9)	(10)	(11)
<u>140-76</u> (Cont.)										
14ad	A. Seibel	80	2	Dr	1933	40	D,S	Sd	Wad, Wh.
14daa	USGS Test hole 2019	120	5	Dr	7-12-62	T	..	1,858.5	BR-106, L.
17bab	A. Miller	165	2	Dr	1934	20	D,S	Sd	Wad, Wh.
18bbc	USGS Test hole 1935	94	5	Dr	8-29-61	T	Gv	1,816	BR-23, L.
19acc	Patterson Ranch	120	2	Dr	1961	30	S	Sd	Wad, Ws.
20dd	E. Smith	250	2	Dr	1944	160	D	SdDo....
21bcd	..do....	160	2	Dr	1915	65	S	SdDo....
24cd1	D. B. Harmon	190	2	Dr	1960	60	D	SdDo....
24cd2	..do....	160	2	Dr	60	S	SdDo....
25ccc	USGS Test hole 2018	70	5	Dr	7-12-62	Flow	T,O	Sd	1,835.4	BR-83, C, L, TD-90.
28bbb	J. Kerger	240	2	Dr	65	D,S	Sd	Wad, Ws.
28dbd	E. Elness	115	2	Dr	1944	30	D,S	SdDo....
29aad	J. Kerger	160	2	Dr	45	S	Sd	Wad.
30baa1	E. Renschler	50	12	Dr	1919	40	S	Sd	Wad, Wh.
30baa2	..do....	145	2	Dr	1955	25	D,S	Sd	Wad, Ws.
32aaa	USGS Test hole 2026	210	5	Dr	7-27-62	T	Sd	1,893.1	BR-48, L.
33aab	C. Elness	265	2	Dr	1947	18	D,S	Sd	Wad, Ws.
34cc	J. Clark	100	2	Dr	1935	55	S	Sd	Wad.
36bbb	R. Sorenson	154	2	Dr	20	S	Sd	Wad, Ws.
<u>140-77</u>										
2aa	Patterson Ranch	80	2	Dr	1910	35	S	SdDo....
3bb	Dumeland oil test 1	6,860	13	Dr	1952	T	..	1,970
6dd	P. Davidson	125	2	Dr	1929	D,S	Sd	Wad.
7cc1	W. M. Conner	75	2	Dr	10	D,S	Sd	Wad, Ws.
7cc2	..do....	130	2	Dr	1952	D,S	SdDo....

(1)	(2)	(3)	(4)	(5)	(6)	(7)	(8)	(9)	(10)	(11)
<u>140-77</u> (Cont.)										
8aa	R. Kohler	282	3	Dr	1918	80	S	Sd	Wad, Ws.
8dbd	P. L. McNeill	62	2	Dr	1960	7	S	Sd	Wad, Wn.
10dbb	..do....	150	2	Dr	1909	40	D,S	Sd	Wad, Wal, Wh.
11dbb	Patterson Ranch	190	2	Dr	1956	80	S	Sd	Wad, Ws.
12ccd	..do....	90	3	Dr	45	D,S	SdDo....
13bab	..do....	90	2	Dr	45	D,S	Sd	C, Wad, Ws.
14bad	..do....	120	2	Dr	1906	80	S	Sd	Wad, Wh.
14ccd	O. G. Darwver	160	2	Dr	1925	75	D,S	Sd	Wad, Ws.
14dca	..do....	135	2	Dr	1959	30	S	SdDo....
16dbb	Patterson Ranch	90	2	Dr	25	S	Sd	Wad, Wh.
22cb1	E. Bloomquist	280	2	Dr	60	D,S	Sd	Wad, Wal, Ws.
22cb2	..do....	90	2	Dr	1948	8	D,S	Gv	Wad, Wh.
24add	A. Roth	148	2	Dr	1939	16	D,S	Sd	Wad, Ws.
25aaa	..do....	124	2	Dr	1953	4	S	SdDo....
26ca	M. Roth	90	2	Dr	1936	Flow	S	Sd	Wad, Wh.
26cad	..do....	140	2	Dr	18	D,S	Sd	Wad, Ws.
29bb	D. & M. Holding Co.	120	2	Dr	1915	80	D,S	Wad.
34cc	H. Larson	90	2	Dr	1920	D,S	SdDo....
35dbd	Dr. M. W. Roan	120 +	2	Dr	1958	30	S	Sd	Wad, Ws.
36acc	Patterson Ranch	90	2	Dr	15	S	SdDo....
<u>140-78</u>										
2bc	H. McCormick	65	2	Dr	28	D,S	Sd	C, Wad, Ws.
4aa	M. Bourgois	250	2.5	Dr	1909	S	Sd	Wad.
6cda	C. Ryberg	125	2	Dr	1925	30	D,S	Sd	Wad, Ws.
8aa	G. Hendrickson	300	2	Dr	1905	159	S	Wad.
10ac	A. Miller	100	2	Dr	1938	50	D,S	Ss	Wad, Ws.

(1)	(2)	(3)	(4)	(5)	(6)	(7)	(8)	(9)	(10)	(11)
<u>140-78</u> (Cont.)										
11ddc1	W. Kershah	160	2	Dr	1960	6	D	Sd	Wad, Ws.
11ddc2	..do....	175	2	Dr	1915	Flow	S	SdDo....
14aaa	USGS Test hole 2008	30	5	Dr	7-5-62	T	Gv	1,771.5	BR-19.5, L.
16dbb	P. McCormick	220	2	Dr	1921	12	S	Sd	Wad, Wal, Ws.
18bb	E. Ryberg	175	2	Dr	1900	30	Wad.
20bbb	I. Sherman	200	2	Dr	100'	D,S	Sd	Wad, Ws.
20cbb	A. Hogue	80	2	Dr	1940	D,S	SdDo....
22aac	P. McCormick	180	2	Dr	1936	25	D,S	Sd	Wad, Wal, Ws.
26bb	F. D. Owen	90	2	Dr	40	D,S	SdDo....
30ca1	E. McCormick	180	2	Dr	1924	10	S	Sd	Wad, Ws.
30ca2	..do....	42	2	Dr	1925	10	D	Sd & Gv	Wh, Win.
32ddd	USGS Test hole 1931	63	5	Dr	8-25-61	T	..	1,767.9	BR-42, L.
34acd	USGS Test hole 2027	60	5	Dr	7-25-62	T	..	1,751.8	BR-36, L.
34bb	A. Shower	130	2	Dr	1926	25	...	Sd	Wad.
36bba	USGS Test hole 2009	86	5	Dr	7-5-62	12.52	T,0	Sd & Gv	1,742.4	BR-86, C, L, TD-105.
<u>140-79</u>										
1cb	C. E. Cunningham	29	36	Du	1932	7	D,S	Sd	Wad, Wh.
2dab	..do....	318	2	Dr	198	S	Sd	Wad, Ws.
4aa	V. Couch	250	2	Dr	1904	35	D,S	Sd	Wad.
5bb	T. Burkhardt	28	6	Dr	1934	15	D,S	Sd & GvDo....
5cbc	E. Bourgeas	274	2	Dr	1923	D,S	SdDo....
6aba	J. Parsons	28	36	Du	1916	23	D,S	GvDo....
6bcc	J. G. Thysell	300	2	Dr	1928	275	D,S	SdDo....
7ccd	Federal Land Bank	225	2	Dr	1929	200	D,S	SdDo....
10bdb	C. Martinson	95	2	Dr	85	D,S	Sd	Win.
10cbb	USGS Test hole 2038	115	5	Dr	7-25-62	T	Ss	2,129.6	BR-1, L.

(1)	(2)	(3)	(4)	(5)	(6)	(7)	(8)	(9)	(10)	(11)
<u>140-79</u>	(Cont.)									
11dd	C. Martinson	15	24	Du	1934	13	S	Gv	Wad.
14bbc	C. Johnson	300	2	Dr	1900	280	D,S	SdDo....
14cc	A. W. Johnson	290	2	Dr	1924	270	D,SDo....
14dd	P. Ryberg	225	2	Dr	1902	200	D,S	C, Wad.
16aa	H. Erickson	112	2	Dr	1917	60	S	Wad.
16dd	State of N. Dak.	135	2	Dr	1916	80	D,S	SdDo....
19cc	F. G. Grambs	280	2	Dr	1929	240	S	SdDo....
20cc	G. Clooten	200	2	Dr	1918	144	D,S	SdDo....
20dbd	Martinson Estate	260	2	Dr	1920	200	D,S	SsDo....
22bb	H. P. Solberg	230	2	Dr	1910	100	D,SDo....
22ccd	H. Solberg	192	2	Dr	1910	100	D,S	SdDo....
23bb	Paul Ryberg oil test 1	7,230	10	Dr	1954	T	..	2,007
26aca	A. H. Solberg	125	2	Dr	1903	65	D,S	SdDo....
26dd	C. A. Johnson	35	2	Dr	1910	20	D,S	Wad.
27aa	R. Erickson	54	2	Dr	1933	25	SDo....
28aa	D. Ryberg	27	2	Dr	1900	20	D,S	Sd	Win.
28bb	M. Flanagan	82	2	Dr	1900	70	D,S	Sd	Wad.
30ccc1	I. Houge	180	2	Dr	1917	170	D,S	Sd	Win.
30ccc2	..do....	330	2	Dr	S	Sd	C, Wad.
32bb	B. Holte	210	2	Dr	1929	175	D,S	Wad.
34abd	A. L. Small	160	2	Dr	1917	140	D,SDo....
34cc	Erickson Bros.	130	2	Dr	1905	30	D,S	SdDo....
35cc	Campbell Estate	68	2	Dr	1934	38	SDo....
<u>140-80</u>										
1ccc	G. Werble	25	48	Du	1917	20	D,SDo....
2dbb	M. Bourgois	235	2	Dr	1912	200	D,SDo....
4bac	E. Lenihan	280	2	Dr	1900	D,SDo....
6bda	E. Morris	170	2	Dr	1900	D,S	Win.
7cbb	R. Schonert	17.4	24	Du	1939	4.83	S	Sd	Wad, Wh.

(1)	(2)	(3)	(4)	(5)	(6)	(7)	(8)	(9)	(10)	(11)
140-80 (Cont.)										
8bbd	H. Andahl	135	2	Dr	D,S	Sd	SC-679, Wad, T.-49°F.
8ccv	R. Andahl	80	2	Dr	D,S	Sd	SC-710, Wad, T.-50°F.
11cc	C. Schulz	320	2	Dr	1924	300	D,S	Wad.
12bb	E. Baumgart	12	48	Du	1928	9	D,SDo....
12ddd	A. Borkhart	228	2	Dr	1939	200	D,SDo....
17bbb	R. Andahl	365	2	Dr	1957	D,S	Sd	C, SC-750, Wad, T.-50°F.
17bdd	..do....	400	2	Dr	1959	S	Sd	Wad.
18bac	G. Satler	170	2	Dr	1903	100	D,SDo....
18cc	E. Kleven oil test 1	7,970	11	Dr	1952	T	..	1,910
19bba	W. Paul	325	2	Dr	1908	200	D,SDo....
19dd	L. Blatner	220	..	Dr	1920	D,SDo....
22aad	H. Schonert	160	2	Dr	1917	100	D,SDo....
23bbc	R. Hague	280	2	Dr	1917	200	D,SDo....
24aab	E. J. Barker	275	2	Dr	1912	200	D,SDo....
24ccb	J. B. Raock	225	2	Dr	1922	D,S	ClayDo....
25ccc	W. Miller	250	2	Dr	1908	200	D,S	ClayDo....
26aab	C. Spitzer	22	30	Dr	1910	10	D,SDo....
26ddd	A. Bertsch	80	2	Dr	1900	60	D,S	Win!
27aab	E. Flanagan	180	..	Dr	1916	D,SDo....
29cbb	USGS Test hole 1982	20	5	Dr	6-19-62	T	Gv	1,703.9	BR-14, L.
30ccd	J. Mahoney	135	2	Dr	1914	100	D,S	Wad.
30dda	G. Kulish	70	4	Dr	D,S	Sd	Wad, T.-48°F.
33dad	L. Ward	180	2	Dr	1915	100	D	Wad.
35ccc	W. H. Morris	200	2	Dr	1908	150Do....
36dcc	W. Clooten	180	2	Dr	1917	100	D,SDo....

(1)	(2)	(3)	(4)	(5)	(6)	(7)	(8)	(9)	(10)	(11)
<u>140-81</u>										
1ddc	P. J. Jahner	107	2	Dr	1919	95	D,S	Sd	SC-790, Wad, T.-49°F.
2bbc	H. Schaefer	9.5	48	Du	6.24	N	Sd
2dcb	..do....	300	2.5	Dr	1939	D,S	Sd	Wad, T.-47°F.
4ac	E. Bourgeois	280	2	Dr	D,S	Sd	Wad.
5aa	N. Pederson	30	2	Dr	1929	14	D,S	Sd	C,Wad.
5aaa	USGS Test hole 1983	90	5	Dr	6-19-62	7.35	T,O	Sd & Gv	1,644.6	C, L. TD-105.
9bac	C. L. Sanders	376	2	Dr	1941	Flow	D,S	Ss	C, SC-2,720, Wad.
9ddc	..do....	280	2	Dr	1947	40	S	Sd	Wad, T.-49°F.
13bcc	J. Flannigan	160	2	Dv	1909	150	D,S	Sd	Wad.
14acd	G. Hage	130	2	Dr	1913	115	S	SdDo....
21dd	W. Koch	20	1.25	Dv	D	SdDo....
22ca	E. Bourgeois	120	2	Dr	D	SdDo....
23aa	N. Worst	216	2	Dr	1909	210	D,S	SdDo....
24bb	E. Bourgeois	280	2	Dr	1925	70	D,S	SdDo....
25cc	G. O. Hagen	184	2	Dr	1920	180	D,SDo....
35bac	E. Bourgeois	135	2	Dr	1933	132	D,S	SdDo....
35dca	L. W. Sperry	118	2	Dr	1913	115	D,S	ClayDo....
<u>141-75</u>										
2bb	M. Heidt	168	2	Dr	1929	75	D,S	Sd	Wad, Ws.
2dbc	..Do....	280	2.5	Dr	1949	95	D,S	SdDo....
4dd	R. Heidt	120	1.25	Dr	1909	100	D,S	Sd	Wad, Wh.
5bb	E. Koski	160	3	Dr	1961	110	S	SdDo....
8ccc	C. M. Bjerke	67	2.25	Dr	1909	57	D,S	Sd	Wad.
10aab	P. I. Eness	124	2.25	Dr	1918	25	D,S	SdDo....
10bdc	R. Heidt	80	1.125	Dr	1908	40	D,S	SdDo....
10daa	E. Hinkel	40	18	Du	1934	30	D,S	SdDo....
11bcb	G. F. Regler	140	2.5	Dr	1916	15	D,S	SdDo....
20aa	A. Kangor	160	2	Dr	1920	80	D,S	SdDo....

(1)	(2)	(3)	(4)	(5)	(6)	(7)	(8)	(9)	(10)	(11)
<u>141-75</u> (Cont.)										
21dbd1	H. O. Arneson	140	4	Dr	1913	80	S	Sd	C, Wad, Wh.
21dbd2	..do....	300	4	Dr	1948	120	D,S	Sd	Wad, Ws.
21ddd	USGS Test hole 2002	105	5	Dr	6-29-62	T	Sd	1,952.6	BR-93, L.
25bcc	E. Heidt	180	2	Dr	70	D,S	Gv	Wad, Wh.
26ddc	..do....	114	2	Dr	1961	40	S	GvDo....
27cdd	J. O. Rise	140	4	Dr	1906	60	D,S	Sd	Wad.
28aaa	S. Lien	135	2	Dr	1908	80	D,S	SdDo....
30bda	N. Pehl	200	3	Dr	1953	70	D,S	Sd	C, Wad, Ws, oil film.
32acb	G. Vik	90	2	Dr	1913	60	S	Sd	Wad.
33aa	E. Spilde	140	2	Dr	100	S	SdDo....
34dab	B. N. Lein	127	4	Dr	1916	30	S	SdDo....
<u>141-76</u>										
2bbc	K. Pihlaja	100	2	Dr	1915	50	D,S	SdDo....
4cc	A. Holmes	50	2	Dr	1920	30	D,S	SdDo....
6cdd	Federal Land Bank	215	3	Dr	1929	75	D,SDo....
8bb	Bismarck Loan and Invest- ment	150	2	Dr	1926	40	D,S	GvDo....
10dcc	H. Conhain	15	48 x 60	Du	1912	12	D,S	Sd	Win.
12aa	J. Surtela	120	2.5	Dr	1907	40	D,S	Sd	Wad.
12cdd	Federal Land Bank	100	2	Dr	40	D,S	ClayDo....
14aad	E. Coheses	82	2	Dr	1908	40	..	SdDo....
16bba	USGS Test hole 1998	60	5	Dr	7-3-62	T	Sd	1,872.2	BR 43, L.
17cbb	I. Thorsen	40	30 x 30	Du	1911	20	D,S	Clay & Sd	Win.

(1)	(2)	(3)	(4)	(5)	(6)	(7)	(8)	(9)	(10)	(11)
<u>141-76</u>	(Cont.)									
18aa	N. L. Church	125	2	Dr	1921	30	D,S	Clay & Sd	Wad.
18cc	State of N. Dak.	78	5	Dr	1931	25	D,S	Gv	Wad, Wh.
20cbc	Bank of N. Dak.	65	2	Dr	1920	18	D,S	Sd	Wad.
22dca	J. Nokana	80	34 x 34	Du	1908	47	D,S	SdDo....
24bb	Bank of N. Dak.	275	2	Dr	1914	150	D,S	SdDo....
26bc	J. C. Spitzer	75	2.5	Dr	1909	40	D,S	Clay & SdDo....
28ada	USGS Test hole 2000	60	5	Dr	7-2-62	T	..	1,857.4	BR-56, L.
29ccd	USGS Test hole 2001	75	5	Dr	7-2-62	T	..	1,857.6	BR-55, L.
32aad	N. S. Dobbler	200	2	Dr	1921	0	...	Sd	Wad.
34cbb	E. Johnson	30	48 x 48	Du	19	N	Clay & Gv
<u>141-77</u>										
1cdd	USGS Test hole 1999	45	5	Dr	7-3-62	T	Gv	1,892.0	BR-30, L.
2ddd	M. Erickson	160	2.5	Dr	1936	60	D,S	Sd	Wad.
6ccd	Federal Land Bank	50	18	Dr	1912	48	D,S	Clay	Win.
6daa	A. T. Spangberg	70	2	Dr	1907	50	D,S	Wad.
8aab	J. Bender	159	1.5	Dr	1915	125	D,S	SdDo....
12bdd	Bank of N. Dak.	90	2	Dr	1924	16	D,S	SdDo....
14dbd	H. Inget	225	2	Dr	1909	D,S	Ss	Wad, Ws.
18aaa	H. Nelson	400	2	Dr	1914	80	D,S	Sd	Wad.
18bdc	G. Nelson	200	2	Dr	1934	125	D,S	SdDo....
20daa	P. Trygg	280	2	Dr	1918	80	D,S	SdDo....
22dda	J. Neimi	260	2	Dr	1910Do....
24dd	J. C. Pfeiffer	160	2	Dr	10	S	Lig	C, Wad, Ws.
26aaa	Magnolia Petroleum Co.	80	5	Dr	1944	T	L.
28aba	S. Lundquist	200	2	Dr	N
30aa	C. L. Trygg	240	2	Dr	1939	70	D,S	Wad.

(1)	(2)	(3)	(4)	(5)	(6)	(7)	(8)	(9)	(10)	(11)
<u>141-77 (Cont.)</u>										
31aaa	K. Schlepp	120	2	Dr	N
32cdd	E. Lang	180	2	Dr	30	D,S	Lig	Wad, Ws.
33dbb	Patterson Ranch	120	2	Dr	40	N	Sd	Ws.
36caa	M. Agnew	200	2	Dr	1950	120	S	Sd	Wad, Wh.
<u>141-78</u>										
3aa	E. T. Hendershott	98	18	Dr	1937	85	D,S	Sd & Gv	Wad.
4cbb	Stover Estate	39	24	Dr	1930	23	D,S	Sd & Gv	Win.
4dd	E. Ramstad	50	18	Dr	22	N	Sd
5ddd	USGS Test hole 2006	15	5	Dr	7-5-62	T	..	1,929.9	BR-4, L.
8cab	R. Jiras	30	24 x 24	Du	1900	25	D,S	Clay	Wad.
8dda	P. Freeman	45	16	Dr	1904	30	D,S	GvDo....
10ccc	J. Varley	26	2	Dv	1937	18	D,S	SdDo....
11bb	H. Strom	55	2	Dr	1915	45	D,S	SdDo....
12bbc	Bank of N. Dak.	36	18	Dr	1917	31	D,S	Clay	Win.
12cdb	State Land Bank	35	18	Dr	1908	30	N	Gv
14aa	Federal Land Bank	28	4	Dr	1935	25	D,S	Sd	Wad.
14cdc	..do....	245	2	Dr	1933	220	D,S	Clay	Win.
16aa	F. Schroeder	12	48 x 48	Du	1936	5	S	Gv	Wad.
18cc	B. E. Trask	26	54 x 54	Du	1939	20	S	SdDo....
20bdb	F. H. Schroder	356	2	Dr	1912	225	S	SsDo....
20cdc	I. Fricke	100	2	Dr	1915	44	D,SDo....
22bbc	Federal Land Bank	180	4	Dr	1915	150	D,S	SsDo....
26bb	K. Kaiser	148	28	Dr	1935	128	D,S	SdDo....
27bb	Bank of N. Dak.	100	2	Dr	1929	50	D,S	SdDo....
30add	J. Engdahl	145	2	Dr	1915	45	D,S	SdDo....

(1)	(2)	(3)	(4)	(5)	(6)	(7)	(8)	(9)	(10)	(11)
<u>141-78</u> (Cont.)										
30cc	J. Engdahl	155	2	Dr	1914	125	S	Sd	Wad.
31aa	..do....	125	2	Dr	1903	90	N	Sd
35bbb	USGS Test hole 2007	15	5	Dr	7-5-62	T	Gv	1,845.6	BR-12, L.
<u>141-79</u>										
1dcd	W. Ryberg	57	3	Dr	1919	55	D	Sd	Wad.
2aaa	A. Bourgois	40	24	Dr	1922	23	D	SsDo....
3dbd	W. Fricke	210	2	Dr	1904	140	D	SdDo....
6bdc	Carlson Estate	63	24 x 36	Du	1885	61	N	Sd
6ccc	E. Bourgois	40	36 x 36	Du	34	D
7bca	R. H. Lewis	50	24	Dr	45	D	Clay	Win.
7dad	J. Meyer	112	2	Dr	D	Sd	C, Wad.
8bad	..do....	60	20	Dr	1902	50	D	Sd	Wad.
8bcc	N. T. Meyer	59	24	Dr	1914	47	D	SdDo....
9aad	A. M. Rupp	120	3	Dr	1903	115	D	SdDo....
10ccd	H. Kickiel	142	2	Dr	1905	112	D	Sd & GvDo....
10dad	I. J. Falkenstein	134	4	Dr	1919	118	D	SdDo....
12abc	Brown Estate	70	2	Dr	1928	60	D	SdDo....
17cc	H. T. Meyer	175	3	Dv	DDo....
18bdb	G. G. Rupp	40	36 x 42	Du	38	D	SdDo....
18cc1	F. A. Wood	13	30 x 30	Du	1927	10	D	SdDo....
18cc2	I. Fricke	30	24	Dr	28	D	Sd & GvDo....
19bb1	G. G. Rupp	14	24 x 24	Du	1914	12	D,S	Sd & Gv	Win.
19bb2	H. T. Meyer	20	14	Dr	1935	10	D	Sd & Gv	Wad.
19dbc	..do....	35	24	Dr	32	D	SsDo....

(1)	(2)	(3)	(4)	(5)	(6)	(7)	(8)	(9)	(10)	(11)
<u>141-79</u>	(Cont.)									
20dd	Federal Land Bank	80	2	Dr	1925	D	Ss	Wad.
23bba	H. W. Little	100	4	Dr	1910	90	D	ShDo....
24bb	H. Bourgois	114	2	Dr	100	DDo....
24cc	O. Swanson	93	2	Dr	1923	73	D	GvDo....
26bbc	Federal Land Bank	35	48 x 48	Du	1931	29	D	Sd	Win.
29aad	..do....	100	3	Dr	D	Wad.
30abb	J. T. Lenihan	30	48 x 48	Du	1919	25	D	Clay	Win.
30dda	A. R. Lenihan	150	2	Dr	1925	55	D	Sd	Wad.
31aad	D. J. McGillis	390	3	Dr	1933	200	D	SdDo....
33add	Bismarck Loan & Invest- ment	26	8	Dr	1927	23	S	GvDo....
35aa	J. S. Fevold	135	2	Dr	1929	128	D	Sd & GvDo....
<u>141-80</u>										
1cba	R. Spitze	50	24	Dr	1909	40	D,SDo....
3dda	A. E. Anderson	158	4	Dr	1929	D,SDo....
4aa	A. Johnson	60	24	Dr	1914	6	D,SDo....
4cbb	J. M. Jacobson	45	24	Dr	1939	35	D,SDo....
10aad	B. R. Monroe	150	4	Dr	1935	100	D,SDo....
12aca	C. Mount	78	4	Dr	D,SDo....
12baa	E. Strandome	40	48 x 48	Du	1918	36	D,SDo....
14dd	S. E. Strandome	55	24	Dr	1902	50	D,SDo....
18bcd	E. Simons	114	4	Dr	1939	90	SDo....
24baa	E. A. Lewis	32	4	Dr	1919	D,S	SdDo....
27cda	P. Bourgois	198	4	Dr	1932	178	D,SDo....
34bad	A. Christianson	75	24	Dr	1939	50	DDo....
34cab	A. Kooher	60	24	Dr	1923	40Do....
34daa	L. Christianson	40	36 x 48	Du	20	DDo....
35cba	C. DeLong	25	24	Dr	1925	20	DDo....

(1)	(2)	(3)	(4)	(5)	(6)	(7)	(8)	(9)	(10)	(11)
<u>141-80</u> (Cont.)										
35cc	C. DeLong	19	36 x 36	Du	15.75	O,N	Sd
36abd	USGS Test hole 2004	15	5	Dr	6-21-62	T	Gv	1,865.4	BR-9, L.
36bab	W. Larson	126	4	Dr	1911	20	D,S	Wad.
<u>141-81</u>										
2aa	A. Long	26	1.25	Dv	D	SdDo....
12aa	D. Long	80	2	Dr	D,S	SdDo....
36ca	L. Larson	140	2	Dr	D	SdDo....
<u>142-75</u>										
1ddd	B. Wutske	199	3	Dr	1923	60	D,S	Gv	Wad, Wh.
2bbc	L. Trusty	10	48 x 48	Du	6	D,S	Gv	C, Wad, Wal, Wh.
3cc	H. Rachel	90	2	Dr	50	D,S	Sd	Wad.
3ded	E. Jaquous	12	48 x 48	Du	1928	8	D,S	SdDo....
4abc	C. Schopp	30	2	Dr	1926	16	D,S	GvDo....
6bcb	D. Olson	60	16	Dr	1912	40	S	GvDo....
8aa	J. Knittel	6	48 x 48	Du	1934	Flow	D,S	GvDo....
10aca	R. Leach	186	3	Dr	1920	D	Clay & SdDo....
14bbb	I. Eide	132	2	Dr	1916	D,S	Sd & ShDo....
15cda	USGS Test hole 1994	120	5	Dr	6-27-62	T	Sd	1,846.5	BR-112, L.
19ccb	USGS Test hole 1995	210	5	Dr	6-27-62	5.96	T,O	Gv	1,890.1	BR-196, L, C.
22acc	USGS Test hole 2045	195	5	Dr	7-30-62	T	Gv	1,846.0	BR-172, L.
22cac	F. Flews	90	..	Dr	1927	40	D,S	Gv	Wad.
24aaa	H. Ochsner	180	2	Dr	1920	20	D,S	SdDo....
24ccc	J. Trautman	30	36 x 36	Du	3	D,S	SdDo....

(1)	(2)	(3)	(4)	(5)	(6)	(7)	(8)	(9)	(10)	(11)
<u>142-75 (Cont.)</u>										
26bb	J. Alexander	94	..	Dr	1919	27	D,S	Sd	Wad.
26ddb	J. Mehloff	130	..	Dr	1919	13	D,S	Sd	C, Wad.
30bbb	L. R. Beall	100	..	Dr	1914	60	D,S	Sd	Wad.
30cbc	C. Josephson	76	3	Dr	1913	42	D,S	SdDo....
32dbc1	E. Koski	140	2	Dr	1941	45	D,S	Sd	Wad, Wal, Wh.
32dbc2	..do....	223	2	Dr	1959	D	Sd	Wad, Ws.
34bab	W. Kehres	75	2	Dr	1919	S	Sd	Wad, Wh.
34bdd	W. M. Deckert	80	36	Du	1916	63	D,S	GvDo....
35ccc	D. Buller	65	16	Dr	1935	40	D,S	Wad.
<u>142-76</u>										
2ccd	Howard Lanville	57	2	Dr	1963	Flow	D,PS	Sd	C, Wad.
3daa	Unknown	87.75	3	Dr	5.64	S	Gv	Wad, Wh.
3dda	USGS Test hole 1997	75	5	Dr	6-28-62	T	Gv	1,892	BR-57, L.
4bb	Bank of N. Dak.	130	..	Dr	1910	90	D,S	Wad.
6aba	F. Gillig	300	2	Dr	1912	60	D,S	Sd	Wad, Ws.
6dda	T. Fischer	90	2	Dr	1909	40	D,S	SsDo....
7aaa	USGS Test hole 1978	105	5	Dr	4-10-62	T	..	1,994	BR-36, L.
8bdb	Soder Investment	270	3	Dr	1920	35	D,S	Sd	Wad, Ws.
10aac	W. Josephson	58	4	Dr	1924	45	D,S	Clay	Wad.
12bcc	E. Oswald	140	2	Dr	1955	30	D,S	Sd	Wad, Wal, Wh.
14cac	Federal Land Bank	45	36 x 36	Du	1909	40	D,S	Gv	Win.
17aa	Soder Investment	300	3	Dr	200	S	Sd	Wad, Ws.
18aa	S. Hiberstad	170	2	Dr	1928	90	S	Wad.
20bba	Bank of N. Dak.	50	2	Dr	1906	DDo....
22aab	J. Leno	44	24	Dr	1907	10	D,S	Sd	Wad, Wh.

(1)	(2)	(3)	(4)	(5)	(6)	(7)	(8)	(9)	(10)	(11)
<u>142-76 (Cont.)</u>										
22ddd	USGS Test hole 2024	75	5	Dr	6-29-62	T	Sd	1,931.8	BR-57, L.
23bcb	USGS Test hole 1996	30	5	Dr	6-29-62	T	Gv	1,886.0	BR 23, L.
26aab	Federal Land Bank	125	2	Dr	1910	60	D,S	Sd	Wad.
26bcc	S. Sehta	190	2	Dr	1907	180	D,S	ClayDo....
30aaa	Federal Land Bank	150	2	Dr	1919	100	D,S	SdDo....
30baa	Union Investment Co.	200	2	Dr	1922	50	D,S	SdDo....
<u>142-77</u>										
2add	M. Thorston	100	2.5	Dr	47	D,S	SdDo....
4bbb	V. Little	60	24	Dr	D	ClayDo....
4ddd	C. Little	405	4	Dr	1959	30	D,S	Sd	C, Wad, Ws.
5add	..do....	120	4	Dr	1960	30	S	Sd	Wad, Ws.
6bcc	R. Nelson	65	2	Dr	1955	32	D,S	Sd	Wad, Wh.
10abb	S. W. Newitz	35	24	Dr	1915	33	D,S	Sd	Win.
15aa	W. Hoerr	10	30 x 30	Du	1936	7	S	Clay	Wad.
16add	Hopkins Ranch	200	2	Dr	1960	D,S	Sd	Wad, Ws.
18cbc	A. Ryberg	96	2	Dr	1909	90	S	Lig	Wad.
20bba	Bank of N. Dak.	100	4	Dr	1923	80	D,S	SdDo....
20ccc	Federal Land Bank	80	24	Dr	1909	60	D,SDo....
21cdc	A. Anderson	12	30 x 30	Du	1929	9	D,S	SdDo....
22dd	S. E. Olson	180	2	Dr	1909	125	D,S	SsDo....
24bac	L. Hopkins	14	60 x 60	Du	1928	10	D,S	SdDo....
26bcc	Dr. Brandt	38	24	Dr	1934	20	D,S	SdDo....
30aaa	A. Olson	68	3	Dr	1915	40	D,SDo....
30bac	K. Hettick	60	6	Dr	1909	20	D,S	ClayDo....
32ccb	O. Magnuson	37	18	Dr	1913	30	D,S	SdDo....
34bb	S. A. Nelson	45	6	Dr	1932	35	D,S	ClayDo....
34ccd	..do....	34	48 x 48	Du	1915	34	N	Clay	Win.

(1)	(2)	(3)	(4)	(5)	(6)	(7)	(8)	(9)	(10)	(11)
<u>142-77</u>	(Cont.)									
34dd	E. Noset	67	18	Dr	1913	52	D,S	Clay	Wad.
<u>142-78</u>										
2dcd	T. E. Morris	75	6	Dr	1909	50	D	SdDo....
3ddc	Federal Land Bank	36	24	Dr	34	D	GvDo....
4adb	F. B. Shala	70	3	Dv	50	D	LigDo....
4bcc	H. B. Gill	40	4	Dr	1922	30	D	SdDo....
5aaa	N. Tosseth	52	24	Dr	48	D	SdDo....
5bb	A. Strom	67	3	Dr	1927	39	D	LigDo....
6adb	V. Strom	64	20	Dr	1914	24	D	LigDo....
6ccc	A. B. Johnson	72	4	Dr	1917	20	D	GvDo....
8bbc	A. Hedstrom	100	6	Dr	1920	70	D	ClayDo....
8cac	A. Tosseth	100	4	Dv	1904	70	D	SdDo....
8cbb	E. Sundquist	120	4	Dv	1920	70	DDo....
9aaa	W. A. Drawver	72	4	Dr	1919	52	D	SdDo....
9bab	W. H. Gill	39	24	Dr	1916	31	D	SdDo....
10bbc	J. Spangberg	100	4	Dr	1927	40	D	SdDo....
11cbb	V. Engelbritson	72	6	Dr	1927	15	D	ClayDo....
12bab	S. R. Little	48	4	Dr	1909	D,S	GvDo....
12cc	J. Kierland	70	4	Dr	1913	60	...	ClayDo....
12dd	A. Ryberg	100	4	Dr	50	DDo....
13bbb	C. W. Magnuson	70	18	Dr	1909	52	N	SdDo....
14aa	H. J. Magnuson	62	24	Dr	1904	52	D	SdDo....
14bcc	M. V. Magnuson	70	24	Dr	1908	52	D,S	SdDo....
14cdd	A. Anderson	52	24	Dr	1917	49	D	ClayDo....
15daa	N. Alm	16	36 x 36	Du	1915	14	DDo....
18bca	Coleman Estate	120	4	Dr	1920	DDo....
20bb	F. Perkins	145	2	Dr	100	DDo....

(1)	(2)	(3)	(4)	(5)	(6)	(7)	(8)	(9)	(10)	(11)
<u>142-78</u>	(Cont.)									
21cdb	H. Brosts	110	5	Dv	1922	90	D	Sd	Wad.
22bbd	A. Rupp	75	24	Dr	35	DDo....
23ceb	W. J. Schimanski	68	24	Dr	1911	55	DDo....
24bb	Bank of N. Dak.	77	3	Dr	60	D	SdDo....
24ccc	O. W. Backman	142	6	Dv	1922	135	DDo....
26cbc	Bank of N. Dak.	60	4	Dv	50	DDo....
26dd	C. W. Scott	127	4	Dr	67	D	SdDo....
28aaa	E. Olson	60	24	Dr	50	SDo....
28bdb	A. Helgeson	80	3	Dr	1927	60	D	ClayDo....
29bac	L. V. Siand	50	6	Dr	1919	40	D	Ss	Win.
30bbb	Federal Land Bank	110	3	Dr	1935	D	Gv	Wad.
32ccd	R. Cohan	75	4	Dr	SdDo....
33daa	L. Mennenga	34	6	Dr	1931	13	D	GvDo....
35ddc	O. Coleman	14	48 x 48	Du	1925	8	D	SdDo....
<u>142-79</u>										
2ddc	H. H. Speten	67	24	Dr	1937	55	D,SDo....
3cc	V. Franklund	50	6	Dr	35	S	Sd	Win.
4cdc	T. J. Asplund	190	2	Dr	D,S	Wad.
4dd	B. Anderson	40	36	Du	10	S	Sd	Win.
6cbc	R. D. Flavin	62	24	Dr	30	S	Lig	Wad.
8bcb	Eckland Bros.	45	24	Dr	1916	38	D,SDo....
8dbb	E. E. Backman	68	24	Dr	1908	55	D,S	ShDo....
9aa	McCahey Bros.	60	24	Dr	1925	50	S	LigDo....
10abb	H. C. Asplund	35	24	Dr	33	D,S	LigDo....
10bbb	A. Fesberg	27	24	Dr	4	S	Win.

(1)	(2)	(3)	(4)	(5)	(6)	(7)	(8)	(9)	(10)	(11)
142-79 (Cont.)										
11baa	R. Taplin	85	2	Dr	75	D,S	Sd	Wad.
11cc	H. Taplin	249	2	Dr	1934	180	D,SDo....
12aba	W. Falkenstein	60	4	Dr	55	D,S	Win.
12bba	H. Taplin	105	4	Dr	1919	73	D,S	Sd	Wad.
12ccc	L. Johnson	84	24	Dr	1937	80	D,S	LigDo....
13bbc	E. Kling	100	2	Dr	80	D,SDo....
14cc	J. Vollan	120	2	Dr	1925	100	D,S	SdDo....
14dd	A. F. Anderson	150	4	Dr	1911	140	D,S	SdDo....
15bba	A. Hagstrom	260	4	Dr	225	D,S	SdDo....
16ccd	A. Hedberg	200	4	Dr	1911	190	N	Sd	Win.
18ddc	L. Gordon	50	24	Dr	1934	40	D,SDo....
19bb	S. Schules	160	4	Dr	1912	D,S	Sd	Wad.
20bbd	G. E. Gordon	140	2	Dr	1907	135	D,S	GvDo....
21cc	P. Monroe	283	2	Dr	1927	200	D,S	SdDo....
22aa	A. Engstrom	156	2	Dr	135	D,S	LigDo....
22cab	W. Spangerg	183	2	Dr	1925	175	D,S	SdDo....
24dcc	J. M. Thompson	90	3	Dr	1900	80	D,S	SdDo....
26acb	V. Franklin	58	5	Dr	1960	21	D,S	Gv	C, Wad, Wh.
26cdd	H. McCullough	75	3	Dr	65	D,S	Wad.
26ddd	USGS Test hole 2005	45	5	Dr	7-3-62	T	Gv	2,027.6	BR-20, L.
27ccd	J. Sorch, Jr.	151	3	Dr	1919	126	D,S	Sd	Wad.
28bda	E. Hilker	52	24	Dr	1912	25	D,S	SdDo....
29cc	L. Fisher	120	2	Dr	1920	100	D,S	SdDo....
29dad	J. Sorch	157	2	Dr	1933	140	D,S	SdDo....
30aa	C. Krotz	74	18	Dr	70	D,S	Win.

(1)	(2)	(3)	(4)	(5)	(6)	(7)	(8)	(9)	(10)	(11)
142-79 (Cont.)										
30cc ²	C. Spitzer	94	24	Dr	1932	80	D,S	Gv	Wad.
31bbb	A. W. Franklund	56	24	Dr	53	D,S	SsDo....
32bcb	L. Spitzer	56	24	Dr	50	D,S	GvDo....
32ddd	J. Sorch	190	2	Dr	1909	170	D,SDo....
33bda	H. Diede	70	24	Dr	1934	50	D,S	SdDo....
36abb	H. Brown	30	24	Dr	20	D,S	GvDo....
142-80										
1bdb	N. Krush	85	24	Dr	1936	70	S	GvDo....
2abb	City of Wilton #1	220	3	Dr	60	T	Sd	L.
2bb	A. Kilian	180	2	Dr	1928	150	D,S	Sd	Wad.
3aaa	USGS Test hole 1985	225	5	Dr	6-20-62	T	Sd	2,170.9	BR-7, L.
4baa	M. Triska	40	24 x 24	Du	32	D,S	Sd & Gv	SC-1,250, Wad, Wh.
5cdd	Wilton Mutual Store	80	24	Dr	1932	78	S	Ss	Win.
6aaa	P. K. Katman	71	24	Dr	44	D,S	Gv	Wad.
6bb	D. Iverson	60	24	Dr	1900	54	N	LigDo....
8bbb	J. Brown	228	2	Dr	1912	190	D,S	Sd	SC-2,477, Wad, Ws.
8dd	A. Nelson	12	48 x 48	Du	1933	8	D,S	Clay	Wad.
9bdb	R. Backman	208	4	Dr	1946	150	D,S	Sd	SC-1,700, Wad, Ws.
10bb	D. Bost	100	24	Dr	1915	95	D,S	Lig	Wad.
10cdc	G. Doerr	165	4	Dr	125	D,S	SdDo....
12aa	G. Pfeiffer	62	24	Dr	1889	49	N	Sd	Win.
12bbc	M. Garowski	150	2	Dr	1931	80	D,S	Wad.
12dcc	E. A. Gray	48	24	Dr	1935	46	N	SdDo....
13bba	S. M. Anderson	50	48 x 48	Du	1908	35	D,S	ClayDo....
14ccc	A. Gorden	35	4	Dr	20	D,S	Wad, Wh, T.-47°F.
17aa	A. Stenquist	160	4	Dr	1916	90	D,S	Wad.
19cdc	H. Johnson	34	48 x 48	Du	1922	30	D,S	GvDo....

(1)	(2)	(3)	(4)	(5)	(6)	(7)	(8)	(9)	(10)	(11)
<u>142-80</u> (Cont.)										
20bbc	W. A. Johnson	50	24	Dr	1912	48	N	Clay
21adb1	F. Murrey	60	4	Dr	1931	38	D,S	Sd	SC-1,380, Wad, Wh.
21adb2	..do....	180	1.5	Dr	1956	D	Sd	SC-1,600, Wad, Ws.
21bb	L. Maynard	45	24	Dr	1926	35	D,S	Sd	Wad.
22baa	D. Murrey	240	3	Dr	70	S	Lig	Wad, T.-48°F.
23aa	J. Chubey	54	4	Dr	1936	50	S	Lig	Wad.
24aa	C. Peterson	42	24 x 24	Du	1885	36	D,S	ClayDo....
24dbc	G. Montgomery	42	24	Dr	1936	34	D,S	LigDo....
26ccd	J. Partyka	200	2	Dr	D,S	GvDo....
29cdb	G. Hagen	200	2	Dr	1917	100	D,S	GvDo....
31aba	D. Albright	28	24	Dr	1934	23	D,S	Gv	Win.
34ddc	A. E. Holden	200	2	Dr	1915	170	D,S	Ss	Wad.
35cbb	S. Moisa	200	2	Dr	1937	100	D,S	SsDo....
36cbc	P. Strandemo	101	2	Dr	1926	70	D,S	Sd & GvDo....
<u>142-81</u>										
1dd	H. Thompson	14	2	Dv	1934	10	D,S	SdDo....
2aab1	J. Franklund	101	3	Dr	1951	50	S	Sd	SC-1,455, Wad, Wh.
2aab2	..do....	85	2	Dr	1950	45	D	Sd	Wad, Wh.
2baa	F. Brown	240	2	Dr	1960	20	D	SC-2,036, Wad, Ws.
4adc	USGS Test hole 1984	435	5	Dr	6-21-62	Flow	T	Ss	1,666.3	BR-7, C, L.
12bab	N. Erickson Estate	77.60	30	Du	1925	63.98	N
13aaa	A. Peterson	150	2	Dr	1948	D,S	Sd	Wad, Wh, T.-48°F.
14abd	C. Peterson	54	24	Dr	1941	D,S	Sd	SC-1,200, Wad, Wh.
14bca	F. Nelson	55	24	Dr	1912	45	N	Clay
15bc	B. Biersterfield	45.1	24	Dr	27.30	S	Sd	Wad.

(1)	(2)	(3)	(4)	(5)	(6)	(7)	(8)	(9)	(10)	(11)
<u>142-81</u>	(Cont.)									
15cd	R. E. Hogen	37	1.25	Dv	D,S	Sd	Wad.
22ab	..do....	12.2	100	Du	1.83	N	SdDo....
22ac	..do....	37.8	18	Dr	29.62	N	SdDo....
22ddb	L. Davenport	47	4	Dr	1961	20	S	Sd & Gv	C, Wad, Wh.
23ccb	..do....	96	4	Dr	1948	75	D,S	Lfg	Wad, Ws.
24cda	Federal Land Bank	36	24	Dr	1936	32	D,S	Win.
26db	N. Simonson	18.6	18	Dr	5.23	D	Sd	Wad.
27bab	D. C. Swanks	28	2	Dv	1931	20	D,S	SdDo....
35aab	T. Morgan	100	2	Dr	1917	44.99	D,S	GvDo....
36cac	G. Larson	115	2	Dr	1920	40	D,S	SdDo....
36cdd	W. Johnson	132	2	Dr	1929	80	D,S	SdDo....
36ddd	D. Riebe	60	24	Dr	1939	10	D,S	Ss	Win.
<u>143-75</u>										
2cddl	E. Wagner	65	18	Dr	1911	40	S	Gv	Wad, Wal, Wh.
2cdd2	..do....	85	2	Dr	1946	25	D,S	GvDo....
3acc	L. Dockter	67	3	Dr	1961	16	S	Sd	Wad, Wh.
4add	..do....	130	3	Dr	45	D,S	Sd	Wad, Wal, Wh.
6cbc	J. Harris	40	24	Dr	1908	20	S	Clay & Gv	Wad.
8abd	Federal Land Bank	...	3	Dr	1910	30	S	Sd	Win.
9dcc	Soder Investment Co.	187	2.5	Dr	1933	D,S	Wad.
13ccd	J. Wutzke	140	2	Dr	1916	25	D,S	SsDo....
14aa	E. Sandberg	142	3.5	Dr	1918	20	D,S	ClayDo....
14bb	J. Wolff	180	2	Dr	1958	40	S	Sd	Wad, Ws.
16acc	USBR drill hole 41	40	3	Dr	1960	6.9	T	Sd	1,897.6	L.
16bdd	USBR drill hole 40	45	3	Dr	1960	8.1	T	Sd	1,902.9	..Do....
17aac	USBR drill hole 39	30	3	Dr	1960	30	T	Sd	1,900.5	..Do....
18aaa	H. Trautman	130	3	Dr	37	D,S	Sd	C, SC-1,768, Wad.
19acc	..do....	137	4	Dr	67	S	Sd	Wad.

(1)	(2)	(3)	(4)	(5)	(6)	(7)	(8)	(9)	(10)	(11)
<u>143-75 (Cont.)</u>										
19daa	USGS Test hole 2056	105	5	Dr	7-31-62	T	..	1,892	BR-81, L.
20cc	R. Bailey	105	4	Dr	1926	50	S	Sd & Gv	Wad.
20dab	C. Rath	153	2.5	Dr	1916	30	S	SdDo....
22bab1	J. Wolff	50	3	Dr	1906	40	S	Sd	Win.
22bab2	..do....	140	2	Dr	1958	25	D,S	Sd	Wad, Ws.
23cdd	C. Wagner	185	2	Dr	1962	75	S	SdDo....
24dad	USBR drill hole 42	60	3	Dr	1960	4.9	T	..	1,862.4	L.
26abc	C. Wagner	195	2.5	Dr	1910	70	S	Sd	Wad.
26bcb	J. Gilner	90	24	Dr	1909	80	S	Win.
29acc	A. J. Batter	120	4	Dr	1960	30	S	Sd	Wad.
30cdd	F. Miller	269	2	Dr	1933	153	N	Sd
32bcc	A. J. Batter	180	3	Dr	40	S	Sd	Wad.
32ccc	A. Kraft, Jr.	23.41	30 x 30	Du	11.73	S	Sd	Wad, Wh.
35ccb	L. Trusty	60	2	Dr	1963	12	S	Sd	C, Wad.
<u>143-76</u>										
3ddc	Patterson Land Co.	240	2	Dr	1919	40	D,S	Wad.
4baa	V. Miller	196	2	Dr	120	S	SdDo....
6bdb	J. Skei	33	36 x 36	Du	30	D,SDo....
6ddd	H. G. Bailey	60	4	Dr	1947	12	D,S	Sd	Wad, Wh.
7baa	USGS Test hole 1991	75	5	Dr	6-26-62	T	..	1,932	BR-30, L.
7ddd	E. Sorlie	60	4	Dr	16	D,S	Gv	Wad, Wh.
8ccc	G. Harmon	39	48 x 48	Du	1938	28	D,S	Sd	Win.
10ccd	D. Bossert	46	30	Dr	35	D,S	Clay	Wh, Win.
10ddd	A. Dagner	40	24	Dr	1934	22	D,S	Sd	Wad.
12da	USBR drill hole 38	40	3	Dr	1960	8.3	T	Silt	1,973.3	L.

(1)	(2)	(3)	(4)	(5)	(6)	(7)	(8)	(9)	(10)	(11)
<u>143-76</u> (Cont.)										
13ccd	G. Jackson	180	2	Dr	1936	40	D,S	Sd	C, Wad, Ws.
14bcb	C. Berg	62	24	Dr	54	S	Gv	Wad.
15baa	D. Bossert	230	4	Dr	1962	80	S	Gv	Wad, Wh.
20adc	O. Jacobson	160	3	Dr	84	D,S	Sd	Wad, Ws.
22aab	J. Weber	60	24	Dr	25	S	Wad.
22dad	M. Hochbatter	50	3	Dr	D,S	SdDo....
25caa	G. Jackson	135	2	Dr	1958	D,S	Ss	Wad, Ws.
28ddc	B. Michel	30	48 x 48	Du	1902	20	D,S	Wad.
30dcc1	H. Williams	330	2	Dr	1960	230	D,S	Sd	Wad, Ws.
30dcc2	..do....	285	3	Dr	1955	180	S	ClayDo....
32bb	..do....	280	2	Dr	1958	98	S	ClayDo....
33a	C. Josephson	190	2	Dr	S	Sd	C, Wad.
<u>143-77</u>										
2aab	J. Novy	180	6	Dr	1908	150	D,S	Sd	Wad.
6abb	A. H. Lundberg	45	48 x 48	Du	1934	40	D,S	Win.
6bcc	G. Mowder	50	6	Dr	1924	30	D,S	Sd	Wad.
6ccc	Federal Land Bank	65	30	Dr	1900	50	D,S	ClayDo....
6dcc	Bank of N. Dak.	...	4	Dr	1905	70	D,S	SdDo....
8cc	R. H. Lundberg	120	3	Dr	1957	25	D,S	SdDo....
10bb	M. Hienkenmer	90	4	Dr	1905	80	D,S	Clay	Win.
11dd	R. H. Lundberg	128	3	Dr	1955	55	S	Sd	Wad, Wh.
12cdc	State Land Bank	125	2	Dr	45	D,S	Sd	Wad.
14adc	Federal Land Bank	70	2	Dv	1914	60	D,SDo....

(1)	(2)	(3)	(4)	(5)	(6)	(7)	(8)	(9)	(10)	(11)
<u>143-77</u> (Cont.)										
14bb	M. Lendsay	65	6	Dr	1910	55	D,S	Ss	Wad.
14ccd	J. McCoy	65	6	Dr	1910	60	D,S	Sd	Win.
16ccb	C. Morris	60	4	Dr	1957	30	D,S	Gv	Wad, Wh.
17dcc	R. H. Lundberg	61	3	Dr	1949	23	D	Sd	C, Wad, Wh.
18aca1	A. Strand	25	36 x 36	Du	1902	20	N	Win.
18aca2	..do....	45	6	Dr	1925	30	D,S	Wad.
21dad	School land	75	4	Dr	1926	70	D,S	Sd	Win.
22ccb	O. Olson	175	2	Dr	1915	25	D,S	Sd	Wad.
24baa	M. Walters	160	2	Dr	1918	62	D,S	SdDo....
25dd	H. Williams	160	2	Dr	1961	50	S	Clay	Wad, Wh.
28dda	C. Little	16,00	2	Dr	6.76	N	Sd
30aca	N. Schroder	80	2	Dr	1928	40	D,S	Gv	Wad.
30cdc	C. McCullough	464	2	Dr	1960	200	D,S	Sd	C, Wad, Ws.
31cbb	H. D. Watkins	110	6	Dr	1928	50	D,S	Wad.
31dd	F. P. Rusch	75	6	Dr	60	D,SDo....
34bb	H. C. Patton	90	4	Dr	1924	20	D,S	Sd	Win.
<u>143-78</u>										
2aabl	Folmer	110	3	Dr	1955	S	Sd	Wad, Wh.
2aab2	..do....	235	2	Dr	1953	40	D	Sd	Wad, Ws.
2ddd	W. N. Uhde	92	4	Dr	1904	64	D,S	Wad,
3bbc	J. E. Carlson	100	6	Dr	1920	50	D,S	Sd	Win.
4bcc	Bank of N. Dak.	90	4	Dr	20	D,S	Sd	Wad.
4cc	J. Hausauer	43	24	Dr	1929	41	D,S	SdDo....
6aba	N. L. Church	85	6	Dr	75	DDo....
7cbb	USGS Auger hole 26	52	3	Dr	10-24-62	T	BR-44, L.
9bba	C. Hausauer	279	2	Dr	1945	80	D,S	Sd	Wad, Ws.
10ccc	J. E. Zelmer	93	4	Dr	36	D,SDo....

(1)	(2)	(3)	(4)	(5)	(6)	(7)	(8)	(9)	(10)	(11)
<u>143-78</u> (Cont.)										
10dcc	P. Michelson	76	4	Dr	1917	14	D,S	Sd	Wad, Ws.
11daa	E. A. Jose	60	3	Dr	D,S	Gv	Wad, Wh.
12aad	Agriculture Credit Corp.	60	6	Dr	1919	50	Wad.
12ddd	L. Goll	89	4	Dr	39.05	S	Sd	C, Wad.
13cc	F. Folmer	108	5	Dr	1920	30	N	Sd	
13dda	N. W. Davenport	113	4	Dr	73	D,S	Sd	Win.
14aba	W. M. Udhe	90	6	Dr	1914	80	D,S	Gv	Wad, Wh.
18abc	O. Hagstrom	111	4	Dr	60	D,S	SdDo....
18bbb	USGS Auger hole 20	25	3	Dr	10-62	T	L.
18ddc	G. L. Johnson	300	4	Dr	1934	117	D,S	Ss	Wad, Ws.
20aa	N. H. Broehl	16	24 x 44	Du	1934	8	N	Sd
20cda	P. Johnson	50	6	Dr	1938	38	D,S	Sd	Wad.
20dbd	D. E. Ghylin	40	24	Dr	1916	36	D,S	SdDo....
21dad	J. Wise	80	4	Dr	1911	D,S	Sd	Wad, Wh.
23aa	G. Michelson	84	4	Dr	1918	30	N	Sd
23ccc	W. Michelson	85	4	Dr	1918	22	D,S	Ss	Wad.
24bbb	A. McCullough	93	4	Dr	1959	40	D,S	Gv	Wad, Wh.
24dcc	F. Reimann	65	4	Dr	1946	D,S	SdDo....
25dd	McHugh	140	4	Dr	80	N
28ccc	L. Lundberg	85	4	Dr	1916	50	D,S	LigDo....
28dad	A. Manning	65	4	Dr	1950	26	D,S	SdDo....
30bbc	D. Bauer	30	48 x 48	Du	1960	10	D,S	SdDo....
31dcc	Federal	50	18	Dr	1930	25	S	Clay	Wad.
32aba	L. Lundberg	85	4	Dr	48	S	Sd	Wad, Wh.
32ccc	B. T. Benson	52	24	Dr	1926	30	D,S	Ss	Wad.

(1)	(2)	(3)	(4)	(5)	(6)	(7)	(8)	(9)	(10)	(11)
<u>143-78</u> (Cont.)										
34ddc	J. Keefer	58	24	Dr	50	D,S	Sd	Wad.
35bdd	B. Worden	65	6	Dr	1925	35	D,S
35cc1	A. T. Tourtloote	36	4	Dr	1929	30	D	LigDo....
35cc2	C. N. Lien	42	5	Dr	1939	36	D	SdDo....
35ccc	USGS Test hole 1990	135	5	Dr	6-26-62	T	Sd	2,042.9	L, BR-32.
<u>143-79</u>										
2cbb	M. H. Kozek	44.12	42 x 42	Du	1903	41.62	N
4cc	N. Spohnagatch	65	24	Du	60	N	Clay	Win.
5aa	P. Osheny	80	24	Dr	1933	72	N	ClayDo....
6cbc	E. W. Aune	82	4	Dr	1941	18	D,S	Sd	Wad, Ws.
6dda	Agriculture Corp.	35	24	Dr	1926	34	D,S	Sd	Win.
8cda	C. W. Noon	43	24	Dr	1927	23	D,S	Wad.
8dbc	D. Noon, Jr.	431	3	Dr	1959	10	D,S	Ss	Wad, Ws.
10baa	USGS Auger hole 19	89.5	3	Dr	10-19-63	60	T	Sd	BR-79, L.
10bbc	E. Johnson	40	4	Dr	1958	25	D,S	Sd	Wad, Wh.
11aad	USGS Auger hole 25	52	3	Dr	10-23-62	T	Sd	BR-46, L.
13bcbl	O. Hagstrom	300	2	Dr	1951	80	D,S	Sd	Wad, Ws.
12bcbl	Erickson Bros.	60	24	Dr	1919	45	D,S	C, Wad.
14cbb	F. Hentz	44	54 x 54	Du	1936	28	N	Clay	Wad.
14dad	USGS Auger hole 27	97	3	Dr	10-24-62	T	BR-95, L.
15cc	S. Beranick	60	2	Dr	1936	52	D,S	Sd	Win.
17ada	R. Johnson	50	18	Dr	1903	45	D,S	Sd	Wad, Wh.
18bcbl	J. Noon	110	4	Dr	1936	50	D,S	Gv	Wad.
18bcc	..do....	120	4	Dr	1927	80	D,S	GvDo....
20cdd	J. Olson	33.31	24	Dr	1909	20.48	N
21cbb	H. Thor	46	24	Dr	1932	38	D,S	Clay	Wad.

(1)	(2)	(3)	(4)	(5)	(6)	(7)	(8)	(9)	(10)	(11)
<u>143-79</u>	(Cont.)									
21ddd	J. Law	70	2	Dr	1927	60	N	Win.
23bcc	W. Noon	50	4	Dr	1961	5	D,S	Sd	Wad, Wh.
24bdb	N. Asplund	35	2	Dr	1919	30	D,S	Clay	Win.
24dbb	J. Johnson	41	24	Dr	1936	26	D,S	Sd	Wad.
26ccb	L. M. Nordquist	32	24	Dr	1937	20	D,S	LigDo....
26daa	A. Asplund	30	48 x 48	Du	1904	15	D,S	SdDo....
27ccc	H. Danielson	49	6	Dr	1932	36	D,S	SdDo....
27dcc	C. Olson	55	18	Dr	1934	50	D,S	Clay	Win.
28ada	R. Johnson	30	8	Dr	1936	19	D,S	Sd	Wad.
28cc	F. Achernecker	50	24	Dr	1916	35	N	Sd
28dd	A. Thor	61	24	Dr	1935	53	N	Clay
29aa	M. Magnuson	50	2	Dr	1933	35	N	Clay
29ddc	O. M. Thor	47	72 x 72	Du	1909	45	D,S	Wad.
30aa	J. Dahlgren	50	24	Dr	1935	36	D	LigDo....
30cc	L. Backman	276	4	Dr	1928	75	D,S	SdDo....
30dda	G. Webber	44	3	Dr	1936	28	D,S	ClayDo....
32baa	H. Renner	62	36	Dr	49	D,S	Sd	C, Wad, Wh.
33aa	A. Thor	45	2	Dr	1923	38	D	Clay	Win.
34bcc	..do....	42	36	Du	1895	32	D,S
34ccc	V. Enstrom	32	24	Du	1932	30	D,S	Gv	Wad.
36bbb	J. L. Asplund	32	38 x 38	Du	1914	20	D,S	SdDo....
36ccc	W. Asplund	50	2	Dr	1910	20	D,S	SdDo....
36ddd	A. Backman	50	2	Dr	1907	33	D,S	LigDo....
<u>143-80</u>										
35daa1	City of Wilton #1	96	10	Dr	81	PS	Sd	C, Win, produces 18 gpm.
35daa2	City of Wilton #2	164	4	Dr	62	T	Sd	L.
36cbb1	City of Wilton #4	101	10	Dr	95	PS	Sd	Win, produces 14 gpm.
36cbb2	City of Wilton #3	104	4	Dr	64	T	Sd	L.

(1)	(2)	(3)	(4)	(5)	(6)	(7)	(8)	(9)	(10)	(11)
<u>144-75</u>										
4ccc	A. Dockter	40	36	Du	1922	25.04	D,S	Sd & Gv	SC-2,470, Wad, Wh.
6ccc1	O. Biech	220	2	Dr	1952	D,S	Sd	SC-1,890, Wad, Ws.
6ccc2	..do....	40	24	Dr	20	S	Sd	Wad.
7cbc	T. Hertz	350	3	Dr	1956	D,S	Sd	SC-2,300, Wad.
8cbb	State Bank of N. Dak.	160	3	Dr	30	D,S	Wad.
8dbb	Federal Land Bank	64	24	Dr	62	D	Win.
10ada	L. Schaeffer	140	2	Dr	D,S	Wad, Ws.
10baa	J. Sutter	40	24	Dr	20	D,S	Wad.
15aaa	USGS Test hole 1993	112	5	Dr	6-27-62	T	..	2,016	BR-110, L.
20aa	A. Wilkinson	120	2	Dr	1914	D,S	Ss	Wad.
20dcd	D. Glanville	130	3	Dr	85	D,S	Sd	SC-120, Wad.
22ddd	State Bank of N. Dak.	132	2	Dr	1926	D,S	Wad.
23ccd	H. Albers	156	2.5	Dr	1914	DDDo....
24bbc	R. Papke	270	4	Dr	1957	100	D,S	Sd	SC-2,360, Wad.
28dd	S. McIntyre	160	4	Dr	1930	60	D,S	Wad.
32cbb	A. Vollmer	300	2	Dr	1952	60	D,S	Sd	C, SC-2,680, Wad.
34abc	E. Pond	20	36	Du	1933	18	D,S	Clay	Wad.
35cbc	J. Miller	42	3	Dr	1962	10	D,S	Gv	C, Wad.
35da	..do....	185	2	Dr	1961	40	S	Sd	Wad, Wh.
<u>144-76</u>										
6aad	J. Witt	10	48	Du	1936	6	D,S	Gv	Wad.
7dad	USGS Test hole 2052	150	5	Dr	8-1-62	T	Gv	1,929	BR 135, L.
8dd	H. Steve	27	24	Dr	1938	23	D,S	Sd	Win.
9caa	H. Crimmins	128	2	Dr	1956	30	S	Idg	Ws.
9ccc	J. Fitzgerald	10	36	Du	1908	8	D,S	Sd	Win.

(1)	(2)	(3)	(4)	(5)	(6)	(7)	(8)	(9)	(10)	(11)
<u>144-76</u> (Cont.)										
10cdd	E. Glannville	24	48	Du	1918	22	D,S	Gv	Wad.
12bbb	USGS Test hole 2044	180	5	Dr	7-31-62	T	Gv	1,950	BR-165, L.
12ccc	R. Rauscher	160	2	Dr	1954	50	D,S	Gv	Wad, Wh.
14dcc	E. Heinrich	120	3	Dr	1961	15	D,S	Sd	SC-1,380, Wad.
18daa	J. Bernhardt	31	48	Du	1934	23	D,S	Gv	C, Wad, Wh.
19dbb	H. Crimmins	131	4	Dr	1962	15	S	Gv	Wad, Wh.
19dd	..do....	3	30	Du	1936	Flow	S	Gv	Spring.
20bbc	J. Bernhardt	45	2	Dr	N	Gv	Wh.
21dd	C. Kindred	196	6	Dr	1926	146	D,S	Gv	Wad.
22ccd	E. Sellinger	208	2.5	Dr	1936	48	S	Sd	Wad, Ws.
23bcc	E. Heinrich	120	3	Dr	1961	15	S	Sd	Wad.
24daa	J. Tees	200	3	Dr	1918	60	D,S	GvDo....
26aa	F. Smith	180	2	Dr	1909	140	SDo....
27bba	E. Sellinger	209	2	Dr	1959	40	D,S	Sd	Wad, Ws.
29aaa	USGS Test hole 1992	75	5	Dr	6-27-62	T	Sd	1,968	BR-67, L.
30aaa	V. Bailey	35	6	Dr	1932	7	D,S	Sd	Wad.
30bbc	C. Johnson	37	36	Du	1907	31	D,S	SdDo....
30dce1	H. Crimmins	133	4	Dr	1956	40	D,S	GvDo....
30dce2	..do....	120	2	Dr	1950	60	S	GvDo....
31bcd	USBR drill hole 36	25	3	Dr	1960	21.8	T	Sd	1,936.9	L.
31dbb	USBR drill hole 37	35	3	Dr	1960	7.0	T,0	Sd	1,932.3	..Do....
32add	H. Bailey	70	4	Dr	1908	66	D,S	Clay	Wad.
35ccb	J. Scallon	200	3	Dr	1918	150	D,S	SsDo....
<u>144-77</u>										
1caa	H. Crimmins	133	4	Dr	1961	40	S	Sd	Wad, Wh.
2ddd	A. Bender	22	36	Du	1934	20	S	Gv	Win.
3dbd	Unknown	22.48	48	Du	1.26	S	Gv	Wad.
4bcc	G. Migrin	14	36	Du	1910	6	D,S	Sd & GvDo....
4cdc	J. Streh	16	36	Du	1926	13	D,S	GvDo....

(1)	(2)	(3)	(4)	(5)	(6)	(7)	(8)	(9)	(10)	(11)
144-77 (Cont.)										
7aaa	C. Kvasnicka	35	36	Du	1927	27	S	Sd & Gv	Wad.
8aaa	T. Roubal	300	2	Dr	1948	48	D,S	Sd	Wad, Ws.
8aab	USGS Auger hole 23	112	3	Dr	10-23-62	87	T	Sd	BR-32, L.
8bbc	R. Rasmussen	385	2	Dr	1940	40	D,S	Ss	Wad, Ws.
9caa	T. Roubal	300	2	Dr	1948	35	S	SdDo....
12cbb	C. Knudson	197	4	Dr	1930	60	D,S	Sd & Gv	Wad.
15acc	R. Celley	215	4	Dr	1962	10	S	Lig & SdDo....
15ddc	..do....	217	2.5	Dr	1957	70	S	Sd	Wad, Ws.
17caa	A. J. Braun	135	2	Dr	1950	30	S	SdDo....
17dd	Halvorson Bros.	65	4	Dr	1960	40	S	Sd	Wad, Wh.
18daa	USGS Test hole 1988	60	5	Dr	6-26-62	T	Sd	1,408.1	BR-42, L.
18dd	B. Danielson	65	24	Dr	1910	38	D,S	Gv	Win.
19aab	Halvorson Bros.	40	4	Dr	1952	9	D,S	Gv	Wad, Wh.
20bca	E. Sohuh	60	30	Dr	1923	35	N	Gv
21acc	R. Celley	207	4.5	Dr	1961	5	S	Sd	Wad.
23aab	A. Novy	200	2	Dr	1919	150	D,S	SdDo....
23bad	J. Novy	70	4	Dr	1924	50	D,S	GvDo....
23cac	USGS Test hole 2043	180	5	Dr	8-1-62	T	Gv	1,930	BR-149, L.
23ccc	A. Nycia	220	2	Dr	1961	74	S	Sd	Wad.
24baa	R. J. Marchant	74	4	Dr	1932	35	D,S	GvDo....
26ddd	E. Nolan	90	2	Dr	1913	60	D,S	Sd & GvDo....
27ada1	R. Celley	56	4.5	Dr	1962	9	D,S	Gv	C, Wad, Wh.
27ada2	..do....	270	2.5	Dr	1952	65	D	Sd	C, Wad, Ws.
27bbb	..do....	200	4.5	Dr	1962	80	S	Sd	Wad, Ws.
27bdd	..do....	45	2.5	Dr	9	S	Sd	Win.

(1)	(2)	(3)	(4)	(5)	(6)	(7)	(8)	(9)	(10)	(11)
<u>144-77</u> (Cont.)										
28ccc	H. Celley	62	2.5	Dr	2	S	Gv	Wad.
28ddd	W. W. Sperry	64.05	3	Dr	34.97	N	Gv
30bab	M. R. Rasmussen	165	3	Dr	1955	20	D,S	Sd	Wad.
32cc	I. Munson	50	24	Dr	1918	42	N	Gv
34ccc	E. Novy	60	6	Dr	1928	40	D,S	Gv	Wad.
36acb	USBR drill hole 35	35	3	Dr	1960	10.9	T	Sd	1,935.5	L.
36bac	USBR drill hole 34	30	3	Dr	1960	14.7	T	Gv	1,939.5	..Do....
36bb	W. M. Ryan	31	44	Du	1933	22	D,S	Sd	Wad.
36bbd	USBR drill hole 33	40	3	Dr	1960	10.6	T	..	1,940.8	L.
<u>144-78</u>										
2ddc	H. Schafer	40	48 x 48	Du	30	N	Wad.
3ccb	J. Anderson	12	48 x 48	Du	1933	11	D,SDo....
3cdd	USGS Test hole 1987	40	5	Dr	6-25-62	T	Sd	1,879.2	BR-24, L.
8baa	B. Schutz	180	3	Dr	1959	63	D,S	Sd	Wad, Wal, Ws.
10bbb	J. L. Anderson	15	48 x 48	Du	1954	13	D,S	Gv	C, Wad, Wh.
12bcc	E. T. Schafer	48.16	24	Dr	9.52	N	Gv
12dcb	G. Zellmer	140	4	Dr	120	D,S	Wad.
14ccc	USBR drill hole 28	25	3	Dr	1960	22.4	T	Gv	1,864.6	L.
14cdc	USBR drill hole 29	30	3	Dr	1960	10	T	Silt	1,855.6	..Do....
15cc	W. Steinart	200	3	Dr	1962	45	S	Sd	Wad, Ws.
15ddd	USBR drill hole 27 A	25	3	Dr	1960	16.6	T	Gv	1,864.6	L.
18ddd	A. Delzer	210	3	Dr	1954	35	D,S	Sd	Wad, Ws.
21aaa	USGS Auger hole 24	80	3	Dr	10-23-62	T	..	1,910	BR-72, L.
21aad	P. Zellmer	117	4	Dr	110	D,S	Wad.
22abb	F. Berquist	100	4	Dr	1920	90Do....

(1)	(2)	(3)	(4)	(5)	(6)	(7)	(8)	(9)	(10)	(11)
<u>144-78 (Cont.)</u>										
22cbc	W. Steinart	150	3	Dr	1956	D,S	Wad, Ws.
22dda	R. Patzner	92	6	Dr	1922	70	D,S	Sd	Wad.
23aa	USBR drill hole 31	30	3	Dr	1960	8.9	T	Silt	1,862.0	L.
23abb	USBR drill hole 30	40	3	Dr	1960	7.5	T	Sd	1,855.6	..Do....
26cdc	USGS Test hole 1989	30	5	Dr	6-26-62	T	Gv	1,844.2	BR-26, L.
27ccc	C. Berndt	13	48 x 48	Du	4	D,S	Gv	Wad, Wh.
28aad	C. Anderson	90	4	Dr	50	D,S	Wad.
32bcb	J. C. Olson	72	18	Dr	1909	58	D,S	Clay	Win.
32daa	J. Gehring	85	6	Dv	80	D,S	Wad.
33aaa	C. Berndt	160	4	Dr	1960	20	S	SdDo....
<u>144-79</u>										
1ccb	USGS Test hole 2051	60	5	Dr	8-1-62	T	Sd	1,821.5	BR-35, L.
2ccb	D. Stelter	20	24	Dr	15	D,S	Sd	Wad, Wal, Wh.
8abb	A. E. Nelson	90	24	Dr	1901	80	S	Gv	Wad.
8bbc	R. Hansen	90	3	Dr	1955	25	D,S	Sd	Wad, Wh.
10ddb	C. Stelter	184	3	Dr	1961	15	D,S	Ss	Wad, Ws.
12dad	F. Bender, Jr.	135	4	Dr	1924	D,S	Sd	Wad, Wal, Ws.
14dd	K. Prockop	20	48 x 48	Du	15	S	Gv	Wad.
18cbc1	E. Wagner	325	2	Dr	1947	185	D,S	Sd	Wad, Ws.
18cbc2	..do....	130	24	Dr	1902	125	S	Sd	Win.
20bba1	H. E. Redington	65	24	Dr	1937	57	S	Sd	Wad.
20bba2	..do....	180	2	Dr	1920	100	SDo....
23bab	V. Bucholz	290	3	Dr	1935	D,S	Sd	Wad, Ws.
24aba	W. Stebert	275	3	Dr	1960	50	D,S	Sd	C, Wad, Ws.
24bb	J. Schaffer	25	24 x 24	Du	20	S	Wad.
24cdc	E. Hochhalter	28	24	Dr	1915	18	S	Gv	Wad, Wh.

(1)	(2)	(3)	(4)	(5)	(6)	(7)	(8)	(9)	(10)	(11)
144-79 (Cont.)										
25bcc	USGS Test hole 1986	75	5	Dr	6-25-62	T	Gv	1,830.8	BR-66, L.
25dd	P. E. Mattis	20	48 x 48	Du	15	S	Sd & Gv	Wad.
26cdd	Unknown	30.07	24	Dr	16.16	N
27dd	F. Lange	104	24	Dr	1903	92	D	Gv	Wad.
29ccb	USGS Test hole 2050	30	5	Dr	8-1-62	T	..	1,801	BR-20, L.
30ada	Hryzckow Bros	250	3	Dr	1959	120	D,S	Sd	Wad, Ws.
30bcc	N. Hall	227	3	Dr	1960	65	D,S	Ss
32cda	J. Kassian	20	24	Dr	1928	12	..	Sd	Wad.
32daa	M. Oschanyk	25	24	Dr	1918	18	S	SdDo....
33bba	J. Hruby	150	4	Dr	GvDo....
33ddd	P. Hruby	80	4	Dr	1926	70	S	SdDo....
34aba	P. Duma	203	3	Dr	1957	53	D,S	Sd	Wad, Ws.
34cdd	P. Hruby	275	3	Dr	1959	D,S	SdDo....

TABLE 2.--Logs of test holes

137-75-8dda
Test hole 1829

<u>Formation</u>	<u>Material</u>	<u>Thickness</u> (feet)	<u>Depth</u> (feet)
Glacial drift:			
	Topsoil, black, sandy-----	5	5
	Till, yellowish-brown, oxidized-----	11	16
	Till, dark-gray, calcareous-----	27	43
	Clay, dark-gray-----	15	58
	Sand, dark-gray, fine to medium-----	3	61
	Gravel, medium; sand, very coarse---	2	63
	Till, gray, silty to sandy, lignite fragments-----	10	73
	Till, olive-gray, silty, lignite smears-----	51	124
Fox Hills Sandstone:			
	Sandstone, greenish-gray, fine-to- medium-grained, clayey, well sort- ed, glauconitic, limonite streaks--	28	152
Pierre Shale:			
	Shale, dark-gray, compact-----	5	157

137-75-17bbb
Test hole 1828

<u>Formation</u>	<u>Material</u>	<u>Thickness</u> (feet)	<u>Depth</u> (feet)
Glacial drift:			
	Roadfill, clay and sand, brown-----	5	5
	Sand, black, clayey, humus-----	5	10
	Clay, brownish-gray, silty-----	11	21
	Clay, medium-gray, lignite chips----	21	42
	Clay, medium to dark-gray-----	62	104
	Gravel, medium; sand, very coarse---	16	120
	Clay, dark-gray, silty-----	27	147
	Gravel, coarse; sand, very coarse---	5	152

TABLE 2.--Logs of test holes -- Continued

137-75-17bbb, Continued
Test hole 1828

<u>Formation</u>	<u>Material</u>	<u>Thickness</u> (feet)	<u>Depth</u> (feet)
Glacial drift-Continued:			
	Sand, gray, fine to medium lignite, fragments-----	16	168
Fox Hills Sandstone:			
	Sandstone, greenish-gray, very fine grained, well-sorted, rounded, very glauconitic; siltstone, dark-gray, minor constituent, interbedded-----	10	178
Pierre Shale:			
	Shale, dark-gray, compact-----	11	189

137-75-31aab
Test hole 2048

<u>Formation</u>	<u>Material</u>	<u>Thickness</u> (feet)	<u>Depth</u> (feet)
Glacial drift:			
	Sand, very fine to medium, silty, unsorted, oxidized-----	4	4
	Clay, moderate-yellowish-brown, silty, cohesive, calcareous, oxidized-----	8	12
	Silt, dark-greenish-gray, clayey, cohesive, mica and lignite flecks, calcareous-----	18	30
Fox Hills Sandstone:			
	Silt, greenish-gray, indurated, sparse lignite fragments-----	15	45

TABLE 2.--Logs of test holes -- Continued

137-76-2bbb
Test hole 2031

<u>Formation</u>	<u>Material</u>	<u>Thickness</u> (feet)	<u>Depth</u> (feet)
Glacial drift:			
	Topsoil-----	1	1
	Clay, moderate-yellowish-brown, silty to sandy, shale pebbles, calcareous, oxidized-----	32	33
	Clay, grayish-orange, silty, co- hesive, calcareous, oxidized-----	10	43
	Clay, dark-greenish-gray, very silty, cohesive, calcareous-----	20	63
	Silt, dark-greenish-gray; sand, very fine to fine; highly- calcareous-----	19	82
	Clay, dark-greenish-gray, very silty, cohesive, highly cal- careous-----	12	94
	Silt, dark-greenish-gray; sand, very fine, highly calcareous-----	32	126
	Clay, dark-greenish-gray, very silty, cohesive, highly- calcareous-----	8	134
	Gravel, fine, sandy, subrounded, unsorted-----	7	141

Fox Hills Sandstone:

	Sand, very fine to fine, clayey, abundant glauconite grains-----	24	165
--	---	----	-----

137-76-8cdd
Glen Adams test hole 3
Log by Schnell, Inc.

<u>Material</u>	<u>Thickness</u> (feet)	<u>Depth</u> (feet)
Topsoil-----	2	2
Sand-----	5	7
Brown clay-----	18	25

TABLE 2.--Logs of test holes -- Continued

137-76-8cdd, Continued
 Glen Adams test hole 3
 Log by Schnell, Inc.

<u>Material</u>	<u>Thickness</u> (feet)	<u>Depth</u> (feet)
Blue clay-----	78	103
Sand-----	25	128
Sandy clay-----	15	143
Sand-----	15	158
Gravel-----	51	209
Large gravel-----	3	212
Clay-----	3	215

137-76-9bbc
 Test hole 1825

<u>Formation</u>	<u>Material</u>	<u>Thickness</u> (feet)	<u>Depth</u> (feet)
Glacial drift:			
	Topsoil, brown, silty to sandy-----	5	5
	Clay, yellowish-brown, hard-----	16	21
	Clay, yellowish-brown, soft-----	73	110
	Sand, fine to medium; gravel, medium to coarse; unsorted, angular to rounded-----	16	126
Fox Hills Sandstone:			
	Shale, medium-gray, silty-----	31	157
	Sandstone, grayish-green, fine-grained, very glauconitic-----	11	168
	Shale, grayish-green, soft, sandy, scattered yellowish-brown shale stringers-----	42	210
	Shale, grayish-brown to green, sandy; sandstone, greenish-gray fine-grained, glauconitic-----	21	231

TABLE 2.--Logs of test holes -- Continued

137-76-9bbc, Continued
Test hole 1825

<u>Formation</u>	<u>Material</u>	<u>Thickness</u> (feet)	<u>Depth</u> (feet)
Pierre Shale:			
	Shale, gray, sandy-----	21	252

137-76-12ddd
Test hole 1827

<u>Formation</u>	<u>Material</u>	<u>Thickness</u> (feet)	<u>Depth</u> (feet)
Glacial drift:			
	Sand, brown, fine to medium, well- rounded, sorted-----	10	10
	Sand, brown to gray, fine to coarse, well-rounded, poorly-sorted-----	11	21
	Sand, brown, fine to medium well- rounded, well-sorted-----	5	26
	Clay, medium-gray, silty-----	5	31
	Clay, medium to dark-gray, cohesive-	16	47
Fox Hills Sandstone:			
	Sandstone, greenish-gray, very fine to fine, well-sorted, well-round- ed, glauconitic-----	26	73

137-76-17aaa
Test hole 1826

<u>Formation</u>	<u>Material</u>	<u>Thickness</u> (feet)	<u>Depth</u> (feet)
Glacial drift:			
	Topsoil, yellowish-brown-----	15	15
	Clay, gray, smooth-----	70	94

TABLE 2.--Logs of test holes -- Continued

137-76-17aaa, Continued
 Test hole 1826

<u>Formation</u>	<u>Material</u>	<u>Thickness</u> (feet)	<u>Depth</u> (feet)
Glacial drift-Continued:			
	Clay, gray, sandy-----	6	100
	Sand, greenish-gray, very fine to fine-----	5	105
	Sand, fine to very coarse-----	21	126
	Sand, fine to medium, shaley-----	5	131
	Clay, gray, silty-----	5	136
	Gravel, medium to coarse; sand, fine to coarse; poorly-sorted, lignite fragments-----	32	168
	Sand, medium to very coarse, gra- velly-----	5	173

137-76-18ccd
 Test hole 2047

<u>Formation</u>	<u>Material</u>	<u>Thickness</u> (feet)	<u>Depth</u> (feet)
Glacial drift:			
	Clay, yellowish-brown, sandy, silty, oxidized-----	5	5
Hell Creek Formation:			
	Clay, dusky-yellow, silty, streaks of leached material, oxidized-----	4	9
	Clay, moderate-olive-brown, silty, slightly-sandy, oxidized-----	8	17
	Clay, medium-bluish-gray, silty; sand, fine to medium; carbon- aceous layers-----	19	36
	Sand, medium-bluish-gray, silty, abundant lignite fragments-----	8	44

TABLE 2.--Logs of test holes -- Continued

137-76-18ccd, Continued
Test hole 2047

<u>Formation</u>	<u>Material</u>	<u>Thickness</u> (feet)	<u>Depth</u> (feet)
Hell Creek Formation-Continued:			
	Clay, brownish-gray, silty, lignite smears; sand, bluish-green, fine-----	10	54
	Clay, medium-bluish-gray, silty, with green sand and lignite fragments-----	3	57
	Shale, olive-gray, very carbonaceous-----	1	58
	Clay, medium-bluish-gray, some sands and lignite fragments-----	6	64
	Sand, bluish-green, carbonaceous streaks, sandstone from 66-77 feet-----	6	70
	Shale, olive-gray to brown-----	4	74
	Clay, medium-bluish-gray, green to gray specks and lignite-----	2	76
	Shale, dusky-brown, carbonaceous-----	4	80
	Shale, olive-black, silty, abundant black carbonaceous plant and other material-----	1	81
	Shale, brownish-black, silty, carbonaceous, compact-----	1/2	81 1/2
	Shale, olive-black, silty, carbonaceous, lignitic layers, marcasite common-----	4 1/2	86
	Shale, olive-black, carbonaceous, lignitic layers, becoming sandy, very fine; scattered celenite crystals-----	1 1/2	87 1/2
	Siltstone, light-gray, clayey-----	2 1/2	90
	Siltstone, medium-dark-gray, clayey, massive, compact-----	3/4	90 3/4
	Siltstone, medium-gray, clayey, compact, massive, thinly-bedded-----	2	92 3/4
	Siltstone, medium-gray, clayey, thin layers of sandstone, friable-----	1/2	93 1/2

TABLE 2.--Logs of test holes -- Continued

137-76-18ccd, Continued
Test hole 2047

<u>Formation</u>	<u>Material</u>	<u>Thickness</u> (feet)	<u>Depth</u> (feet)
Fox Hills Sandstone:			
	Sandstone, medium-gray, with interbedded siltstone, friable----	3/4	94
	Sandstone, medium-bluish-gray, very fine to fine, friable, numerous rounded green grains, glauconitic-----	1	95
	Sandstone, medium-bluish-gray, friable, glauconitic, indurated-----	2 1/2	97 1/2
	Sandstone, dark-greenish-gray, very glauconitic, friable-----	7 1/2	105
	Shale, light-olive-gray, compact, platy-----	1 3/4	106 3/4
	Shale, dark-greenish-gray, silty, compact, sand, very fine-----	1 1/4	108
	Sandstone, medium-bluish-gray, very fine to fine, rounded, silty, glauconitic, friable-----	7	115

137-76-21bbc
Test hole 1824

<u>Formation</u>	<u>Material</u>	<u>Thickness</u> (feet)	<u>Depth</u> (feet)
Fox Hills Sandstone:			
	Sandstone, yellowish-brown, fine-grained, oxidized-----	10	10
	Clay, yellowish-brown, oxidized-----	6	16
	Clay, yellowish-brown; shale, medium-gray, silty; oxidized-----	10	26
	Shale, medium-gray, soft-----	21	47
	Sandstone, light-gray, fine-grained; shale, gray-----	16	63
	Shale, gray, soft, silty to sandy-----	37	100
	Shale, medium-gray, soft-----	5	105

TABLE 2.--Logs of test holes -- Continued

137-76-21bbc, Continued
Test hole 1824

<u>Formation</u>	<u>Material</u>	<u>Thickness</u> (feet)	<u>Depth</u> (feet)
Fox Hills Sandstone- Continued:			
	Shale, medium-gray, silty-----	26	131
	Shale, medium-gray, soft-----	42	173
	Clay, gray; sand, gray, fine-----	16	189
	Sand, light-greenish-gray, fine, clayey, glauconitic-----	5	194
	Clay, light-gray, sandy, benton- itic-----	11	205
	Clay, light-gray, bentonitic, shale, gray, interbedded-----	5	210
	Sand, very fine to fine, rounded, glauconitic; clay, gray, soft (drillers lost circulation at 220')-	21	231
	Clay, greenish-gray, soft, sandy-----	21	252
	Sand, gray, fine, subrounded, shaley--	11	263
Pierre Shale:			
	Clay, gray, soft-----	10	273
	Shale, gray, soft-----	42	315

137-76-35aaa
Test hole 1937

<u>Formation</u>	<u>Material</u>	<u>Thickness</u> (feet)	<u>Depth</u> (feet)
Glacial drift:			
	Topsoil-----	1	1
	Clay, yellowish-gray, very sandy, silty-----	4	5
	Clay, medium-gray, silty to sandy----	36	41
	Clay, medium-gray, silty; sand, coarse, snail shells; interbedded---	22	63

TABLE 2.--Logs of test holes -- Continued

137-76-35aaa, Continued
 Test hole 1937

<u>Formation</u>	<u>Material</u>	<u>Thickness</u> (feet)	<u>Depth</u> (feet)
Glacial drift-Continued:			
	Clay, olive-gray, silty-----	41	104
	Gravel, fine to medium-----	3	107
Fox Hills Sandstone:			
	Sandstone, greenish-gray, indurated, very fine to fine-grained, very glauconitic; shale, medium-gray, silty; interbedded-----	19	126

137-76-36abb
 Test hole 1938

<u>Formation</u>	<u>Material</u>	<u>Thickness</u> (feet)	<u>Depth</u> (feet)
Glacial drift:			
	Clay, light-olive-gray, very sandy, silty-----	10	10
	Clay, dark-greenish-gray, silty-----	10	20
	Sand, medium to coarse-----	2	22
	Clay, dark-greenish-gray, silty, a- bundant snail shells-----	23	45
	Gravel, fine to medium-----	2	47
	Clay, olive-gray, silt, olive-gray---	44	91
	Sand, gray, fine-----	2	93
	Silt, olive-gray, clayey-----	7	100
	Gravel, fine to medium; sand, coarse to very coarse, abundant shale pebbles-----	3	103
	Clay, olive-gray, silty, gravelly----	12	115
	Gravel, fine to medium; sand, coarse to very coarse; abundant shale-----	9	124
	Sand, coarse to very coarse, abundant shale pebbles, well-rounded-----	24	148

TABLE 2.--Logs of test holes -- Continued

137-76-36abb, Continued
Test hole 1938

<u>Formation</u>	<u>Material</u>	<u>Thickness</u> (feet)	<u>Depth</u> (feet)
Glacial drift-Continued:			
	Sand, coarse to very coarse, abundant shale pebbles; clay, olive-gray, silty and sandy; lignite fragments; interbedded-----	31	179
Pierre Shale:			
	Shale, medium-dark-gray, silty-----	20	199

137-77-8ddd
Test hole 1830

<u>Formation</u>	<u>Material</u>	<u>Thickness</u> (feet)	<u>Depth</u> (feet)
Glacial drift:			
	Topsoil, brown, sandy-----	2	2
	Till, yellowish-brown, sandy, oxidized, abundant shale pebbles-----	19	21
	Till, medium-gray, silty to sandy-----	10	31
	Sand, greenish-gray to medium-green, abundant dark-green minerals-----	28	59
Hell Creek Formation:			
	Shale, brown, lignitic; sandstone, greenish-gray, friable-----	4	63
	Shale, greenish-gray, compact, silty; sandstone, medium-gray, very fine grained, friable-----	21	84
	Sandstone, greenish-gray, fine to medium, friable-----	26	110
	Shale, brownish-black, lignitic-----	11	121
	Shale, medium-gray, compact-----	5	126
	Shale, light-greenish-gray, silty, glauconitic (?)-----	5	131

TABLE 2.--Logs of test holes -- Continued

137-77-8ddd, Continued
 Test hole 1830

<u>Formation</u>	<u>Material</u>	<u>Thickness</u> (feet)	<u>Depth</u> (feet)
Glacial drift-Continued:			
	Shale, greenish-gray, lignitic; sandstone, greenish-gray, fine to medium-grained, glauconitic (?)-----	10	141
	Shale, brownish-gray, lignitic-----	11	152
	Shale, medium-gray, silty, compact----	5	157
	Sandstone, dark-greenish-gray, fine- grained, clayey, friable, glau- conitic (?)-----	6	163
	Lignite; shale, brownish-black; in- terbedded-----	6	169
	Shale, brownish-gray, lignitic-----	4	173
Fox Hills Sandstone:			
	Shale, greenish-gray, lignitic (?); sandstone, greenish-gray, friable; interbedded-----	37	210
	Siltstone, greenish-gray; shale, med- ium-gray-----	10	220
	Siltstone, greenish-gray; shale, med- ium-gray; sandstone, medium-gray, very fine-grained-----	16	236
	Sandstone, light-greenish-gray, fine to medium-grained, glauconitic-----	27	263
	Sandstone, light-greenish-gray, fine to medium, glauconitic; shale, light-greenish-gray, silty-----	10	273
	Shale, light-greenish-gray; siltstone, medium-gray-----	5	278
	Shale, light-greenish-gray-----	21	299
	Sandstone, dark-greenish-gray, fine to medium-grained, clayey, friable, glauconitic-----	79	378
	Sandstone, dark-green, abundant glau- conite grains, friable; shale, med- ium-gray; interbedded-----	21	399
	Sandstone, dark-greenish-gray, fine to medium-grained, friable, abun- dant glauconite grains-----	37	436

TABLE 2.--Logs of test holes -- Continued

137-77-8ddd, Continued
Test hole 1830

<u>Formation</u>	<u>Material</u>	<u>Thickness</u> (feet)	<u>Depth</u> (feet)
Fox Hills Sandstone-Continued:			
	Sandstone, very-dark-green, fine to medium-grained, friable, very glauconitic-----	9	445
Pierre Shale:			
	Shale, dark-gray to black-----	48	493

137-77-14ddd
Test hole 1936

<u>Formation</u>	<u>Material</u>	<u>Thickness</u> (feet)	<u>Depth</u> (feet)
Colluvium:			
	Clay, light-olive-gray, silty to very sandy, oxidized-----	7	7
Hell Creek Formation:			
	Claystone, light-olive-brown, silty and sandy, soft, oxidized-----	8	15
	Claystone, brownish-gray, lignitic, soft-----	6	21
	Claystone, grayish-olive, lignitic, soft-----	9	30
	Sandstone, grayish-olive, very fine to fine-grained, silty and clayey, abundant glauconite grains-----	22	52
	Claystone, dark-greenish-gray, silty, soft; sandstone, brownish-gray, friable, silty and clayey-----	6	58
	Sandstone, medium-bluish-gray, very fine to fine-grained, friable, silty, mica flakes-----	9	67
	Sandstone, medium-bluish-gray, very fine-grained, friable, silty-----	7	74

TABLE 2.--Logs of test holes -- Continued

137-77-14ddd, Continued
 Test hole 1936

<u>Formation</u>	<u>Material</u>	<u>Thickness</u> (feet)	<u>Depth</u> (feet)
Hell Creek Formation-Continued:			
	Claystone, brownish-gray, very fine, soft, silty and sandy-----	5	79
	Sandstone, medium-bluish-gray, very fine to fine-grained, friable, silty-----	4	83
	Claystone, olive-gray, soft, silty---	7	90
	Sandstone, dark-greenish-gray, very fine to fine-grained, silty, abundant glauconite grains-----	10	100
	Claystone, brownish-gray, silty, carbonaceous-----	10	110
Fox Hills Sandstone:			
	Sandstone, dark-greenish-gray, friable, very fine to fine-grained, glauconitic-----	11	121
	Claystone, greenish-gray, silty-----	5	126
	Sandstone, dark-greenish-gray, indurated-----	1	127
	Sandstone, dark-greenish-gray, friable, indurated-----	20	147

137-78-8bcb
 Test hole 2014

<u>Formation</u>	<u>Material</u>	<u>Thickness</u> (feet)	<u>Depth</u> (feet)
Glacial drift:			
	Sand, very fine to medium, silty, poorly-sorted, oxidized-----	5	5
	Sand, very fine to medium, silty, unsorted, abundant limestone, calcareous, oxidized-----	11	16
	Clay, dark-greenish-gray; sand, very fine to fine, lignite fragments----	1	17

TABLE 2.--Logs of test holes -- Continued

137-78-8bcb, Continued
Test hole 2014

<u>Formation</u>	<u>Material</u>	<u>Thickness</u> (feet)	<u>Depth</u> (feet)
Glacial drift-Continued:			
	Silt, dark-greenish-gray, clayey to sandy, cohesive, lignite fragments, mica flakes-----	13	30
	Sand, very fine to fine, poorly-sorted, abundant limestone grains, lignite fragments, mica flakes-----	17	47
	Silt, dark-greenish-gray, lignite fragments; sand, very fine to fine, poorly-sorted-----	15	62
	Sand, very fine to fine, poorly-sorted, abundant limestone, some lignite and mica-----	20	82
	Silt, dark-greenish-gray, lignite fragments; sand, very fine to fine, poorly-sorted-----	40	122
	Clay, olive-gray, silty, hard, lignite fragments-----	9	131
	Sand, very fine to very coarse, gravelly, subrounded to well-rounded, abundant limestone, lignite fragments; clay, olive-gray, silty, in thin layers throughout---	85	216

Fox Hills Sandstone:

	Clay, greenish-black, very sandy, abundant glauconite-----	24	240
--	--	----	-----

137-78-17ccc
Test hole 2040

<u>Formation</u>	<u>Material</u>	<u>Thickness</u> (feet)	<u>Depth</u> (feet)
Glacial drift:			
	Topsoil-----	2	2

TABLE 2.--Logs of test holes -- Continued

137-78-17ccc, Continued
Test hole 2040

<u>Formation</u>	<u>Material</u>	<u>Thickness</u> (feet)	<u>Depth</u> (feet)
Glacial drift-Continued:			
	Sand, dark-yellowish-brown, very fine to medium; clay, cohesive; lignite fragments, highly-calcareous-----	13	15
	Sand, very fine to medium, fair sorting, angular to subangular, abundant lignite fragments-----	58	73
	Silt, light-olive-gray, clayey, cohesive, calcareous-----	29	102
	Clay, moderate-yellowish-brown, very sandy, oxidized, highly-calcareous-	10	112
	Sand, dark-greenish-gray, clayey, unsorted, abundant lignite fragments, slightly-calcareous-----	57	169
Fox Hills Sandstone:			
	Clay, dark-greenish-gray, silty, indurated-----	11	180

137-78-22ccc
Test hole 2013

<u>Formation</u>	<u>Material</u>	<u>Thickness</u> (feet)	<u>Depth</u> (feet)
Glacial drift:			
	Sand, fine to medium, well-sorted, angular to subrounded, predominantly quartz, oxidized-----	8	8
	Clay, dark-yellowish-orange, mottled, silty, cohesive, highly-calcareous, partially-oxidized-----	18	26
	Clay, olive-gray, very silty, cohesive, calcareous, occasional oxidized area-----	19	45

TABLE 2.--Logs of test holes -- Continued

137-78-22ccc, Continued
Test hole 2013

<u>Formation</u>	<u>Material</u>	<u>Thickness</u> (feet)	<u>Depth</u> (feet)
Glacial drift-Continued:			
	Clay, olive-gray, silty, very cohesive, calcareous-----	55	100
Fox Hills Sandstone:			
	Sandstone, dusky-yellow, fine-grained, silty, indurated, oxidized-----	2	102
	Sandstone, medium-bluish-gray, very fine to fine-grained, with black and green grains, some mica-----	3	105

137-78-33aba
Test hole 2039

<u>Formation</u>	<u>Material</u>	<u>Thickness</u> (feet)	<u>Depth</u> (feet)
Glacial drift:			
	Topsoil-----	2	2
	Sand, very fine to medium, subangular to subrounded, lignite fragments, calcareous-----	6	8
	Clay, olive-gray, silty, cohesive; sand, very fine to medium, abundant snail shells-----	7	15
	Sand, very fine to medium, clayey, subangular to subrounded, lignite fragments-----	5	20
	Clay, olive-gray, very silty, cohesive, calcareous-----	57	77
	Silt, dark-gray, sandy, abundant lignite fragments, calcareous-----	7	84
	Clay, olive-gray, silty, cohesive, calcareous-----	12	96
	Silt, olive-gray, sandy, lignite fragments, mica flakes, dry-----	9	105

TABLE 2.--Logs of test holes -- Continued

137-78-33aba, Continued
Test hole 2039

<u>Formation</u>	<u>Material</u>	<u>Thickness</u> (feet)	<u>Depth</u> (feet)
Glacial drift-Continued:			
	Clay, dark-greenish-gray, silty, cohesive, hard, slightly calcareous-----	27	132
	Gravel, fine, sandy, unsorted, subrounded, abundant limestone and lignite fragments-----	19	151
	Silt, dark-greenish-gray, sandy, slightly-calcareous-----	6	157
	Sand, dark-greenish-gray, very fine to fine, unsorted, abundant shale and lignite fragments, slightly-calcareous-----	32	189
	Silt, dark-greenish-gray, clayey, cohesive, calcareous-----	15	204
	Sand, very fine to very coarse, gravelly, subrounded to well-rounded, abundant limestone and lignite-----	16	220

Fox Hills Sandstone:

	Sand, grayish-blue-green, very fine to fine, silty, predominantly quartz and green sand grains-----	20	240
--	---	----	-----

137-79-26cbb
Test hole 2015

<u>Formation</u>	<u>Material</u>	<u>Thickness</u> (feet)	<u>Depth</u> (feet)
Glacial drift:			
	Silt, dusky-yellow to moderate-olive-brown, very clayey, lignitic, calcareous, oxidized-----	10	10
	Silt, dark-greenish-gray, clayey, cohesive, lignite fragments-----	6	16

TABLE 2.--Logs of test holes -- Continued

137-79-26cbb, Continued
 Test hole 2015

<u>Formation</u>	<u>Material</u>	<u>Thickness</u> (feet)	<u>Depth</u> (feet)
Glacial drift-Continued:			
	Sand, very fine to medium, unsorted, silty, lignite fragments-----	14	30
	Sand, very fine to medium, unsorted, lignite fragments-----	20	50
	Gravel, fine, sandy to clayey, sub-rounded to well-rounded, abundant carbonates, lignite fragments-----	10	60
	Gravel, fine, sandy, abundant lignite, some snail shells and wood fragments-----	10	70
	Gravel, fine to medium, sandy, sub-rounded to well-rounded, abundant lignite and clay-----	30	100
Fox Hills Sandstone:			
	Clay, dark-greenish-gray, silty, cohesive; sand, very fine to fine----	5	105

137-79-27dd
 G. O'Callaghan, Jr. test hole
 Log by Norman Stal

<u>Material</u>	<u>Thickness</u> (feet)	<u>Depth</u> (feet)
Silt loam topsoil-----	3	3
Yellow silt clay-----	5	8
Sand-----	5	13
Clay layer-----	3	16
Sand-----	12	28
Lignite and sand-----	2	30
Sand with lignite traces-----	12	42
Sand, medium to coarse-----	26	68
Sand, coarse, and fine gravel-----	12	80
Sand, coarse, with lignite-----	15	95

TABLE 2.--Logs of test holes -- Continued

137-80-3abb
Test hole 1852

<u>Formation</u>	<u>Material</u>	<u>Thickness</u> (feet)	<u>Depth</u> (feet)
Alluvium:			
	Roadfill, gravel, sand and clay-----	10	10
	Sand, medium-gray, very fine to fine, clayey-----	11	21
	Sand, dark-gray, fine to medium, rounded, lignite fragments-----	21	42
Hell Creek Formation:			
	Sandstone, greenish-gray, very fine to fine-grained; clay, greenish- gray, silty; interbedded-----	21	63
	Sandstone, light-greenish-gray, fine to medium-grained, glauconitic (?)--	11	74
	Sandstone, greenish-gray, glauconitic (?); shale, brownish-gray, silty, lignitic-----	5	79
	Sandstone, greenish-gray, very fine to fine-grained, silty to clayey, glauconitic (?)-----	5	84

137-80-3dab
Test hole 1851

<u>Formation</u>	<u>Material</u>	<u>Thickness</u> (feet)	<u>Depth</u> (feet)
Alluvium:			
	Topsoil, medium-gray, sandy-----	5	5
	Clay, brown, silty-----	11	16
	Clay, medium-gray, silty-----	5	21
	Sand, medium-gray, very fine to fine, silty-----	10	31

TABLE 2.--Logs of test holes -- Continued

137-80-3dab, Continued
Test hole 1851

<u>Formation</u>	<u>Material</u>	<u>Thickness</u> (feet)	<u>Depth</u> (feet)
Hell Creek Formation:			
	Sandstone, medium to greenish-gray, fine to medium-grained, friable-----	26	57
	Shale, medium-gray, silty; sandstone, greenish-gray, fine-grained, friable, abundant dark grains-----	6	63

137-80-24abc
Test hole 1949

<u>Formation</u>	<u>Material</u>	<u>Thickness</u> (feet)	<u>Depth</u> (feet)
Glacial drift:			
	Clay, pale-yellowish-brown, silty, cohesive, oxidized, calcareous-----	11	11
	Clay, light-olive-gray, silty, very cohesive, lignitic, calcareous-----	10	21
	Sand, very fine to coarse, unsorted, subrounded to rounded, abundant lignite fragments, scattered snail shells-----	60	81
	Gravel, fine to medium, sandy, un- sorted, subangular to subrounded, lignite fragments-----	9	90
	Gravel, fine to coarse, sandy, sub- rounded to well-rounded, abundant brown pebbles, lignite fragments----	14	104
	Sand, medium to very coarse, gravelly, subrounded, lignite fragments, a- bundant brown grains-----	11	115
Fox Hills Sandstone:			
	Clay, bluish-gray, silty-----	11	126

TABLE 2.--Logs of test holes -- Continued

138-75-5ddd
Test hole 2046

<u>Formation</u>	<u>Material</u>	<u>Thickness</u> (feet)	<u>Depth</u> (feet)
Glacial drift:			
	Till, moderate-olive-brown, oxidized-----	50	50
	Till, moderate-olive-brown, sandy, contains lignite smears, oxidized-----	16	66
	Till, light-olive-gray, sandy-----	27	93
	Till, medium-dark-gray-----	31	122

Hell Creek Formation:

	Sand, grayish-green, fine to medium, clayey, with brown carbonaceous particles-----	14 1/2	136 1/2
--	---	--------	---------

138-75-8cdd
Test hole 2021

<u>Formation</u>	<u>Material</u>	<u>Thickness</u> (feet)	<u>Depth</u> (feet)
Glacial drift:			
	Till, moderate-yellowish-brown, lignite fragments, oxidized, highly calcareous-----	55	55
	Till, dark-yellowish-orange, highly-oxidized-----	13	68
	Till, dark-greenish-gray, silty, lignite fragments, calcareous-----	23	91
	Till, olive-gray, silty, lignite fragments, calcareous-----	13	104

TABLE 2.--Logs of test holes -- Continued

138-75-8cdd, Continued
Test hole 2021

<u>Formation</u>	<u>Material</u>	<u>Thickness</u> (feet)	<u>Depth</u> (feet)
Hell Creek Formation:			
	Sandstone, dark-yellowish-orange, fine-grained, silty, oxidized-----	4	108
	Sandstone, yellowish-brown, partially- oxidized-----	6	114
	Sandstone, greenish-gray, abundant glauconite-----	6	120

138-75-9bcb
Auger hole 18

<u>Formation</u>	<u>Material</u>	<u>Thickness</u> (feet)	<u>Depth</u> (feet)
Glacial drift:			
	Topsoil, dusky-yellow-----	2	2
	Clay, moderate-olive-brown, silty, thinly-bedded-----	8	10
	Till, olive-gray, oxidized-----	6	16

138-75-16bbb
Auger hole 17

<u>Formation</u>	<u>Material</u>	<u>Thickness</u> (feet)	<u>Depth</u> (feet)
Glacial drift:			
	Topsoil, brownish-gray, sandy to gravelly-----	2	2
	Clay, yellowish-gray, silty, very thinly-bedded-----	10	12
	Clay, moderate-yellowish-brown silty, thinly bedded-----	3	15
	Till, moderate-yellowish-brown, oxi- dized-----	7	22

TABLE 2.--Logs of test holes -- Continued

138-75-20aaa
Test hole 2025

<u>Formation</u>	<u>Material</u>	<u>Thickness</u> (feet)	<u>Depth</u> (feet)
Glacial drift:			
	Clay, light-olive-gray, cohesive, scattered carbonaceous particles-----	20	20
	Till, olive-gray, scattered lignite fragments, abundant shale pebbles, oxidized-----	88	108
	Till, medium-bluish-gray, abundant shale pebbles, thin interbedded gravel layers-----	25	137
	Gravel, fine to medium, abundant shale and limestone pebbles-----	8	145
	Till, medium-bluish-gray, abundant shale and limestone pebbles-----	28	173

Fox Hills Sandstone:

	Sand, moderate-yellowish-brown, very fine to fine, silty to clayey, black carbonaceous particles, oxidized-----	26 1/2	199 1/2
--	---	--------	---------

138-76-7add
Test hole 1942

<u>Formation</u>	<u>Material</u>	<u>Thickness</u> (feet)	<u>Depth</u> (feet)
Glacial drift:			
	Clay, dark-yellowish-brown, silty, cohesive, oxidized, calcareous-----	6	6
	Clay, moderate-yellowish-brown, silty, cohesive, oxidized, calcareous-----	11	17
	Clay, light-olive-gray, silty to sandy, cohesive, calcareous-----	20	37
	Gravel, fine to medium, sandy, unsorted, rounded, abundant shale pebbles and lignite fragments-----	11	48

TABLE 2.--Logs of test holes -- Continued

138-76-7add, Continued
Test hole 1942

<u>Formation</u>	<u>Material</u>	<u>Thickness</u> (feet)	<u>Depth</u> (feet)
Glacial drift-Continued:			
	Clay, light-olive-gray, silty, cohesive, calcareous-----	2	50
	Gravel, fine to medium, unsorted, sandy, rounded, abundant shale and lignite-----	2	52
	Sand, fine to coarse, poorly-sorted, subrounded, abundant shale and lignite-----	22	74
	Sand, coarse to very coarse, poorly-sorted, angular, abundant shale and lignite grains-----	6	80
	Sand, greenish-gray, very fine to fine, lignitic in places-----	42	122
	Gravel, medium, well-sorted, sub-angular to well-rounded-----	5	127

Hell Creek Formation:

	Sandstone, medium-bluish-gray to greenish-gray, fine to medium, oxidized, lignite specks; shale, moderate-yellowish-brown, silty----	20	147
--	--	----	-----

138-76-8abb
U.S.B.R. drill hole 27

<u>Material</u>	<u>Thickness</u> (feet)	<u>Depth</u> (feet)
Topsoil, black, organic sandy clay----	1.5	1.
Clay, brown, plastic, stiff, moist (Lacustrine?)-----	24.5	26
Clay, gray, plastic, soft, moist, (Lacustrine?)-----	6	32
Sand, gray, fine, with fine to medium gravels, dense-----	8	40

TABLE 2.--Logs of test holes -- Continued

138-76-8bab
U.S.B.R. drill hole 26

<u>Material</u>	<u>Thickness</u> (feet)	<u>Depth</u> (feet)
Topsoil, black, organic, sandy clay-----	2	2
Clay, brown, plastic, soft-----	14	16
Clay, gray, plastic, soft-----	12	28
Sand and gravel, fairly well graded sand, silty, clayey lenses, with fine to medium gravels-----	7	35

138-76-19abb
Auger hole 11

<u>Formation</u>	<u>Material</u>	<u>Thickness</u> (feet)	<u>Depth</u> (feet)
Glacial drift:			
	Topsoil, dusky-yellowish-brown-----	2	2
	Sand, moderate-brown, fine to medium-----	7	9
	Clay, moderate-yellowish-brown, plastic-----	14	23
	Clay, moderate-yellowish-brown, silty, plastic-----	7	30
	Clay, light-olive-gray, silty, plastic-----	20	50
	Sand, fine to medium-----	2	52
	Clay, light-olive-gray, plastic, cohesive-----	9	61
	Sand, fine to medium-----	3	64
	Clay, light-olive-gray, sandy-----	31	95
	Gravel, fine to medium; sand, coarse--	6	101
	Clay, light-olive-gray, plastic-----	6	107

TABLE 2.--Logs of test holes -- Continued

138-76-19a
 Clyde Monroe test hole 1
 Log by Schnell Inc.

<u>Material</u>	<u>Thickness</u> (feet)	<u>Depth</u> (feet)
Topsoil-----	2	2
Sand-----	4	6
Brown clay (caving)-----	18	24
Blue clay-----	19	43
Fine gravel-----	10	53
Clay-----	5	58
Coarse gravel-----	11	69
Clay-----	1	70

Remarks: Water samples taken at 63 feet.

138-76-19b
 Clyde Monroe test hole 2
 Log by Schnell, Inc.

<u>Material</u>	<u>Thickness</u> (feet)	<u>Depth</u> (feet)
Topsoil-----	4	4
Brown clay-----	24	28
Blue clay-----	48	76
Sand-----	2	78
Clay, gray-----	22	100

138-77-20aaa
 Test hole 1867

<u>Formation</u>	<u>Material</u>	<u>Thickness</u> (feet)	<u>Depth</u> (feet)
Glacial drift:			
	Sand, yellowish-brown, very fine to fine, very clayey, oxidized-----	11	11
	Clay, yellowish-brown, silty-----	4	15
	Clay, light-brownish-gray, silty-----	6	21

TABLE 2.--Logs of test holes -- Continued

138-76-20aaa, Continued
Test hole 1867

<u>Formation</u>	<u>Material</u>	<u>Thickness</u> (feet)	<u>Depth</u> (feet)
Glacial drift-Continued:			
	Clay, medium-gray, silty, lignite fragments-----	31	52
	Clay, light-brownish-gray, silty-----	11	63
	Clay, light-brownish-gray, silty, lignite fragments-----	41	104
	Gravel, medium; sand, very coarse-----	6	110
	Clay, light-brownish-gray, silty-----	40	150
	Gravel, medium; sand, very coarse-----	1	151
	Clay, light-brownish-gray, silty-----	20	171

Fox Hills Sandstone:

	Shale, medium-gray, silty, carbon- aceous streaks-----	18	189
	Shale, medium-gray, silty; sandstone, dark-greenish-gray, very fine to fine-grained, friable, glauconitic--	42	231

138-76-20bbb
Auger hole 12

<u>Formation</u>	<u>Material</u>	<u>Thickness</u> (feet)	<u>Depth</u> (feet)
Glacial drift:			
	Clay, moderate-yellowish-brown; sand, fine to coarse; oxidized-----	10	10
	Clay, moderate-yellowish-brown, plastic, silty, oxidized-----	8	18
	Gravel, fine to coarse-----	4	22
	Sand, fine to coarse-----	39	61
	Clay, light-olive-gray; sand, fine to medium-----	10	71
	Gravel, medium-----	12	83
	Clay, light-olive-gray, sandy-----	4	87

TABLE 2.--Logs of test holes -- Continued

138-76-26aaa
Test hole 2032

<u>Formation</u>	<u>Material</u>	<u>Thickness</u> (feet)	<u>Depth</u> (feet)
Glacial drift:			
	Topsoil, black-----	1	1
	Till, dark-yellowish-orange, abundant limestone and shale pebbles, lignite fragments, calcareous, oxidized-----	17	18
	Gravel, fine to coarse, sandy, unsorted, subangular to subrounded, abundant limestone pebbles-----	8	26
	Clay, dark-greenish-gray, silty, cohesive, calcareous-----	8	34
	Till, dark-greenish-gray, lignite fragments, calcareous-----	36	70
Fox Hills Sandstone:			
	Sandstone, dark-yellowish-orange, fine to very fine-grained, clayey, oxidized-----	4	74
	Sandstone, medium-bluish-gray, fine to very fine-grained, with clay and lignite-----	16	90

138-76-31aab
Test hole 2029

<u>Formation</u>	<u>Material</u>	<u>Thickness</u> (feet)	<u>Depth</u> (feet)
Glacial drift:			
	Roadfill-----	5	5
	Clay, light-olive-gray, silty, highly-calcareous, oxidized-----	12	17
	Clay, dark-gray, very silty, cohesive, lignite fragments-----	10	27
	Silt, medium-bluish-gray, cohesive, abundant lignite chips, few fossils, highly-calcareous-----	8	35

TABLE 2.--Logs of test holes -- Continued

138-76-31aab, Continued
Test hole 2029

<u>Formation</u>	<u>Material</u>	<u>Thickness</u> (feet)	<u>Depth</u> (feet)
Glacial drift-Continued:			
	Silt, moderate-olive-brown, hard, fossil fragments, calcareous, oxidized-----	7	42
	Silt, light-olive-gray, cohesive, lignite flecks, calcareous, oxidized-----	20	62
	Silt, olive-gray, occasional greenish-black areas, cohesive, tiny lignite flecks-----	72	134
	Sand, very fine to coarse, clayey to gravelly, unsorted, subangular, lignite fragments-----	24	158
	Gravel, medium to very coarse; boulders; angular to subrounded-----	8	164
Fox Hills Sandstone:			
	Clay, dark-greenish-gray, silty, indurated, mica flecks-----	16	180

138-76-33bbb
Test hole 2022

<u>Formation</u>	<u>Material</u>	<u>Thickness</u> (feet)	<u>Depth</u> (feet)
Glacial drift:			
	Topsoil-----	1 1/2	1 1/2
	Silt, moderate-yellowish-brown, clayey, cohesive, abundant lignite flecks, oxidized, highly-calcareous-----	9 1/2	11
	Silt, light-olive-gray, very clayey, cohesive, lignite flecks, calcareous	20	31
	Silt, dark-greenish-gray, cohesive, very calcareous-----	59	90

TABLE 2.--Logs of test holes -- Continued

138-76-33bbb, Continued
Test hole 2022

<u>Formation</u>	<u>Material</u>	<u>Thickness</u> (feet)	<u>Depth</u> (feet)
Glacial drift-Continued:			
	Gravel, fine, sandy, unsorted, angular to rounded, abundant shale-----	21	111
Fox Hills Sandstone:			
	Sand, dusky-yellow-green, fine to very fine, silty, some black and green grains-----	3	114
	Sand, olive-black, fine to very fine, abundant lignite, some mica flakes-----	3	117
	Clay, dark-greenish-gray, silty, mica and lignite flakes-----	3	120

138-76-36aaa
Auger hole 16

<u>Formation</u>	<u>Material</u>	<u>Thickness</u> (feet)	<u>Depth</u> (feet)
Glacial drift:			
	Topsoil, brown-----	1	1
	Till, moderate-yellowish-brown, oxidized-----	23	24
	Till, olive-gray, sandy-----	52	76
	Sand, olive-gray, fine to medium, saturated, poorly-sorted, abundant shale-----	13	89
	Sand, olive-gray, very poorly sorted, very coarse to medium, gravelly-----	23	112

TABLE 2.--Logs of test holes -- Continued

138-77-2abb, Continued
Auger hole 7

<u>Formation</u>	<u>Material</u>	<u>Thickness</u> (feet)	<u>Depth</u> (feet)
Glacial drift:			
	Topsoil, yellowish-brown-----	2	2
	Till, light-brown, shale pebbles, oxidized-----	3	5
	Sand, light-brown, fine to medium, oxidized-----	1	6
	Clay, moderate-yellowish-brown, with gray streaks, plastic, a few scat- tered lignite smears, oxidized-----	12	18
	Clay, moderate-yellowish-brown, silty--	10	28
	Gravel, fine to medium-----	1	29
	Till, moderate-yellowish-brown, sandy--	10	38
	Sand, moderate-yellowish-brown, fine to medium-----	4	42
	Clay, moderate-yellowish-brown-----	4	46
	Sand, moderate-yellowish-brown, fine to medium, clayey-----	19	65
Hell Creek Formation:			
	Clay, dark-greenish-gray, sandy; sand, fine to medium-----	12	77

138-77-3abb
Auger hole 8

<u>Formation</u>	<u>Material</u>	<u>Thickness</u> (feet)	<u>Depth</u> (feet)
Glacial drift:			
	Topsoil, black-----	2	2
	Clay, moderate-yellowish-brown; sand, fine to medium; oxidized-----	8	10
	Clay, grayish-brown; sand, fine to medium-----	4	14
	Clay, light-olive-gray; sand, fine to medium-----	13	27
	Clay, light-olive-gray, plastic, co- hesive-----	5	32

TABLE 2.--Logs of test holes -- Continued

138-77-3ccd
Test hole 1944

<u>Formation</u>	<u>Material</u>	<u>Thickness</u> (feet)	<u>Depth</u> (feet)
Glacial drift:			
	Topsoil, black-----	1	1
	Clay, moderate-yellowish-brown, silty, cohesive, oxidized, calcareous-----	23	24
	Clay, light-olive-gray, silty, cohesive, oxidized, calcareous-----	57	81
	Gravel, fine to coarse, sandy, sub-angular to rounded, unsorted-----	3	84
	Clay, light-olive-gray, silty, cohesive, calcareous-----	29	113
	Sand, medium to coarse, sorted, angular, abundant shale and lignite fragments-----	43	156
	Sand, coarse to very coarse, gravelly, poorly-sorted, subangular to rounded, abundant shale and lignite fragments-----	22	178
Fox Hills Sandstone:			
	Shale, dark-greenish-gray, silty, indurated-----	11	189

138-77-4acc
U.S.B.R. drill hole 21

<u>Material</u>	<u>Thickness</u> (feet)	<u>Depth</u> (feet)
Topsoil, brown, clayey-----	1.5	1.5
Clay, brown and gray, plastic, fairly stiff, with trace of silt (lacustrine)	24.5	26
Clay, gray, silty, plastic, soft lacustrine-----	9	35
Clay, gray, silty, plastic, soft becoming stiff at 60' (lacustrine)-----	65	100

TABLE 2.--Logs of test holes -- Continued

138-77-4adc
U.S.B.R. drill hole 22

<u>Material</u>	<u>Thickness</u> (feet)	<u>Depth</u> (feet)
Clay, brown and gray, plastic, trace of silt (lacustrine)-----	27	27
Clay, gray, silty, soft, sticky (lacustrine)-----	5	32
Sand, gray, very fine, silty-----	5	37
Clay, gray, silty, plastic (lacustrine)	8	45
Clay, gray, moderately plastic, stiff (lacustrine)-----	25	70

138-77-4add
U.S.B.R. drill hole 23

<u>Material</u>	<u>Thickness</u> (feet)	<u>Depth</u> (feet)
Topsoil, black, organic, clayey-----	1	1
Clay, grayish-brown, silty, stiff, plastic, (lacustrine)-----	25	26
Silt, gray, with thin sand and clay zones-----	5	31
Clay, gray, silty, plastic, stiff (lacustrine)-----	16	47
Sand, gray, fine, silty, soft-----	8	55
Clay, gray, stiff, very plastic (lacustrine)-----	14	69
Sand, brown, fine to coarse, dense----	1	70

138-77-5cbb
U.S.B.R. drill hole 18

<u>Material</u>	<u>Thickness</u> (feet)	<u>Depth</u> (feet)
Topsoil, brown, organic, sandy clay---	3	3
Clay, brown, plastic, stiff, moist----	8	11
Sand, tan, very fine, dry, trace of silt-----	10	21
Sand and gravel, brown, coarse sand with fine to medium gravel, silty, clayey-----	14	35

TABLE 2.--Logs of test holes -- Continued

138-77-5dab
U.S.B.R. drill hole 20

<u>Material</u>	<u>Thickness</u> (feet)	<u>Depth</u> (feet)
Topsoil, black, organic clay-----	1.5	1.5
Clay, brown, plastic, stiff, gypsum concentrations throughout-----	10.5	12
Sand, brown, fine, silty, soft-----	5	17
Clay, brown, plastic, soft-----	6	23
Clay, gray, very plastic, soft be- coming stiff at approx. 47'-----	37	60

Note: Above materials are of lacustrine origin.

138-77-5dbb
U.S.B.R. drill hole 19

<u>Material</u>	<u>Thickness</u> (feet)	<u>Depth</u> (feet)
Topsoil, black, organic clay-----	2	2
Clay, brown, plastic, stiff, gypsum concentrations throughout (lacust- rine)-----	21	23
Clay, gray, plastic, stiff (lacust- rine)-----	4	27
Clay (till?), gray, sandy, soft, with fine gravels throughout-----	22.5	49.5
Clay, gray, plastic, stiff (lacust- ine)-----	10.5	60

138-77-6ccd
U.S.B.R. drill hole 15

<u>Material</u>	<u>Thickness</u> (feet)	<u>Depth</u> (feet)
Clay, gray, firm, occasional gravels---	3	3
Clay, brown, soft, plastic, with con- centrations of gypsum-----	8	11
Sand, brown, fine, silty, soft-----	6	17

TABLE 2.--Logs of test holes -- Continued

138-77-6ccd, Continued
U.S.B.R. drill hole 15

<u>Material</u>	<u>Thickness</u> (feet)	<u>Depth</u> (feet)
Clay, gray, soft, plastic-----	14	31
Sand, gray, fine, silty, soft-----	5.5	36.5
Clay, gray, soft, plastic-----	18	54.5
Sand, gray, medium to coarse, with fine gravels, clayey-----	5.4	59.8

Note: Above materials from 0 to 54.5' are of lacustrine origin.

138-77-6cda
U.S.B.R. drill hole 16

<u>Material</u>	<u>Thickness</u> (feet)	<u>Depth</u> (feet)
Topsoil, brown, organic, silty, clay--	1.5	1.5
Clay, brown, soft, plastic-----	14.5	16
Clay, gray, soft, plastic-----	6	22
Sand, gray, fine, very silty, soft----	5	27
Clay, gray, plastic, soft to stiff----	33	60

Note: Above materials are of lacustrine origin.

138-77-6daa
Test hole 1945

<u>Formation</u>	<u>Material</u>	<u>Thickness</u> (feet)	<u>Depth</u> (feet)
Glacial drift:			
	Topsoil, black-----	1	1
	Clay, dark-yellowish-brown, silty, calcareous-----	27	28
	Sand, coarse to very coarse, gravelly, abundant shale particles-----	8	36

TABLE 2.--Logs of test holes -- Continued

138-77-6daa, Continued
Test hole 1945

<u>Formation</u>	<u>Material</u>	<u>Thickness</u> (feet)	<u>Depth</u> (feet)
Glacial drift-Continued:			
	Sand, gray, medium to very coarse, poorly-sorted, abundant shale and lignite-----	17	53
	Sand, medium to very coarse; gravel, fine to medium; silty to clayey, abundant lignite fragments-----	6	59
	Gravel, medium to coarse, sandy, abundant lignite fragments -----	5	64
Hell Creek Formation:			
	Shale, grayish-brown, silty, carbonaceous-----	8	72
	Shale, greenish-gray, silty to sandy-----	12	84

138-77-6dbd
U.S.B.R. drill hole 17

<u>Material</u>	<u>Thickness</u> (feet)	<u>Depth</u> (feet)
Clay, brown, soft, sandy in zones, gypsum concentrations throughout----	21	21
Clay, gray, plastic, soft to stiff----	39	60

Note: Above materials are of lacustrine origin.

TABLE 2.--Logs of test holes -- Continued

138-77-9bdb
Test hole 1831

<u>Formation</u>	<u>Material</u>	<u>Thickness</u> (feet)	<u>Depth</u> (feet)
Glacial drift:			
	Topsoil, black, sandy-----	5	5
	Sand, yellowish-brown, very fine to fine, clayey-----	5	10
	Clay, yellowish-brown, silty-----	21	31
	Clay, medium-gray-----	12	43
	Clay, medium-gray; sand, very coarse; abundant shale pebbles-----	5	48
	Clay, medium-gray, silty-----	76	124
	Sand, medium-gray, fine to medium, clayey, lignite fragments-----	29	153
Hell Creek Formation:			
	Shale, medium-gray, silty, lignitic----	5	158
Fox Hills Sandstone:			
	Shale, medium-gray, silty-----	37	195
	Sandstone, dark-greenish-gray, fine to medium-grained, glauconitic; shale, medium-gray, silty; interbedded----	25	220
	Sandstone, greenish-gray, fine to medium-grained, clayey, friable, abundant quartz grains-----	11	231

138-77-10d
Bill McDonald test hole 1
Log by Schnell Inc.

<u>Material</u>	<u>Thickness</u> (feet)	<u>Depth</u> (feet)
Topsoil-----	2	2
Sand-----	4	6
Brown clay-----	11	17
Blue clay-----	81	98
Gravel-----	10	108

TABLE 2.--Logs of test holes -- Continued

138-77-10d, Continued
 Bill McDonald test hole 1
 Log by Schnell Inc.

<u>Material</u>	<u>Thickness</u> (feet)	<u>Depth</u> (feet)
Sandy clay-----	14	122
Sand-----	24	146
Coal-----	1	147
Gravel-----	6	153
Sand-----	7	160

138-77-10dca
 Bill McDonald test hole 6
 Log by Schnell Inc.

<u>Material</u>	<u>Thickness</u> (feet)	<u>Depth</u> (feet)
Brown clay-----	35	35
Blue clay-----	61	96
Sand-----	5	101
Clay-----	6	107
Sand-----	33	140
Coarse gravel-----	15	155
Fine gravel-----	5	160

138-77-10dcd
 Bill McDonald test hole 5
 Log by Schnell Inc.

<u>Material</u>	<u>Thickness</u> (feet)	<u>Depth</u> (feet)
Sand-----	6	6
Brown clay-----	18	24
Blue clay-----	83	107
Gravel-----	2	109
Clay-----	25	136
Fine sand-----	15	151
Coarse gravel-----	18	169
Medium gravel-----	29	198

TABLE 2. Logs of test holes -- Continued

138-77-11aaa
 Test hole 1943

<u>Formation</u>	<u>Material</u>	<u>Thickness</u> (feet)	<u>Depth</u> (feet)
Glacial drift:			
	Topsoil, black-----	1	1
	Clay, moderate-yellowish-brown, silty, cohesive, oxidized, calcareous-----	15	16
	Sand, fine to very coarse; gravel, fine to coarse; angular to sub- rounded, oxidized-----	3	19
	Clay, moderate-yellowish-brown, silty, cohesive, oxidized, calcareous-----	8	27
	Sand, fine to coarse, poorly-sorted, subangular to well-rounded, a- bundant shale pebbles-----	3	30
	Clay, light-olive-gray, silty, co- hesive, calcareous-----	7	37
	Sand, fine to coarse, poorly-sorted, subangular to well-rounded, silty, cohesive-----	2	39
	Clay, light-olive-gray, silty, co- hesive, calcareous-----	51	90
Hell Creek Formation:			
	Shale, brownish-gray, silty, lignitic--	20	110
	Sandstone, dark-yellowish-orange, very fine to medium-grained, silty, clayey, oxidized-----	6	116
	Sandstone, light-bluish-gray, very fine to medium-grained, oxidation spots-----	10	126

TABLE 2.--Logs of test holes -- Continued

138-77-13aaa
Test hole 2028

<u>Formation</u>	<u>Material</u>	<u>Thickness</u> (feet)	<u>Depth</u> (feet)
Glacial drift:			
	Silt, yellowish-gray, sandy, slightly, cohesive, calcareous, oxidized-----	3	3
	Silt, moderate-yellowish-brown, cohesive, calcareous, oxidized-----	4	7
	Silt, medium-bluish-gray, sandy, cohesive, calcareous-----	4	11
	Silt, olive-gray, very cohesive, calcareous-----	33	44
	Sand, fine to very coarse, gravelly, unsorted, rounded-----	7	51
	Silt, dark-greenish-gray; sand, very fine; lignite fragments, calcareous--	41	92
	Gravel, fine to coarse, sandy, unsorted, subangular, abundant lignite fragments-----	8	100
Hell Creek Formation:			
	Sandstone, dusky-yellow, very fine to fine-grained, clayey, indurated, oxidized-----	15 1/2	115 1
	Sandstone, medium-bluish-gray, fine-grained, clayey, indurated-----	4 1/2	120

138-77-14add
Test hole 1940

<u>Formation</u>	<u>Material</u>	<u>Thickness</u> (feet)	<u>Depth</u> (feet)
Glacial drift:			
	Topsoil, black-----	1	1
	Clay, pale-yellowish-brown, silty, cohesive, oxidized, calcareous-----	8	9
	Clay, dark-yellowish-orange, silty, cohesive, oxidized, calcareous-----	16	25

TABLE 2.--Logs of test holes -- Continued

138-77-14add, Continued
Test hole 1940

<u>Formation</u>	<u>Material</u>	<u>Thickness</u> (feet)	<u>Depth</u> (feet)
Glacial drift-Continued:			
	Clay, pale-yellowish-brown, silty, cohesive, oxidized, calcareous-----	5	30
	Clay, light-olive-gray, silty, cohesive, calcareous-----	31	61
	Gravel, fine to medium, sandy, unsorted, angular to subrounded, abundant carbonates-----	3	64
	Clay, light-olive-gray, silty, cohesive, calcareous-----	66	130
	Sand, very fine to coarse, subangular to rounded, abundant shale and lignite pebbles-----	31	161
	Sand, coarse to very coarse; gravel, granule; unsorted, rounded, abundant quartz and lignite-----	5	166
	Clay, light-olive-gray, silty, cohesive, calcareous-----	7	173
	Sand, fine to coarse, poorly-sorted, angular to rounded, lignite fragments, snail shells-----	27	200
	Gravel, fine to medium, clayey, subangular to rounded; sand, coarse to very coarse, mostly quartz; abundant brown granules, lignite and shell fragments-----	31	231

TABLE 2.- Logs of test holes -- Continued

138-77-14ccc
Test hole 1941

<u>Formation</u>	<u>Material</u>	<u>Thickness</u> (feet)	<u>Depth</u> (feet)
Glacial drift:			
	Topsoil, black-----	2	2
	Clay, dark-yellowish-brown, very silty, oxidized, calcareous-----	9	11
	Clay, moderate-yellowish-brown, silty, cohesive, oxidized, calcareous-----	16	27
	Clay, dark-yellowish-brown, silty, cohesive, oxidized, calcareous-----	5	32
	Clay, light-olive-gray, silty, cohesive, calcareous-----	69	101
	Gravel, fine to medium, subangular to rounded; sand, fine to very coarse; lignite fragments-----	13	114
	Sand, medium to very coarse, well-sorted, angular to rounded, shale granules, lignite fragments-----	12	126
Fox Hills Sandstone:			
	Sand, medium-bluish-gray, very fine to fine, silty, biotite flakes-----	10	136

138-77-15aaa
Test hole 2023

<u>Formation</u>	<u>Material</u>	<u>Thickness</u> (feet)	<u>Depth</u> (feet)
Glacial drift:			
	Topsoil-----	1	1
	Sand, very fine to fine, silty, poorly-sorted, subrounded-----	15	16
	Sand, very fine to very coarse, silty, unsorted, subrounded to well-rounded-----	3	19
	Silt, dark-greenish-gray, clayey, calcareous-----	13	32
	Clay, light-olive-gray, silty, cohesive, lignite flecks-----	80	112
	Silt, olive-gray, clayey, some laminations, calcareous-----	18	130

TABLE 2.--Logs of test holes -- Continued

138-77-15aaa, Continued
Test hole 2023

<u>Formation</u>	<u>Material</u>	<u>Thickness</u> (feet)	<u>Depth</u> (feet)
Glacial drift-Continued:			
	Gravel, fine, sandy, unsorted, lignite fragments-----	1	131
	Sand, very fine to very coarse, unsorted, subrounded to well-rounded, lignite fragments-----	16	147
	Gravel, fine to coarse, sandy, unsorted, rounded, abundant limestone and granitic rocks-----	13	160
	Gravel, fine to medium, unsorted, subrounded, predominantly shale, abundant limestone and lignite-----	29	189
	Silt, olive-gray, clayey, abundant lignite fragments-----	15	204
	Gravel, fine to medium, sandy unsorted, rounded, abundant red, green and brownish pebbles (preglacial ?)-----	9	213
Fox Hills Sandstone:			
	Clay, dark-greenish-gray, silty, indurated, mica flakes-----	12	225

138-77-15bbb
Auger hole 13

<u>Formation</u>	<u>Material</u>	<u>Thickness</u> (feet)	<u>Depth</u> (feet)
Glacial drift:			
	Topsoil, moderate-brown, silty-----	1	1
	Clay, moderate-yellowish-brown, silty, plastic, oxidized-----	21	22
	Clay, light-olive-gray, silty-----	11	33
	Clay, light-olive-gray; sand, fine to medium-----	16	49

TABLE 2.--Logs of test holes -- Continued

138-77-15bbb, Continued
Auger hole 13

<u>Formation</u>	<u>Material</u>	<u>Thickness</u> (feet)	<u>Depth</u> (feet)
Glacial drift-Continued:			
	Sand, fine to medium-----	4	53
	Clay, light-olive-gray, sandy-----	59	112

138-77-15caa
Bill Anderson test hole 1
Log by Schnell Inc.

<u>Material</u>	<u>Thickness</u> (feet)	<u>Depth</u> (feet)
Topsoil-----	2	2
Sand-----	3	5
Clay, brown-----	26	31
Clay, blue-----	67	98
Sand-----	11	109
Clay-----	3	112
Coal-----	2	114
Sand-----	25	139
Gravel-----	5	144
Clay-----	6	150

138-77-15dcb
Bill Anderson Irrigation well 1
Log by Schnell Inc.

<u>Material</u>	<u>Thickness</u> (feet)	<u>Depth</u> (feet)
Topsoil-----	3	3
Sand-----	4	7
Clay, brown-----	26	33
Clay, blue-----	75	108
Sand and gravel-----	28	136
Coal-----	1	137
Clay-----	3	140

TABLE 2.--Logs of test holes -- Continued

138-77-22aad
Test hole 1955

<u>Formation</u>	<u>Material</u>	<u>Thickness</u> (feet)	<u>Depth</u> (feet)
Glacial drift:			
	Topsoil, black-----	1	1
	Clay, yellowish-brown, silty, oxidized-----	39	40
	Clay, olive-gray, silty-----	49	89
	Gravel, medium to coarse; sand, coarse to very coarse; abundant lignite and shale fragments-----	5	94
	Sand, gray, fine to medium, gravelly, lignite and shale fragments-----	12	106
	Sand, fine to medium; gravel, fine to medium; abundant lignite and shale fragments-----	8	114
	Gravel, medium to coarse, abundant lignite and shale granules-----	8	122
Fox Hills Sandstone:			
	Sandstone, greenish-gray, very fine to fine, silty, friable-----	4	126

138-77-22bdd
Bill Anderson test hole 5
Log by Schnell Inc.

<u>Material</u>	<u>Thickness</u> (feet)	<u>Depth</u> (feet)
Topsoil-----	2	2
Sand-----	2	4
Clay, brown-----	29	33
Clay, blue-----	10	43
Gravel-----	1	44
Clay, sandy-----	6	50
Clay, black-----	5	55
Shale-----	75	130

TABLE 2.--Logs of test holes -- Continued

138-77-22cac
 Bill Anderson test hole 6
 Log by Schnell Inc.

<u>Material</u>	<u>Thickness</u> (feet)	<u>Depth</u> (feet)
Topsoil-----	2	2
Sand-----	4	6
Clay, brown-----	11	17
Sand-----	14	31
Clay, blue-----	18	49
Clay, sandy-----	7	56
Clay-----	50	106
Sand-----	3	109
Gravel-----	5	114
Clay-----	16	130

138-77-22dda
 Auger hole 15

<u>Formation</u>	<u>Material</u>	<u>Thickness</u> (feet)	<u>Depth</u> (feet)
Glacial drift:			
	Clay, moderate-yellowish-brown, plastic, silty, oxidized-----	21	21
	Clay, moderate-brown, silty, plastic-----	12	33
	Clay, light-olive-gray, silty, plastic-----	56	89
	Sand, fine to very coarse; gravel, fine to medium-----	21	110

TABLE 2.--Logs of test holes -- Continued

138-77-23aac
Test hole 1979

<u>Formation</u>	<u>Material</u>	<u>Thickness</u> (feet)	<u>Depth</u> (feet)
Glacial drift:			
	Topsoil, black, silty to sandy-----	2	2
	Sand, fine to medium, oxidized-----	12	14
	Clay, yellowish-brown, silty to sandy, cohesive, unoxidized beyond 20 feet-----	8	22
	Clay, gray, silty, cohesive-----	28	50
	Sand, fine to medium, abundant lignite	1/2	50 1/2
	Clay, olive-gray, silty, cohesive, lignite flakes-----	50 1/2	101
	Gravel, fine to coarse, cobbles; sand, very coarse; subangular to rounded, lignite fragments-----	18	119
	Lignite-----	1	120
	Sand, fine to coarse, subrounded-----	2	122
Hell Creek (?) Formation:			
	Clay, grayish-brown, very sandy-----	8	130

138-77-23ddb
Ray Baeth Irrigation well 1
Log by Ben Hasz

<u>Material</u>	<u>Thickness</u> (feet)	<u>Depth</u> (feet)
Topsoil-----	2	2
Sand-----	5	7
Brown clay-----	21	28
Blue clay-----	48	76
Fine gravel-----	22	98
Coarse gravel-----	9	107
Fine gray sand-----	2	109
Sandy gray clay-----	6	115

TABLE 2.--Logs of test holes -- Continued

138-77-23ddb2
Baeth Screen test

<u>Formation</u>	<u>Material</u>	<u>Thickness</u> (feet)	<u>Depth</u> (feet)
Glacial drift:			
	Topsoil, dark-brown-----	1	1
	Clay, yellowish-brown, oxidized-----	7	8
	Clay, yellowish-brown, silty, slightly-oxidized-----	19	27
	Clay, olive-gray, silty to sandy, cohesive, calcareous-----	28	55
	Clay, light-olive-gray, silty, cohesive, dense, calcareous-----	17	72
	Sand, coarse to granule, sub- rounded, abundant lignite and shale-----	6	78
	Gravel, coarse to very coarse, rounded-----	5	83
	Lignite-----	1	84
	Gravel, coarse to very coarse; sand, medium to very coarse, subrounded-----	6	90

138-77-23ddb3
Baeth pumping observation test hole

<u>Formation</u>	<u>Material</u>	<u>Thickness</u> (feet)	<u>Depth</u> (feet)
Glacial drift:			
	Topsoil, brownish-black, sandy-----	2	2
	Clay, yellowish-brown, silty, co- hesive, oxidized, calcareous-----	19	21
	Clay, medium to olive-gray, silty, cohesive, calcareous-----	49	70
	Sand, yellowish-gray, fine, gravelly, abundant lignite and shale fragments	10	80
	Gravel, coarse to very coarse; sand, coarse; subrounded-----	27	107

TABLE 2.--Logs of test holes -- Continued

138-77-24bbb
Auger hole 14

<u>Formation</u>	<u>Material</u>	<u>Thickness</u> (feet)	<u>Depth</u> (feet)
Glacial drift:			
	Sand, moderate-yellowish-brown, fine to medium, oxidized-----	5	5
	Clay, moderate-yellowish-brown; sand fine to medium; oxidized-----	6	11
	Clay, moderate-yellowish-brown, silty, oxidized-----	13	24
	Clay, grayish-brown, silty-----	14	38
	Clay, light-olive-gray, silty-----	16	54
	Sand, fine to medium, clayey-----	6	60
	Clay, light-olive-gray, silty; sand, fine-----	8	68
	Sand, fine to medium-----	9	77
	Clay, light-olive-gray, silty-----	14	91
	Gravel, fine to coarse; sand, medium to coarse-----	21	112

138-77-24ccc
Test hole 1939

<u>Formation</u>	<u>Material</u>	<u>Thickness</u> (feet)	<u>Depth</u> (feet)
Glacial drift:			
	Topsoil, brown-----	1	1
	Sand, light-olive-gray, fine to medium, silty and clayey-----	5	6
	Clay, light-olive-gray, and pale-yellowish-brown, silty and sandy----	10	16
	Clay, light-olive-gray to medium-gray, smooth-----	1	17
	Clay, light-olive-gray, silty, cohesive-----	48	65
	Gravel, fine to very coarse, abundant lignite, shale, igneous and carbonate pebbles-----	23	88
	Clay, olive-gray, silty; sand, very coarse; shale fragments-----	17	105

TABLE 2.--Logs of test holes -- Continued

138-77-24ccc, Continued
 Test hole 1939

<u>Formation</u>	<u>Material</u>	<u>Thickness</u> (feet)	<u>Depth</u> (feet)
Glacial drift-Continued:			
	Clay, olive-gray, very silty, sandy---	52	157
	Clay, olive-gray, very silty, sandy to gravelly-----	3	160
Fox Hills Formation:			
	Sandstone, medium-light-gray, very fine to fine-grained, friable; shale, medium-light-gray-----	8	168

138-77-24dcc
 Auger hole 9

<u>Formation</u>	<u>Material</u>	<u>Thickness</u> (feet)	<u>Depth</u> (feet)
Glacial drift:			
	Topsoil, dusky-brown, sandy-----	1	1
	Sand, light-olive-gray, fine to med- ium, becoming more clayey from 10 - 15 feet-----	19	20
	Sand, olive-gray, clayey, fine to medium-----	9	29
	Clay, light-olive-gray; sand, fine to medium-----	41	70
	Clay, olive-gray, dense, harder drill- ing than above-----	18	88
	Clay, olive-gray, plastic, cohesive---	24	112

TABLE 2.--Logs of test holes -- Continued

138-77-24dd
Auger hole 10

<u>Formation</u>	<u>Material</u>	<u>Thickness</u> (feet)	<u>Depth</u> (feet)
Glacial drift:			
	Topsoil, moderate-yellowish-brown, sandy-----	2	2
	Clay, moderate-yellowish-brown, silty; sand, fine-----	28	30
	Clay, moderate-yellowish-brown, silty-----	4	34
	Clay, light-olive-gray, silty, plastic, cohesive-----	38	72
	Clay, olive-gray, silty, plastic, cohesive-----	30	102

138-77-25a
Bill McDonald test hole 3
Log by Schnell Inc.

<u>Material</u>	<u>Thickness</u> (feet)	<u>Depth</u> (feet)
Topsoil-----	3	3
Sand-----	7	10
Brown clay-----	10	20
Blue clay-----	65	85
Gravel-----	1	86
Sandy clay-----	14	100

TABLE 2.--Logs of test holes -- Continued

138-77-25bbd2
Adams Screen test

<u>Formation</u>	<u>Material</u>	<u>Thickness</u> (feet)	<u>Depth</u> (feet)
Glacial drift:			
	Topsoil, black, sandy-----	1	1
	Clay, yellowish-brown, silty, cal- careous, oxidized-----	17	18
	Clay, olive-gray, cohesive, cal- careous-----	35	53
	Gravel, fine to very coarse, sub- rounded; sand, fine to coarse; abundant shale and carbonates-----	27	80

138-77-25d
Bill McDonald test hole 2
Log by Schnell Inc.

<u>Material</u>	<u>Thickness</u> (feet)	<u>Depth</u> (feet)
Topsoil-----	2	2
Sand-----	6	8
Brown clay-----	13	21
Blue clay-----	18	39
Gravel-----	9	48
Clay-----	9	57
Gravel-----	2	59
Clay-----	1	60

138-77-25daa
Bill McDonald service well
Log by Schnell, Inc.

<u>Material</u>	<u>Thickness</u> (feet)	<u>Depth</u> (feet)
Topsoil-----	1	1
Sand-----	15	16
Brown clay-----	8	24
Blue clay-----	5	29
Gravel-----	27	56

TABLE 2.--Logs of test holes -- Continued

138-77-26adc
 Test hole 1954

<u>Formation</u>	<u>Material</u>	<u>Thickness</u> (feet)	<u>Depth</u> (feet)
Glacial drift:			
	Topsoil, black-----	1	1
	Clay, dark-yellowish-orange, silty, cohesive, lignite fragments, oxi- dized, calcareous-----	19	20
	Clay, dark-yellowish-brown, silty, cohesive, lignite fragments, oxi- dized, calcareous-----	5	25
	Clay, olive-gray, silty, cohesive, lignite fragments, calcareous-----	8	33
	Gravel, fine to coarse, sandy, subrounded, unsorted-----	8	41
	Sand, very fine to coarse, silty, unsorted, subangular to rounded, abundant shale and lignite frag- ments-----	12	53
	Sand, coarse to very coarse; gravel, granule; poorly sorted, subangular to well rounded-----	5	58
	Gravel, fine; sand, fine to very coarse; unsorted, subrounded, lig- nite and shale pebbles-----	5	63
	Clay, olive-gray, silty to sandy-----	11	74
Hell Creek Formation:			
	Shale, light-bluish-gray, silty to sandy-----	4 3/4	78 3/4

TABLE 2.--Logs of test holes -- Continued

138-77-26dda
Test hole 1869

<u>Formation</u>	<u>Material</u>	<u>Thickness</u> (feet)	<u>Depth</u> (feet)
Glacial drift:			
	Topsoil, black-----	1	1
	Clay, yellowish-brown, silty-----	20	21
	Clay, light to medium-gray, silty to sandy. lignite fragments-----	42	63
	Clay, medium-brownish-gray, silty---	41	104
	Sand, medium to very coarse-----	11	115
	Gravel, medium to coarse; sand, medium to very coarse-----	9	124
	Clay, medium-gray, silty-----	13	137
	Clay, medium-gray, silty; sand, gray, fine to medium-----	11	148
	Sand, gray, fine to medium, silty, gravelly, lignite fragments; clay, medium-gray; interbedded-----	20	168
	Sand, medium to very coarse; gravel, fine to medium-----	11	179
Fox Hills Sandstone:			
	Sandstone, greenish-gray, very fine to fine-grained, silty and clayey, abundant glauconite-----	4	183
	Sandstone, greenish-gray, very fine to fine-grained, silty and clayey, glauconitic; shale, medium gray, silty and sandy-----	7	192
	Sandstone, greenish-gray, silty and clayey, friable, abundant glau- conite, some specks of carbonaceous material-----	18	210
	Sandstone, greenish-gray, friable, glauconitic, indurated; shale, medium to greenish-gray; silty-----	21	231

TABLE 2.--Logs of test holes -- Continued

138-77-32d~~aa~~
 Test hole 1868

<u>Formation</u>	<u>Material</u>	<u>Thickness</u> (feet)	<u>Depth</u> (feet)
Glacial drift:			
	Topsoil, black and dark-brown-----	2	2
	Till, brown and buff, sandy, shale pebbles, lignite smears-----	20	22
Hell Creek Formation:			
	Shale, dark-brownish-gray; silty, very carbonaceous-----	5	27
	Shale, brown, silty-----	4	31
	Sandstone, yellowish-brown, fine to medium-grained, friable, clayey, abundant dark minerals-----	6	37
	Sandstone, light-brownish-gray, fine to medium-grained, friable, clayey----	5	42
	Shale, medium-gray, silty and sandy; sandstone, light-bluish-gray, very fine to fine-grained, glauconitic; interbedded-----	5	47
	Shale, brownish-gray to medium-gray, carbonaceous; sandstone, medium to light-greenish-gray, very fine to fine-grained, glauconitic-----	37	84
	Shale, green to dark-grayish-brown, silty, lignite seams interbedded----	16	100
	Shale, dark-grayish-brown, silty very carbonaceous; sandstone, greenish-gray, very fine to fine- grained, friable, silty to clayey, glauconitic-----	5	105
	Sandstone, dark-greenish-gray, very fine to fine-grained, friable, silty and clayey-----	11	116
	Sandstone, dark-greenish-gray, very fine to fine-grained, friable; shale, grayish-brown, carbonaceous, silty; interbedded-----	10	126
	Shale, dark-grayish-brown, silty, a- bundant lignite and peat-----	10	136

TABLE 2.--Logs of test holes -- Continued

138-77-32daa, Continued
Test hole 1868

<u>Formation</u>	<u>Material</u>	<u>Thickness</u> (feet)	<u>Depth</u> (feet)
Fox Hills Sandstone:			
	Sandstone, light-bluish and light-greenish-gray, friable, silty and clayey, glauconitic, some indurated layers-----	32	168
	Shale, light to medium-gray, silty, carbonaceous streaks-----	31	199
	Sandstone, light-bluish and light-greenish-gray, friable, silty and clayey, glauconitic-----	11	210

138-77-35bbb
Test hole 2030

<u>Formation</u>	<u>Material</u>	<u>Thickness</u> (feet)	<u>Depth</u> (feet)
Glacial drift:			
	Sand, very fine to fine, silty, unsorted, oxidized-----	10	10
	Silt, dark-yellowish-orange, cohesive, lignite flecks, oxidized----	25	35
	Sand, fine to medium	1/2	35 1/2
	Clay, dark-greenish-gray, silty, cohesive, calcareous-----	4 1/2	40
Hell Creek Formation:			
	Sand, very fine to fine, silty, lignite fragments, oxidized-----	11	51
	Sand, medium-bluish-gray, very fine to fine, clayey, abundant glauconite grains-----	4	55
	Clay, olive-gray, silty, lignite fragments, indurated-----	5	60

TABLE 2.--Logs of test holes -- Continued

138-78-1abb
 Test hole 1952

<u>Formation</u>	<u>Material</u>	<u>Thickness</u> (feet)	<u>Depth</u> (feet)
Glacial drift:			
	Topsoil, black-----	1	1
	Clay, light-olive-gray; sand, fine to medium; calcareous-----	5	6
	Clay, pale-yellowish-brown, calcareous-----	10	16
	Clay, dusky-brown, silty, calcareous	4	20
	Clay, olive-gray, silty, lignite fragments, calcareous-----	26	46
	Clay, olive-gray, silty, calcareous--	68	114
	Sand, olive-gray, fine to medium, silty, poorly-sorted, calcareous---	11	125
	Gravel, fine, sandy, poorly-sorted, subrounded to rounded; clay, olive-gray, silty; abundant shale pebbles, interbedded-----	31	156
	Sand, fine to coarse, angular to subrounded, shale and lignite fragments, rounded; clay, olive-gray, very silty, calcareous-----	16	172
	Clay, light-olive-gray, very silty, lignite fragments, calcareous-----	16	188
	Gravel, fine, sandy, subrounded to rounded, unsorted, lignite fragments-----	10	198
Fox Hills Sandstone:			
	Clay, light-olive to greenish-gray, silty to sandy, calcareous-----	12	210

TABLE 2.--Logs of test holes -- Continued

138-78-1ddd
U.S.B.R. drill hole 14

<u>Material</u>	<u>Thickness</u> (feet)	<u>Depth</u> (feet)
Clay, gray, plastic, firm, numerous concentrations of gypsum and probable alkaline salts -----	6	6
Clay, gray and brown, soft, plastic, occasional salt concentrations -----	6	12
Sand, brown, fine, very silty, soft-----	5	17
Clay, gray, silty, soft, moderately plastic, silty and sandy 30' to 52' with silt and sand content decreasing 52' to 60'-----	43	60

Note: Above materials of lacustrine origin.

138-78-2cdd
U.S.B.R. drill hole 12

<u>Material</u>	<u>Thickness</u> (feet)	<u>Depth</u> (feet)
Clay (glacial till), brown, sandy, with gravels throughout, occasional boulders -----	3	3
Sand, tan, fine, dry, dense (Fort Union Group)-----	15	18
Clay (shale), gray, very firm, dry-----	6.7	24.7

138-78-7cbb
Test hole 1946

<u>Formation</u>	<u>Material</u>	<u>Thickness</u> (feet)	<u>Depth</u> (feet)
Glacial drift:			
	Topsoil, black-----	3	3
	Clay, light-olive-gray, silty, calcareous -----	13	16

TABLE 2.--Logs of test holes -- Continued

138-78-7cbb, Continued
Test hole 1946

<u>Formation</u>	<u>Material</u>	<u>Thickness</u> (feet)	<u>Depth</u> (feet)
Glacial drift-Continued:			
	Clay, grayish-black, silty-----	6	22
	Clay, dark-greenish-gray, silty, calcareous-----	3	25
	Clay, light-olive-gray, silty, calcareous-----	7	32
	Clay, olive-gray, silty to sandy in parts, lignite fragments, cal- careous-----	68	100
	Silt, olive-gray, clayey, sandy, lignite fragments, calcareous-----	30	130
	Gravel, medium to coarse; sand, medium to very coarse; poorly- sorted, clayey, lignite and shale pebbles-----	5	135
	Silt, gray; clay, gray; sand, fine; lignite fragments-----	35	170
	Gravel, medium to coarse; sand, very coarse-----	14	184

Fox Hills Sandstone:

	Siltstone, olive-gray, clayey, slightly calcareous-----	8	192
	Shale, olive-gray, silty-----	6	206
	Sandstone, dusky-blue-green, very fine to fine-grained, friable, silty, very glauconitic-----	14	220

138-78-19abb
Test hole 1948

<u>Formation</u>	<u>Material</u>	<u>Thickness</u> (feet)	<u>Depth</u> (feet)
Glacial drift:			
	Topsoil, black-----	3	3
	Clay, dark-yellowish-orange, silty, cohesive, oxidized, calcareous----	15	18

TABLE 2.--Logs of test holes -- Continued

138-78-19abb, Continued
Test hole 1948

<u>Formation</u>	<u>Material</u>	<u>Thickness</u> (feet)	<u>Depth</u> (feet)
Glacial drift-Continued:			
	Clay, dark-yellowish-brown, silty, cohesive, lignite fragments, oxidized, calcareous-----	7	25
	Sand, very fine to medium, very angular to rounded, lignite fragments-----	13	38
	Clay, light-olive-gray, cohesive, lignite fragments, calcareous-----	22	60
Hell Creek Formation:			
	Sand, medium-bluish-gray, very fine to medium, silty, abundant lignite, shale and green grains; shale, brownish-gray, interbedded--	24	84

138-78-21ccc
Test hole 2041

<u>Formation</u>	<u>Material</u>	<u>Thickness</u> (feet)	<u>Depth</u> (feet)
Glacial drift:			
	Topsoil, black-----	2	2
	Sand, dusky-yellowish-brown, fine to medium, unsorted, oxidized-----	6	8
	Sand, very fine to medium, poorly-sorted-----	13	21
	Silt, dark-greenish-gray, clayey to sandy, cohesive, lignite flecks, calcareous-----	31	52
	Clay, dark-greenish-gray, silty, lignite flecks, cohesive-----	4	56
	Silt, dark-greenish-gray, clayey, to sandy, cohesive, lignite flecks, calcareous-----	27	83

TABLE 2.-- Logs of test holes -- Continued

138-78-21ccc, Continued
Test hole 2041

<u>Formation</u>	<u>Material</u>	<u>Thickness</u> (feet)	<u>Depth</u> (feet)
Hell Creek Formation:			
	Sandstone, medium-bluish-gray, very fine to fine, silty, soft, lignite fragments-----	22	105

138-78-23aaa
Test hole 1947

<u>Formation</u>	<u>Material</u>	<u>Thickness</u> (feet)	<u>Depth</u> (feet)
Glacial drift:			
	Topsoil, black----	1	1
	Clay, medium-light-gray, silty to sandy, cohesive, oxidized, calcareous-----	5	6
	Clay, dark-yellowish-orange, silty, cohesive, oxidized, calcareous----	7	13
	Clay, light-olive-gray, very silty, cohesive, calcareous-----	6	19
	Silt, light-olive-gray, clayey, sandy, calcareous-----	25	44
	Clay, light-olive-gray, silty, cohesive, calcareous-----	70	114
	Clay, light-olive-gray, silty, cohesive; sand, very fine to coarse, unsorted, angular; abundant shale and lignite fragments-----	10	124
	Sand, fine to medium, well-sorted, subangular to well-rounded, shale pebbles-----	33	157
	Gravel, fine to medium, sandy, angular to rounded-----	16	173
Fox Hills Sandstone:			
	Clay, light-bluish-gray, silty to sandy-----	5	178

TABLE 2.--Logs of test holes -- Continued

138-78-23bbb
Test hole 1870

<u>Formation</u>	<u>Material</u>	<u>Thickness</u> (feet)	<u>Depth</u> (feet)
Glacial drift:			
	Topsoil, black-----	1	1
	Clay, dark-gray, silty-----	10	11
	Clay, brownish-gray, silty-----	4	15
	Clay, yellowish-brown, silty-----	6	21
	Clay, medium-brownish-gray, silty--	15	36
	Clay, medium-brownish-gray, silty, lignite fragments-----	27	63
	Clay, medium-brownish-gray, silty--	41	104
	Sand, medium to very coarse; gravel, medium to coarse; clayey, lignite fragments-----	23	127
	Gravel, medium to coarse; sand, med- ium to coarse-----	5	132
Hell Creek Formation:			
	Sandstone, light-greenish-gray, very fine to fine-grained, friable, silty to clayey, glauconitic (?)-----	12	144
	Shale, light-brown, silty-----	4	148
Fox Hills Sandstone:			
	Sandstone, light-greenish-gray, very fine to fine-grained, friable, slightly silty and clayey, glau- conitic (?)-----	10	158
	Shale, brownish-gray, silty, carbon- aceous streaks-----	10	168
	Shale, brownish-gray and medium- gray-----	15	183
	Shale, brownish-gray, and medium- gray, silty and sandy, scattered brown carbonaceous specks-----	37	220
	Shale, dark-gray; sandstone at 231 feet, indurated-----	11	231

TABLE 2.--Logs of test holes -- Continued

138-78-27ccd
 Test hole 2042

<u>Formation</u>	<u>Material</u>	<u>Thickness</u> (feet)	<u>Depth</u> (feet)
Glacial drift:			
	Topsoil, black-----	2	2
	Clay, medium-light-gray, very sandy, cohesive, highly-calcareous-----	4	6
	Sand, fine to coarse, fair sorting, angular to rounded, lignite frag- ments, oxidized-----	4	10
	Sand, medium-light-gray, angular to rounded, abundant lignite frag- ments-----	20	30
	Sand, fine to medium, fair sorting, angular to rounded, abundant lig- nite-----	74	104
	Clay, olive-gray, silty, cohesive, lignite fragments, calcareous-----	32	136
	Sand, fine to very coarse, granular, unsorted, angular to rounded, lig- nite fragments-----	8	144
	Clay, olive-gray, silty, cohesive---	4	148
	Gravel, fine, sandy, unsorted-----	6	154
	Clay, olive-gray, silty, cohesive---	6	160
	Sand, medium, silty-----	6	166
	Silt, olive-gray, clayey-----	4	170
	Sand, medium-----	2	172
	Silt, dark-greenish-gray, clayey, sandy-----	15	187
	Clay, dark-greenish-gray, silty, cohesive-----	11	198
	Gravel, fine to medium, sandy, un- sorted, very angular to rounded, lignite and shale pebbles-----	22	220
Fox Hills Sandstone:			
	Clay, dark-greenish-gray, silty to sandy, cohesive, indurated-----	10	230

TABLE 2.--Logs of test holes -- Continued

138-78-32daa
Test hole 2012

<u>Formation</u>	<u>Material</u>	<u>Thickness</u> (feet)	<u>Depth</u> (feet)
Glacial drift:			
	Silt, dark-yellowish-orange, clayey, cohesive, highly-calcareous-----	9	9
	Sand, fine to medium, sorted, rounded, abundant lignite-----	13	22
	Clay, dark-greenish-gray, silty, cohesive, calcareous, very small lignite and mica flakes-----	10	32
	Silt, dark-greenish-gray, sandy, highly-calcareous, abundant lignite fragments-----	21	53
	Silt, olive-gray, clayey to sandy, lignite and mica flakes-----	9	62
	Sand, very fine to fine, silty, abundant carbonates, some glauconite and lignite fragments-----	68	130
	Clay, olive-gray, silty, lignite flecks-----	11	141
	Sand, very fine to very coarse, very granular, unsorted, angular to rounded, abundant limestone and lignite-----	13	154
	Silt, dark-greenish-gray, clayey to sandy, lignite chips, calcareous---	34	178
	Gravel, fine to medium, sandy, subrounded, unsorted, abundant limestone, few lignite fragments--	9	187
	Silt, dark-greenish-gray to olive-gray, clayey to sandy, cohesive, sparse lignite flecks, calcareous--	9	196
	Gravel, fine to medium, sandy, subrounded, unsorted, abundant limestone, some lignite-----	2 1/2	198 1/2
Fox Hills Sandstone:			
	Silt, olive-gray, indurated, small laminations, abundant green grains-	11 1/2	210

TABLE 2.--Logs of test holes -- Continued

138-79-2aaa
Test hole 2053

<u>Formation</u>	<u>Material</u>	<u>Thickness</u> (feet)	<u>Depth</u> (feet)
Glacial drift:			
	Topsoil, black-----	1	1
	Clay, moderate-yellowish-brown, silty, highly-calcareous-----	11	12
	Sand, very fine to medium, angular to rounded; clay layers, grayish- orange, very silty, highly-cal- careous-----	14	26
	Till, moderate-yellowish-brown, silty, calcareous, oxidized-----	8	34
	Gravel, fine, very sandy, unsorted, subangular to subrounded-----	2	36
	Silt; moderate-yellowish-orange, lignite particles, highly-cal- careous, oxidized-----	12	48
	Silt, greenish to dark-greenish-gray, calcareous, soft, sandy, a- bundant lignite and shale frag- ments-----	14	62

Hell Creek Formation:

	Sandstone, light-olive-gray, very fine to fine-----	3	65
	Silt, dark-gray, clayey, indurated, lignite chips; sand, very fine----	10	75

138-79-3cac
Auger hole 5

<u>Formation</u>	<u>Material</u>	<u>Thickness</u> (feet)	<u>Depth</u> (feet)
Glacial drift:			
	Topsoil, brownish-black-----	2	2
	Clay, moderate-yellowish-brown, oxidized-----	5	7
	Till, moderate-yellowish-brown, sandy, shale pebbles, oxidized----	30	37

TABLE 2.--Logs of test holes -- Continued

138-79-3cac, Continued
Auger hole 5

<u>Formation</u>	<u>Material</u>	<u>Thickness</u> (feet)	<u>Depth</u> (feet)
Glacial drift-Continued:			
	Clay, brownish-gray, sandy-----	12	49
	Clay, olive-gray, sandy-----	15	64
	Sand, greenish-gray, clayey-----	43	107

138-79-8aaa
Test hole 1860

<u>Formation</u>	<u>Material</u>	<u>Thickness</u> (feet)	<u>Depth</u> (feet)
Glacial drift:			
	Topsoil, black-----	2	2
	Clay, yellowish-brown, silty and sandy-----	9	11
	Clay, brownish-gray, cohesive-----	10	21
	Clay, medium-gray, silty and sandy--	11	32
	Sand, light-gray, very fine to fine, silty-----	11	43
	Silt, dark-gray, clayey-----	14	57
	Gravel, medium to coarse, abundant lignite and shale pebbles-----	6	63
	Clay, medium-gray, very sandy-----	5	68
	Sand, light-to-medium-gray, very fine to medium, poorly-sorted, silty, abundant lignite fragments-	16	84
	Clay, medium-gray, silty, lignite fragments-----	21	105
	Sand, light-gray, very fine to fine, silty, to clayey, poorly-sorted---	11	116

TABLE 2.--Logs of test holes -- Continued

138-79-8aaa, Continued
 Test hole 1860

<u>Formation</u>	<u>Material</u>	<u>Thickness</u> (feet)	<u>Depth</u> (feet)
Hell Creek Formation:			
	Shale, brownish-gray, silty, very carbonaceous to lignitic-----	2	118
	Shale, brownish-gray, silty and sandy, carbonaceous streaks-----	5	123
	Shale, medium-gray, silty and sandy, carbonaceous; sandstone, medium-gray, very fine to fine-grained---	3	126
	Shale, light to medium-gray, silty--	5	131
	Shale, greenish to brownish-gray, silty and sandy, carbonaceous streaks; sandstone, greenish-gray, friable, glauconitic (?)----	10	141
	Sandstone, light to bluish-gray, silty to clayey, friable, glauconitic (?)-----	6	147
	Shale, brownish-gray, carbonaceous, abundant lignite (Peat like material)-----	5	152
Fox Hills (?) Sandstone:			
	Sandstone, light-greenish-gray, very fine to fine-grained, silty to clayey, glauconite (?) grains; lignite-----	6	158

TABLE 2.--Logs of test holes -- Continued

138-79-9abb
Test hole 1861

<u>Formation</u>	<u>Material</u>	<u>Thickness</u> (feet)	<u>Depth</u> (feet)
Glacial drift:			
	Topsoil, black-----	2	2
	Clay, yellowish-brown, silty-----	14	16
	Sand, dark-gray, fine to medium, very fossiliferous (pelecypod and gastropod shells), lignite fragments-----	6	22
	Clay, medium-gray, fossil and lig- nite fragments-----	4	26
	Clay, greenish-gray, silty and sandy-----	13	39
	Gravel, medium; sandy, very coarse-----	4	43
	Clay, medium-gray, silty-----	5	48
	Sand, gray to brown, fine to coarse, poorly-sorted-----	5	53
	Sand, light-gray, fine to medium, silty, poorly-sorted-----	27	80
	Gravel, medium to very coarse; sand, very coarse; abundant lignite fragments-----	25	105

TABLE 2.--Logs of test holes -- Continued

138-79-19dcd
Auger hole 4

<u>Formation</u>	<u>Material</u>	<u>Thickness</u> (feet)	<u>Depth</u> (feet)
Glacial drift:			
	Sand, moderate-yellowish-brown, very fine, oxidized-----	3	3
	Clay, moderate-yellowish-brown, plastic, oxidized-----	14	17

138-79-20ccc
Auger hole 3

<u>Formation</u>	<u>Material</u>	<u>Thickness</u> (feet)	<u>Depth</u> (feet)
Glacial drift:			
	Sand, moderate-yellowish-brown very fine to medium-----	1	1
	Clay, moderate-yellowish-brown, plastic-----	6	7

TABLE 2.--Logs of test holes -- Continued

138-80-1dcc
Auger hole 1

<u>Formation</u>	<u>Material</u>	<u>Thickness</u> (feet)	<u>Depth</u> (feet)
Glacial drift:			
	Clay, brownish-gray, plastic, sand, very fine, silty-----	12	12
	Clay, bluish-gray, plastic, silty; sand, very fine-----	14	26
	Clay, dark-greenish-gray, smooth, plastic, cohesive-----	21	47
	Clay, olive-gray; sand, very fine, silty-----	5	52
	Sand, fine to medium, clayey-----	32	84
	Gravel, very coarse; sand, fine to coarse, (rough drilling)-----	8	92
	Clay, olive-gray, smooth-----	5	97

TABLE 2.--Logs of test holes -- Continued

138-80-2bbc
Test hole 2058

<u>Formation</u>	<u>Material</u>	<u>Thickness</u> (feet)	<u>Depth</u> (feet)
Glacial drift:			
	Topsoil, brown, sandy-----	2	2
	Clay, very dark-yellowish-brown, silty and sandy, oxidized, cal- careous-----	9	11
	Sand, dark-yellowish-brown, sub- rounded to rounded, well-sorted, oxidized-----	20	31
	Clay, olive-gray, silty, with very fine sand, smooth, plastic, micaceous, calcareous-----	16	47
Hell Creek Formation:			
	Clay, light-olive-gray to light- greenish-gray, some lignite, very micaceous, smooth, cohesive-	47	84

138-80-2ccc
Test hole 2057

<u>Formation</u>	<u>Material</u>	<u>Thickness</u> (feet)	<u>Depth</u> (feet)
Glacial drift:			
	Topsoil, brownish-black, sandy-----	1	1
	Sand, brown, oxidized, fine to medium, some coarse, sub- rounded, well-sorted, calcar- eous-----	14	15
	Clay, moderate-olive-brown, silty, smooth, plastic, highly cal- careous-----	4	19

TABLE 2.--Logs of test holes -- Continued

138-80-2ccc, Continued
 Test hole 2057

<u>Formation</u>	<u>Material</u>	<u>Thickness</u> (feet)	<u>Depth</u> (feet)
Glacial drift-Continued:			
	Clay, light-olive-gray, silty, with very fine sand, lignite chips, soft, highly-calcar- eous-----	22	41
	Clay, light-olive-gray, silty, smooth, very plastic, highly- calcareous-----	5	46
	Gravel, fine to coarse; sand, coarse-----	2	48
	Clay, light-olive-gray, silty, smooth, very plastic, highly- calcareous-----	8	56
	Gravel, fine to coarse, pre- dominantly limestone; sand, coarse-----	4	60
	Clay, light-olive-gray, silty, smooth, soft, plastic, cal- careous-----	30	90
	Clay, light-olive-gray, sandy, cohesive, micaceous, cal- careous-----	24	114
	Clay, light-olive-gray, silty; till, silty, calcareous-----	15	129
	Gravel, fine to coarse, sub- rounded to rounded, well- sorted-----	18	147
	Gravel, very coarse; pebbles, cobbles and small boulders-----	23	170
Hell Creek Formation:			
	Clay, brownish-black, silty, very micaceous, small particles of lignite, noncalcareous; con- tains orange scoria specks-----	4	174

TABLE 2.--Logs of test holes -- Continued

138-80-8ddd
 Test hole 1863

<u>Formation</u>	<u>Material</u>	<u>Thickness</u> (feet)	<u>Depth</u> (feet)
Glacial drift:			
	Topsoil, black-----	1	1
	Clay, brown, silty to sandy-----	14	15
	Sand, brown, fine to medium, clayey and silty-----	6	21
	Sand, brown, fine to medium; clay, brownish-gray; interbedded, scat- tered lignite fragments-----	11	32
	Sand, brown, fine to very coarse, clayey, rounded, abundant lig- nite-----	4	36
	Sand, brown, medium to very coarse, abundant lignite fragments-----	6	42
	Sand, brown, fine to very coarse, gravelly, poorly-sorted, lignite fragments-----	16	58
	Gravel, fine to medium; sand, brown, medium to very coarse; clay, interbedded, silty-----	5	63
	Gravel, fine to very coarse; sand, very coarse; abundant lignite fragments-----	42	105
	Sand, medium to very coarse; gravel, medium; abundant lignite frag- ments-----	9	114
Hell Creek Formation:			
	Sandstone, light-greenish-gray, fine to very fine-grained, clayey, carbonaceous, abundant glauconite grains-----	12	126
	Sandstone, light-greenish-gray, very fine to fine-grained, very shaley, glauconitic-----	10	136
	Shale, greenish-gray, silty to sandy; siltstone, greenish-gray; glauconitic-----	16	152

TABLE 2.--Logs of test holes -- Continued

138-80-8ddd, Continued
 Test hole 1863

<u>Formation</u>	<u>Material</u>	<u>Thickness</u> (feet)	<u>Depth</u> (feet)
Hell Creek Formation-Continued:			
	Shale, brown, carbonaceous-----	10	162
	Shale, brownish-gray, silty and sandy, glauconite (?) grains-----	6	168

138-80-9bcd
 Paul Wachter irrigation well 1
 Log by Schnell, Inc.

<u>Material</u>	<u>Thickness</u> (feet)	<u>Depth</u> (feet)
Sandy topsoil-----	2	2
Sandy clay loam-----	11	13
Fine sand-----	6	19
Sand with lignite-----	6	25
Sand and wood-----	2	27
Sand-----	2	29
Sand, lignite, and wood-----	9	38
Sandy clay-----	6	44
Lignite and sand-----	9	53
Clay with lignite layers-----	9	62
Rice gravel and lignite-----	7	69
Clay-----	2	71
Gravel-----	15	86
Clay-----	1	87
Lignite and sand-----	4	91
Gravel-----	13	104
Clay-----	1	105

TABLE 2.--Logs of test holes -- Continued

138-80-11ddd
Test hole 1858

<u>Formation</u>	<u>Material</u>	<u>Thickness</u> (feet)	<u>Depth</u> (feet)
Glacial drift:			
	Sand, brown, fine to medium, carbonaceous-----	10	10
	Clay, buff, cohesive-----	11	21
	Clay, brown, silty to sandy-----	10	31
Hell Creek Formation:			
	Shale, light-gray, silty-----	16	47
	Shale, yellowish-brown, and gray, silty-----	5	52
	Shale, medium-gray, silty-----	11	63
	Sandstone, light-gray, very fine to fine-grained, silty, friable, scattered glauconitic grains-----	15	78
	Shale, light to medium-gray, silty; sandstone, light-gray, friable----	6	84

138-80-12bbc
Test hole 1859

<u>Formation</u>	<u>Material</u>	<u>Thickness</u> (feet)	<u>Depth</u> (feet)
Glacial drift:			
	Sand, dark-brown, fine to medium----	5	5
	Clay, light-brown, silty-----	5	10
	Clay, brownish-gray, silty to sandy--	11	21
	Clay, light to medium-gray, silty---	21	42
	Gravel, coarse; sand, very coarse---	1	43
	Clay, medium-gray, silty-----	20	63
	Sand, gray, fine to medium-----	4	67
	Clay, gray, silty, lignite fragments	7	74
	Clay, medium-gray, silty and sandy--	20	94
	Gravel, medium to very coarse, lignite fragments-----	21	115

TABLE 2.--Logs of test holes -- Continued

138-80-13cbb
 C. P. Yegen test hole 1
 Log by Schnell Inc.

<u>Material</u>	<u>Thickness</u> (feet)	<u>Depth</u> (feet)
Sand loam topsoil-----	2	2
Sand-----	25	27
Blue clay-----	31	58
Sandy clay-----	4	62
Medium sand and gravel with lignite lenses-----	6	68
Clay, sandy-----	13	81
Tough clay-----	90	171

138-80-13ccb
 C. P. Yegen test hole 7
 Log by Schnell Inc.

<u>Material</u>	<u>Thickness</u> (feet)	<u>Depth</u> (feet)
Topsoil-----	3	3
Clay-----	14	17
Sand-----	6	23
Clay-----	24	47
Sand-----	20	67
Clay and shale-----	13	80
Shale-----	10	90

TABLE 2.--Logs of test holes -- Continued

138-80-13ccc
Test hole 1857

<u>Formation</u>	<u>Material</u>	<u>Thickness</u> (feet)	<u>Depth</u> (feet)
Glacial drift:			
	Topsoil, brown, sandy and clayey----	5	5
	Sand, brown, fine to medium clayey--	5	10
	Sand, brown, fine to medium, poorly- sorted-----	11	21
	Sand, medium-gray, very fine to fine, silty to clayey; clay, medium-gray, silty and sandy; interbedded-----	21	42
	Sand, medium-gray, very fine to fine, silty to clayey; clay, medium- gray, silty and sandy; interbedded; lignite fragments-----	36	78
	Sand, medium-gray, fine to coarse, gravelly, abundant lignite-----	6	84
Hell Creek Formation:			
	Shale, light-greenish-gray, silty and sandy; sandstone, light-brown, indurated-----	15	99
	Sandstone, bluish-gray, silty and clayey, friable-----	6	105
	Shale, bluish-gray, silty and sandy-	10	115
	Shale, bluish-gray, silty; shale, brownish-gray, silty; interbedded-	6	121
	Sandstone, bluish-gray, very fine to fine-grained, silty and clayey, friable-----	5	126
	Sandstone, bluish-gray, very fine to fine-grained, silty, friable; shale, dark-greenish-gray, silty; interbedded-----	15	141
	Sandstone, dark-greenish-gray, very fine to fine-grained, friable, silty and clayey, abundant glau- conite grains-----	6	147

TABLE 2.--Logs of test holes -- Continued

138-80-13ccc, Continued
Test hole 1857

<u>Formation</u>	<u>Material</u>	<u>Thickness</u> (feet)	<u>Depth</u> (feet)
Fox Hills Sandstone:			
	Shale, dark-brown, carbonaceous-----	19	166
	Sandstone, dark-greenish-gray, very fine to fine-grained, friable, glauconitic(?)-----	2	168
	Shale, brownish-gray, silty, car- bonaceous-----	5	173
	Shale, medium-gray, silty; sand- stone, medium-gray, silty and clayey, interbedded-----	58	231
	Shale, medium-gray, silty, carbon- aceous streaks-----	47	278
	Sandstone, dark-greenish-gray, friable, abundant glauconite, shaley, scattered carbonized wood fragments-----	16	294
	Sandstone, dark-greenish-gray, friable, very abundant glau- conite, carbonized wood frag- ments-----	21	315
	Sandstone, dark-greenish-gray, very fine to fine-grained, friable, abundant glauconite; shale, grayish-green; inter- bedded-----	78	393
	Sandstone, dark-greenish-gray, very fine to fine-grained, friable, silty and clayey, very abundant glauconite-----	6	399
	Sandstone, dark-greenish-gray, very fine to fine-grained, silty and clayey, very abundant glauconite; shale, greenish-gray; black car- bonaceous specks-----	22	421
	Shale, dark-gray, silty; sandstone, greenish-gray; interbedded-----	20	441
Pierre Shale:			
	Shale, grayish-black, silty in part-	52	493

TABLE 2.--Logs of test holes -- Continued

138-80-13cdd
 C. P. Yegen test hole 8
 Log by Schnell Inc.

<u>Material</u>	<u>Thickness</u> (feet)	<u>Depth</u> (feet)
Yellow clay-----	20	20
Gray clay-----	40	60
Fine sand with clay layers-----	23	83
Good gravel with boulders-----	6	89
Gray clay (Fort Union Group)-----	1	90

138-80-15bbd
 Fort Lincoln Nursery irrigation well 2
 Log by Soil Conservation Service

<u>Material</u>	<u>Thickness</u> (feet)	<u>Depth</u> (feet)
Topsoil-----	3	3
Sand and gravel-----	13	16
Very fine sand-----	10	26
Boulder-----	11	27
Clay-----	10	37
Clay-----	10	47
Clay-----	10	57
Clay-----	3	60
Fine and medium sand-----	2	62
Very fine sand-----	5	67
Very fine sand-----	1	68
Boulder-----	1	69
Fine sand-----	8	77
Lignite and gray clay-----	3	87
Lignite-----	6	93
Lignite and fine and medium sand---	4	97
Lignite and medium sand-----	10	107
Lignite and medium sand-----	10	117
Lignite and sand-----	12	129
Boulders (ended hole)-----		129

TABLE 2.--Logs of test holes -- Continued

138-80-15cba
 Fort Lincoln Nursery irrigation well 1
 Log by Soil Conservation Service

<u>Material</u>	<u>Thickness</u> (feet)	<u>Depth</u> (feet)
Topsoil-----	4	4
Gravel-----	20	24
Clay-----	9	33
Fine sand-----	7	40
Blue clay-----	30	70
Fine sand-----	35	105
Fair sand-----	9	114
Fair gravel-----	26	140
Fine sand-----	23	163
Bedrock-----	1	164

138-80-15cdd
 Test hole 1956

<u>Formation</u>	<u>Material</u>	<u>Thickness</u> (feet)	<u>Depth</u> (feet)
Glacial drift:			
	Clay, dark-yellowish-brown, very silty to sandy, oxidized, calcareous-----	7	7
	Gravel, fine to coarse, unsorted, subrounded; sand, coarse to very coarse; lignite fragments, oxidized-----	13	20
	Clay, moderate-yellowish-brown, silty to sandy; gravel, fine, poorly-sorted, subangular, interbedded, calcareous, oxidized---	10	30
	Clay, grayish-olive-green, silty to sandy, cohesive, lignite fragments, calcareous-----	29	59
	Sand, very fine to fine, poorly-sorted, subangular, lignite fragments-----	20	79
	Lignite, detrital, rounded-----	4	83
	Clay, light-olive-gray, silty, cohesive, calcareous-----	10	93

TABLE 2.--Logs of test holes -- Continued

138-80-15cdd, Continued
Test hole 1956

<u>Formation</u>	<u>Material</u>	<u>Thickness</u> (feet)	<u>Depth</u> (feet)
Glacial drift-Continued:			
	Gravel, fine to medium, sub- rounded; sand, medium to very coarse, rounded, lignite frag- ments-----	63	156
Hell Creek Formation:			
	Clay, brownish-gray, very silty to sandy, cohesive, lignite frag- ments-----	12	168

138-80-17aca
Auger hole 22

<u>Formation</u>	<u>Material</u>	<u>Thickness</u> (feet)	<u>Depth</u> (feet)
Glacial drift:			
	Topsoil, pale-yellowish-brown, clay--	4	4
	Clay, moderate-yellowish-brown; sand, fine to medium; silty-----	15	19
	Sand, moderate-yellowish-brown, fine to medium, lignite fragments-----	15	34
	Sand, olive-gray, fine to medium, lignite fragments-----	32	66
	Gravel, fine to coarse; sand, fine to very coarse-----	6	72

TABLE 2.--Logs of test holes -- Continued

138-80-17acb1
 John Petersen irrigation well 1
 Log by Schnell, Inc.

<u>Material</u>	<u>Thickness</u> (feet)	<u>Depth</u> (feet)
Topsoil-----	3	3
Brown sandy soil-----	10	13
Fine sand-----	27	40
Sand and coal (stratified)-----	13	53
Blue clay-----	5	58
Gravel-----	31	89
Clay (Fort Union(?) Group)-----	1	90

138-80-17acb2
 Auger hole 21

<u>Formation</u>	<u>Material</u>	<u>Thickness</u> (feet)	<u>Depth</u> (feet)
Glacial drift:			
	Topsoil, pale-yellowish-brown, clayey to silty-----	4	4
	Clay, moderate-yellowish-brown, silty-----	16	20
	Sand, moderate-yellowish-brown, fine to medium, lignite fragments-----	18	38
	Sand, light-olive-gray, fine to medium, clayey, lignite fragments-----	13	51
	Gravel, medium, sandy, lignite fragments-----	2	53
	Clay, light-olive-gray; sand, fine to medium-----	6	59
	Gravel, fine to very coarse; sand, fine to very coarse-----	8	67

TABLE 2.- Logs of test holes -- Continued

138-80-21ccc
 Test hole 1854

<u>Formation</u>	<u>Material</u>	<u>Thickness</u> (feet)	<u>Depth</u> (feet)
Glacial drift:			
	Topsoil, black-----	1	1
	Clay, buff, silty and sandy-----	20	21
	Clay, brownish-gray, silty-----	6	27
	Sand, light-brown, very fine to fine-----	5	32
	Sand, light-brown, fine to med- ium, clayey, lignite fragments---	17	49
	Gravel, medium to very coarse, lignite fragments-----	12	61
	Gravel, medium, sandy, abundant lignite fragments-----	63	124

Hell Creek Formation:

	Sandstone, medium-gray, very fine to fine-grained, friable; shale, greenish-gray to dark-brown, lignitic-----	18	142
	Sandstone, greenish-gray, fine- grained, friable, clayey and silty, glauconitic (?)-----	5	147

138-80-22aac
 Dan McDonald irrigation well 1
 Log by Burgess Co.

<u>Material</u>	<u>Thickness</u> (feet)	<u>Depth</u> (feet)
Topsoil and clay-----	6	6
Sand-----	2	2
Gravel-----	10	18
Clay and gravel mixed-----	10	28
Clay-----	11	39
Sandy clay-----	35	74
Sand-----	2	76

TABLE 2.--Logs of test holes -- Continued

138-80-22aac, Continued
 Dan McDonald irrigation well 1
 Log by Burgess Co.

<u>Material</u>	<u>Thickness</u> (feet)	<u>Depth</u> (feet)
Sandy clay-----	8	84
Fine sand with lignite and clay layers-----	9	93
Medium sand with lignite-----	5	98
Rice gravel-----	20	118
Coarse gravel with lignite layers--	13	131

138-80-22abd1
 Test hole 1958

<u>Formation</u>	<u>Material</u>	<u>Thickness</u> (feet)	<u>Depth</u> (feet)
Glacial drift:			
	Clay, yellowish-brown, silty-----	4	4
	Sand, very fine to coarse, un- sorted, subangular, lignite fragments, oxidized-----	7	11
	Sand, fine to very coarse, grav- elly, subrounded, lignite fragments, oxidized-----	6	17
	Gravel, fine to medium, sandy, subrounded, oxidized-----	4	21
	Clay, pale-yellowish-brown, silty to sandy, cohesive, lignite fragments, oxidized, calcareous--	19	40
	Clay, light-olive-gray, silty to sandy, cohesive, lignite frag- ments, calcareous-----	34	74
	Clay, light-olive-gray, silty, cohesive, sand, very fine to medium, unsorted, subrounded; lignite fragments-----	11	85

TABLE 2.--Logs of test holes -- Continued

138-80-22abd1, Continued
Test hole 1958

<u>Formation</u>	<u>Material</u>	<u>Thickness</u> (feet)	<u>Depth</u> (feet)
Glacial drift-Continued:			
	Clay, olive-gray, silty to sandy, cohesive; gravel, fine, rounded; interbedded, lignite fragments-----	18	103
	Gravel, very coarse, rounded, lignite fragments-----	49	152

Hell Creek Formation:

	Claystone, medium-bluish-gray, silty-----	5	157
--	---	---	-----

138-80-22abd2
Test hole 1957

<u>Formation</u>	<u>Material</u>	<u>Thickness</u> (feet)	<u>Depth</u> (feet)
Glacial drift:			
	Topsoil, black-----	1	1
	Sand, very fine to coarse, silty to clayey, oxidized-----	3	4
	Gravel, fine to coarse, sandy, unsorted, rounded, oxidized-----	16	20
	Sand, fine to very coarse, well-sorted, angular, oxidized-----	5	25
	Clay, yellowish-brown, sandy, cohesive, lignite fragments-----	7	32
	Clay, light-olive-gray, very silty to sandy, cohesive, lignite fragments-----	30	62

TABLE 2.--Logs of test holes -- Continued

138-80-22abd2, Continued
 Test hole 1957

<u>Formation</u>	<u>Material</u>	<u>Thickness</u> (feet)	<u>Depth</u> (feet)
Glacial drift-Continued:			
	Clay, light-olive-gray, silty to sandy, cohesive; sand, fine; interbedded, lignite fragments-----	28	90
	Sand, fine to medium, well-sorted, angular to subrounded, lignite fragments-----	4	94
	Sand, fine to medium, well sorted; clay, olive-gray, cohesive, interbedded-----	6	100
	Gravel, fine to coarse, sandy, unsorted, angular to rounded, lignite fragments-----	52	152
Hell Creek Formation:			
	Clay, light-olive-gray, silty to sandy, indurated-----	5 1/2	157 1/2

138-80-22bbc
 Dan McDonald test hole
 Log by Schnell, Inc.

<u>Material</u>	<u>Thickness</u> (feet)	<u>Depth</u> (feet)
Topsoil-----	5	5
Sand-----	13	18
Clay-----	3	21
Blue sandy clay-----	14	35
Sand with clay lenses-----	5	40
Blue sand-----	15	55
Gravel-----	9	64
Clay-----	1	65
Lignite-----	2	67
Coarse sand with lignite fragments--	16	83
Lignite-----	1	84
Nice gravel-----	3	87
Coarse gravel-----	11	98
Gravel, and lignite-----	2	100
Sand and gravel with lignite-----	20	120
Lignite-----	2	122
Nice gravel-----	8	130

TABLE 2.--Logs of test holes -- Continued

138-80-23aab
 Dennis Solberg test hole 3
 Log by Schnell, Inc.

<u>Material</u>	<u>Thickness</u> (feet)	<u>Depth</u> (feet)
Topsoil-----	4	4
Sand and coal-----	13	17
Brown clay-----	3	20
Blue clay-----	18	38
Sandy clay-----	13	51
Fine sand-----	33	84
Coal-----	2	86
Medium gravel-----	9	95
Clay-----	5	100

138-80-23aba
 Dennis Solberg test hole 2
 Log by Schnell, Inc.

<u>Material</u>	<u>Thickness</u> (feet)	<u>Depth</u> (feet)
Topsoil-----	3	3
Sand and gravel-----	7	10
Brown clay-----	10	20
Blue clay-----	12	32
Sand-----	14	46
Sandy clay-----	7	53
Fine sand with coal layers-----	32	85
Medium gravel with coal at 90 feet-----	10	95
Clay-----	5	100

TABLE 2.--Logs of test holes -- Continued

138-80-23bdc
 Dennis Solberg irrigation well 1
 Log by Ben Hasz

<u>Material</u>	<u>Thickness</u> (feet)	<u>Depth</u> (feet)
Topsoil-----	1	1
Clay-----	4	5
Sand-----	8	13
Yellow clay-----	12	25
Sand-----	4	29
Blue clay-----	9	38
Blue sand-----	60	98
Sand and gravel-----	4	102
Boulders (gravel)-----	8	110

138-80-23ccc
 Test hole 1855

<u>Formation</u>	<u>Material</u>	<u>Thickness</u> (feet)	<u>Depth</u> (feet)
	Topsoil, black-----	1	1
	Sand, brown, fine to medium, gravelly-----	15	16
	Clay, brown, silty and sandy-----	4	20
	Clay, medium-gray, silty and sandy--	17	37
	Sand, medium-gray, very fine to medium, lignite fragments; clay, medium-gray; interbedded-----	11	48
	Sand, medium-gray, very fine to medium-----	9	57
	Clay, medium-gray; sand, fine to medium, lignite fragments-----	10	67
	Sand, medium-gray, fine to medium; clay, medium-gray; interbedded---	26	93
	Lignite-----	2	95
	Gravel, medium to coarse, clay, gray; interbedded; lignite fragments-----	3	98

TABLE 2.--Logs of test holes -- Continued

138-80-23ccc, Continued
Test hole 1855

<u>Formation</u>	<u>Material</u>	<u>Thickness</u> (feet)	<u>Depth</u> (feet)
Hell Creek Formation:			
	Shale, brownish-black, carbonaceous-----	8	106
	Sandstone, greenish-gray, very fine to fine-grained, silty and clayey, glauconitic (?), friable--	9	115
	Shale, medium to brownish-gray, silty and sandy-----	11	126
	Sandstone, greenish-gray, very fine to fine-grained, glauconitic (?), carbonaceous streaks-----	16	142
	Sandstone, greenish-gray, very fine to fine-grained, glauconitic (?), friable; shale, greenish-gray, silty; interbedded-----	6	148
	Sandstone, greenish-gray, very fine to fine-grained, friable, clayey, silty, glauconitic (?)-----	10	158
	Sandstone, greenish-gray, very fine to fine-grained, friable, silty; shale, brownish-gray, carbonaceous; interbedded-----	4	162
	Shale, brownish-gray, lignite fragments, very carbonaceous-----	17	179
Fox Hills Sandstone:			
	Sandstone, greenish-gray, very fine to fine-grained, friable, shaley and silty-----	62	241
	Shale, greenish-gray, silty and sandy-----	32	273

TABLE 2.--Logs of test holes -- Continued

138-80-24cac1
 C. P. Yegen irrigation well 1
 Log by Schnell Inc.

<u>Material</u>	<u>Thickness</u> (feet)	<u>Depth</u> (feet)
Topsoil-----	3	3
Clay -----	9	12
Sandy clay-----	5	17
Fine sand-----	7	24
Blue clay with sandy clay layers-----	41	65
Sand and lignite-----	1	66
Sandy clay-----	1	67
Sand and lignite-----	2	69
Rice gravel and lignite-----	3	72
Coarse gravel-----	8	80
Sandy clay-----	2	82
Lignite-----	1	83
Sandy clay-----	1	84
Tough clay-----	1	85

138-80-24cac2
 53' SE of irrigation well 1
 C. P. Yegen Observation Well
 Log by Schnell, Inc.

<u>Material</u>	<u>Thickness</u> (feet)	<u>Depth</u> (feet)
Topsoil-----	2	2
Sandy clay-----	5	7
Fine brown sand-----	7	14
Fine gray sand-----	5	19
Gray clay-----	24	44
Fine sand-----	3	47
Clay with streaks of fine sand at 56 feet-----	15	62
Fine sand-----	7	69
Medium sand and gravel with boulders (drilled tight)-----	7	76
Tight sandy clay-----	14	90

(Water level 5.91 feet below land
 surface)

TABLE 2.--Logs of test holes -- Continued

138-80-24cac3
 C. P. Yegen Observation well
 (160 feet SE of irrigation well 1)
 Log by Schnell Inc.

<u>Material</u>	<u>Thickness</u> (feet)	<u>Depth</u> (feet)
Topsoil-----	2	2
Yellow sandy clay-----	9	11
Gray clay-----	13	24
Fine sand-----	2	26
Gray clay-----	45	71
Medium gravel with boulders-----	3	74
Sandy clay-----	16	90

(Water level 7.83 feet below land
 surface)

138-80-24cbd
 C. P. Yegen test hole 2
 Log by Schnell Inc.

<u>Material</u>	<u>Thickness</u> (feet)	<u>Depth</u> (feet)
Topsoil-----	3	3
Yellow clay-----	11	14
Sand-----	4	18
Blue clay with sand lenses-----	21	39
Sand with clay layers-----	15	54
Clay-----	18	72
Sand and lignite-----	2	74
Gravel-----	4	78
Coarse sand with lignite-----	13	91

TABLE 2.--Logs of test holes -- Continued

138-80-24cca
 C. P. Yegen test hole 3
 Log by Schnell Inc.

<u>Material</u>	<u>Thickness</u> (feet)	<u>Depth</u> (feet)
Topsoil-----	3	3
Yellow clay-----	6	9
Sand-----	10	19
Clay-----	11	30
Sand-----	18	48
Clay-----	19	67
Sand, medium to coarse with lignite-	11	78
Rock layers-----	3	81
Shale-----	9	90

138-80-24daa
 Auger hole 2

<u>Formation</u>	<u>Material</u>	<u>Thickness</u> (feet)	<u>Depth</u> (feet)
Glacial drift:			
	Sand, moderate-yellowish-brown, very fine to medium, lignite fragments-----	7	7
	Sand, dusky-brown, very fine to medium, gravelly-----	3	10
	Sand, grayish-brown, fine to coarse, lignite fragments-----	11	21
	Clay, light-olive-gray, plastic, smooth, cohesive-----	6	27

TABLE 2.--Logs of test holes -- Continued

138-80-24dac
 C. P. Yegen test hole 5
 Log by Schnell Inc.

<u>Material</u>	<u>Thickness</u> (feet)	<u>Depth</u> (feet)
Sandy loam topsoil-----	3	3
Yellow sandy clay-----	6	9
Sand-----	25	34
Blue clay with traces of sand layers-----	46	80
Fine sand with lignite-----	3	83
Sandy blue clay-----	4	87
Fine sand with lignite (not good)---	12	99
Clay-----	6	105
Sand (fair)-----	3	108
Sandy clay-----	8	116
Medium sand-----	4	120
Sand with clay layers-----	4	124
Gravel-----	11	135
Green tough clay with gravel mixed (not good)-----	5	140
Shale-----	10	150

138-80-24ddc
 C. P. Yegen test hole 6
 Log by Schnell Inc.

<u>Material</u>	<u>Thickness</u> (feet)	<u>Depth</u> (feet)
Topsoil-----	2	2
Sand-----	27	29
Clay-----	13	42
Sandy clay-----	22	64
Sand-----	4	68
Sandy clay-----	30	98
Fine sand (fair)-----	26	124
Sandy clay-----	4	128
Fine sand with traces of lignite---	15	143
Fine sand with cemented sand layers (tight)-----	67	210
Shale-----	1	211

TABLE 2.--Logs of test holes -- Continued

138-80-25ddd
 (566 feet SE of irrigation well 3)
 C. P. Yegen observation well
 Log by Schnell, Inc.

<u>Material</u>	<u>Thickness</u> (feet)	<u>Depth</u> (feet)
Topsoil-----	1	1
Brown sand-----	26	27
Sandy clay-----	16	43
Gravel-----	1	44
Sandy clay-----	8	52
Fine blue sand (tight)-----	11	63
Dark clay-----	1	64
Fine sand with lignite-----	16	80
Sticky clay-----	3	83
Fine to coarse sand-----	2	85
Sticky clay-----	41	126
Fine blue sand (tight)-----	8	134
Hard coal-----	1	135
Fine sand with clay streaks-----	2	137
Clay-----	3	140
Fine sand-----	3	143
Clay-----	10	153
Very fine sand (tight)-----	30	183
Coal-----	1	184
Clay-----	10	194
Rock layer and clay-----	1	195

(Water level 40.00 feet below land surface)

138-80-25bab
 C. P. Yegen irrigation well 2
 Log by Schnell Inc.

<u>Material</u>	<u>Thickness</u> (feet)	<u>Depth</u> (feet)
Topsoil-----	4	4
Sand-----	5	9
Clay-----	8	17
Sand-----	11	28
Clay-----	33	61
Fine sand, gray-----	19	80
Coarse sand and fine gravel-----	13	93
Coarse gravel-----	5	98
Clay-----	2	100

TABLE 2.--Logs of test holes -- Continued

138-80-25bba
 C. P. Yegen test hole 4
 Log by Schnell Inc.

<u>Material</u>	<u>Thickness</u> (feet)	<u>Depth</u> (feet)
Topsoil-----	2	2
Yellow clay-----	6	8
Sand-----	10	18
Clay-----	50	68
Sand and gravel-----	7	75
Coarse sand with boulders-----	6	81

138-80-25cda
 C. P. Yegen test hole 10
 Log by Schnell Inc.

<u>Material</u>	<u>Thickness</u> (feet)	<u>Depth</u> (feet)
Topsoil-----	2	2
Sandy clay-----	8	10
Dark Clay-----	7	17
Green-blue clay-----	15	32
Black clay-----	8	40
Brown clay-----	6	46
Sand blue clay-----	12	58
Lignite-----	1	59
Green sandstone-----	1	60

138-80-25dac
 C. P. Yegen irrigation well 3
 Log by Schnell Inc.

<u>Material</u>	<u>Thickness</u> (feet)	<u>Depth</u> (feet)
Topsoil-----	2	2
Brown sand-----	14	16
Blue sand and coal-----	9	25
Coal-----	7	32
Sand and coal-----	14	46
Sticky clay-----	34	80

TABLE 2.--Logs of test holes -- Continued

138-80-25dac, Continued
 C. P. Yegen irrigation well 3
 Log by Schnell Inc.

<u>Material</u>	<u>Thickness</u> (feet)	<u>Depth</u> (feet)
Sandy clay with gravel and coal.....	12	92
Sticky clay.....	10	102
Blue sand.....	2	104
Coal.....	1	105
Blue sand.....	1	106
Coal.....	1	107
Sand and coal.....	9	116
Clay.....	1	117
Silty clay.....	6	123
Sand and coal.....	3	126
Clay.....	16	142
Sand and coal.....	13	155

138-80-25abd
 C. P. Yegen test hole 3
 Log by Schnell Inc.

<u>Material</u>	<u>Thickness</u> (feet)	<u>Depth</u> (feet)
Topsoil.....	2	2
Sandy clay.....	28	30
Clay with sand layers.....	45	75
Clay (Fort Union Group).....	5	80

138-80-25dda1
 C. P. Yegen test hole 11
 Log by Schnell Inc.

<u>Material</u>	<u>Thickness</u> (feet)	<u>Depth</u> (feet)
Topsoil.....	2	2
Dry sand.....	8	10
Yellow clay.....	2	12
Sand.....	4	16
Clay.....	1	17
Sand.....	21	38

TABLE 2.--Logs of test holes -- Continued

138-80-25ddal, Continued
 C. P. Yegen test hole 11
 Log by Schnell Inc.

<u>Material</u> -Continued:	<u>Thickness</u> (feet)	<u>Depth</u> (feet)
Medium sand with lignite-----	47	85
Sticky gray clay-----	45	130
Sand and gravel cemented-----	24	155
Sand with lignite layers-----	44	199
Rock-----	2	201

138-80-25dda2
 (150 feet SE of irrigation well 3)
 C. P. Yegen observation well
 Log by Schnell, Inc.

<u>Material</u>	<u>Thickness</u> (feet)	<u>Depth</u> (feet)
Topsoil-----	1	1
Brown sand-----	23	24
Gravel and coal streaks-----	2	26
Fine to medium sand-----	29	55
Coal-----	2	57
Sandy clay-----	5	62
Sticky gray clay (sand from 73-81 feet)-----	41	103
Coal-----	2	105
Fine sand with coal-----	11	116
Clay-----	1	117
Fine sand with coal (tight)-----	8	125
Clay-----	1	126
Fine sand with coal (tight)-----	2	128
Clay-----	3	131
Fine sand (drills tight)-----	3	134
Sticky clay-----	11	145
Fine sand with coal-----	14	159
Rock-----	1	160
Gray clay-----	4	164
Rock-----	1	165
Solid clay-----	15	180

(Water level 23.69 feet below land
 surface)

TABLE 2.--Logs of test holes -- Continued

138-80-25dda3

C. P. Yegen test hole 11a

<u>Formation</u>	<u>Material</u>	<u>Thickness</u> (feet)	<u>Depth</u> (feet)
Glacial drift:			
	Topsoil, yellowish-brown-----	2	2
	Sand, very fine to medium, oxidized, silty to clayey-----	40	42
	Gravel, fine to medium, mostly limestone and shale-----	2	44
	Clay, light-olive-gray-----	1	45
	Sand, very fine to medium, silty, a trace of lignite at 56 feet-----	9	64
	Sand, very fine to medium, sub- rounded to angular, silty-----	25	89
	Clay, light-olive-gray, silty-----	4	93
	Sand, fine to medium-----	5	98
	Clay, dark-olive-gray, plastic-----	8	106
	Silt, olive-gray, clayey, cal- careous-----	21	127
	Peat and lignite-----	1	128
	Silt, clayey; sand, fine to medium--	3	131
	Sand, medium to very coarse-----	5	136
	Gravel, fine to coarse, angular with streaks of clay-----	3	139
	Silt, sandy-----	7	146
	Clay, light-olive-gray, silty-----	10	156
	Silt, light-olive-gray; sand, fine, angular-----	1	157
	Clay, light-olive-gray, silty-----	2	159
	Sand, very fine to medium, angular, silty-----	8	167
	Clay, light-olive-gray, plastic-----	3	170
	Sand, very fine to medium, angular, silty; lignite fragments from 173 to 175 feet; clay, olive- gray, plastic-----	16	186

TABLE 2.--Logs of test holes -- Continued

138-80-25ddb
 C. P. Yegen test hole 12
 Log by Schnell, Inc.

<u>Material</u>	<u>Thickness</u> (feet)	<u>Depth</u> (feet)
Sandy clay-----	9	9
Sand-----	29	38
Lignite-----	1	39
Sand and gravel-----	27	66
Clay-----	49	115
Medium sand-----	25	140
Coarse sand (still in sand but lost circulation)-----	20	160

138-80-27cdc
 Test hole 1929

<u>Formation</u>	<u>Material</u>	<u>Thickness</u> (feet)	<u>Depth</u> (feet)
Glacial drift:			
	Clay, dark-yellowish-brown, silty, cohesive, lignite fragments, oxidized, calcareous-----	12	12
	Sand, very fine to fine, silty, poorly sorted, angular to rounded, lignite fragments, oxidized-----	5	17
	Sand, very fine to fine, well- sorted, angular to rounded, lignite fragments-----	9	26
	Sand, very fine to coarse, poorly-sorted, subangular to rounded, lignite fragments-----	15	41
Hell Creek Formation:			
	Clay, greenish-gray to yellowish- orange, silty to sandy, indur- ated, snail shells, lignite fragments-----	11 1/2	52 1/2

TABLE 2.--Logs of test holes -- Continued

138-80-27dda
Test hole 1856

<u>Formation</u>	<u>Material</u>	<u>Thickness</u> (feet)	<u>Depth</u> (feet)
Glacial drift:			
	Topsoil, dark-brown, sandy-----	5	5
	Clay, buff, silty to sandy-----	16	21
	Clay, medium-gray, silty; sand, very fine to fine; interbedded---	22	43
Hell Creek Formation:			
	Shale, medium-gray, silty, carbonaceous-----	4	47
	Shale, light-greenish-gray, silty and sandy, glauconitic (?)-----	5	52
	Sandstone, greenish-gray, very fine to fine-grained, friable, silty and clayey-----	11	63
	Shale, brownish-black, very carbonaceous-----	5	68
	Shale, medium-gray, silty-----	5	73
	Shale, light-greenish-gray, silty to sandy, glauconitic (?)-----	5	78
	Shale, medium-gray, silty; sandstone, greenish-gray, friable; interbedded-----	11	89
	Sandstone, light-greenish-gray, very fine to fine-grained, silty and clayey, friable, glauconitic-----	16	105
	Shale, brownish-gray, carbonaceous, lignite seams-----	16	121
	Sandstone, light-greenish-gray, very fine to fine-grained, silty and clayey-----	5	126
	Shale, medium-gray, silty; sandstone, dark-greenish-gray, friable, very glauconitic-----	5	131
	Sandstone, dark-greenish-gray, friable, very glauconitic-----	5	136
	Shale, brownish-gray, carbonaceous; lignite seams; interbedded-----	5	141

TABLE 2.--Logs of test holes -- Continued

138-80-27dda, Continued
Test hole 1856

<u>Formation</u>	<u>Material</u>	<u>Thickness</u> (feet)	<u>Depth</u> (feet)
Fox Hills Sandstone:			
	Sandstone, light-greenish-gray, very fine to fine, silty and clayey, scattered glauconite grains-----	6	147

138-80-29bab
Test hole 1013

<u>Formation</u>	<u>Material</u>	<u>Thickness</u> (feet)	<u>Depth</u> (feet)
Glacial drift:			
	Sand, fine, clayey-----	7	7
	Sand, fine to medium, lignite and wood fragments-----	25	32
	Sand, fine to medium; gravel, fine; lignite and wood fragments-	20	52
	Clay, light-gray-----	5	57
	Sand, fine to medium, silty-----	4	61
	Gravel, medium to coarse-----	9	70

138-80-29bad
State Prison Farm irrigation well 1
Log by Schnell Inc.

<u>Material</u>	<u>Thickness</u> (feet)	<u>Depth</u> (feet)
Topsoil-----	4	4
Sand-----	4	8
Brown clay-----	11	19
Gray fine sand-----	13	32
Gray clay-----	2	34
Sand, medium, coal-----	18	52
Sand and clay layers (stratified)--	11	63

TABLE 2.--Logs of test holes -- Continued

138-80-29bad, Continued
 State Prison Farm irrigation well 1
 Log by Schnell Inc.

<u>Material</u>	<u>Thickness</u> (feet)	<u>Depth</u> (feet)
Fine gravel-----	7	70
Medium and coarse gravel-----	23	93
Clay, sandy-----	3	96
Medium sand-----	10	106
Clay-----	4	110

138-80-29bbb1
 Test hole 1012

<u>Formation</u>	<u>Material</u>	<u>Thickness</u> (feet)	<u>Depth</u> (feet)
Glacial drift:			
	Clay, brown, sandy-----	2	2
	Clay, brown, smooth-----	6	8
	Sand, fine to coarse, lignite fragments-----	82	90
	Gravel, fine to coarse, rounded----	30	120
	Gravel, coarse, sandy; clay, gray-----	5	125
Hell Creek Formation:			
	Clay, light-gray; sandy, fine to coarse-----	5	130

TABLE 2.--Logs of test holes -- Continued

138-80-29bbb2
Test hole 1853

<u>Formation</u>	<u>Material</u>	<u>Thickness</u> (feet)	<u>Depth</u> (feet)
Glacial drift:			
	Topsoil, brown, silty-----	5	5
	Clay, yellowish-brown, silty; sand, light-gray, very fine to fine-----	5	10
	Sand, medium-gray, very fine to fine, clayey-----	11	21
	Sand, medium-gray, fine to medium, well-rounded, lignite fragments---	10	31
	Sand, medium-gray, medium to coarse, well-rounded, poorly-sorted, lig- nite fragments-----	23	54
	Gravel, medium to coarse, clayey to silty, abundant lignite frag- ments-----	9	63
	Gravel, medium to coarse; sand, gray, medium to coarse; inter- bedded, abundant lignite frag- ments-----	10	73
	Sand, medium-gray, fine to medium, abundant lignite fragments-----	19	92
	Gravel, coarse to very coarse, abundant lignite fragments-----	19	111
Hell Creek Formation:			
	Shale, greenish-gray to brownish- black, lignitic, sandstone, greenish-gray, clayey, glaucon- itic (?), friable-----	25	136
	Shale, brown and brownish-gray, lignitic, very carbonaceous-----	6	142
	Sandstone, greenish-gray, very fine to fine-grained, friable, clayey, glauconitic (?)------	5	147

TABLE 2.--Logs of test holes -- Continued

139-75-3ddd
 Test hole 1977

<u>Formation</u>	<u>Material</u>	<u>Thickness</u> (feet)	<u>Depth</u> (feet)
Glacial drift:			
	Topsoil-----	1	1
	Gravel, fine to medium, subangular to rounded, oxidized-----	3	4
	Clay, moderate-yellowish-brown----	16	20
	Till, olive-gray, silty to sandy, lignite fragments, calcareous----	54	74
Hell Creek Formation:			
	Sandstone, grayish-green, mica and lignite fragments, glau- conitic -----	11	85
	Sandstone, grayish-blue-green, friable, lignite flakes, glauconitic -----	15	100
	Clay, dusky-yellowish-brown, silty, carbonaceous-----	13	113
	Sandstone, grayish-blue-green, med- ium-grained, glauconitic-----	29	142
Fox Hills Sandstone:			
	Sandstone, medium-bluish-gray, clayey, lignite flakes, glau- conitic; shale, olive-gray-----	16	158
	Sandstone, light-gray, very fine grained, well-indurated, cal- careous-----	3	161
	Clay, olive-gray, silty, well- indurated; sandstone, medium- bluish-gray, glauconitic-----	2	163
	Shale, olive-gray, silty, in- durated-----	7	170
	Sandstone, olive to greenish- gray, clayey, glauconitic-----	17	187
	Sandstone, light-gray, very fine- grained-----	1	188
	Sandstone, dark-greenish-gray, lignite fragments, glauconitic---	32	220

TABLE 2.--Logs of test holes -- Continued

139-75-3ddd, Continued
Test hole 1977

<u>Formation</u>	<u>Material</u>	<u>Thickness</u> (feet)	<u>Depth</u> (feet)
	Sandstone, dark-greenish-gray, very fine to fine-grained, lignite and mica flakes, glaucanitic-----	32	252
	Sandstone, moderate-bluish-green, very fine to fine-grained, abun- dant glauconite; shale, light- olive-gray, sandy, abundant lignite-----	32	284

139-75-19caa
Test hole 2049D

<u>Formation</u>	<u>Material</u>	<u>Thickness</u> (feet)	<u>Depth</u> (feet)
Glacial drift:			
	Topsoil-----	1	1
	Clay, gray, silty, highly-cal- careous-----	4	5
	Gravel, medium to very coarse; sand, coarse; subrounded, un- sorted, oxidized-----	10	15
	Till, dark-greenish-gray, a- bundant shale, calcareous-----	26	41
	Gravel, granular, sand, medium to coarse; subangular to subrounded-----	5	46
Hell Creek Formation:			
	Shale, dusky-brown, lignitic, silty, oxidized-----	3	49
	Shale, dark-greenish-gray, very silty, some lignite-----	3 1/2	52 1/2

TABLE 2.--Logs of test holes -- Continued

139-75-22ccb
Test hole 2020

<u>Formation</u>	<u>Material</u>	<u>Thickness</u> (feet)	<u>Depth</u> (feet)
Glacial drift:			
	Till, moderate-yellowish-brown, silty, lignite fragments, oxidized, highly-calcareous-----	10	10
	Till, dark-yellowish-orange, silty, lignite fragments, oxidized, highly-calcareous-----	22	32
	Till, dark-greenish-gray, abundant shale, lignite and boulders-----	25	57
Hell Creek Formation:			
	Sandstone, medium-bluish-gray, very fine to fine-grained, silty, indurated, black and green grains, some organic material-----	3	60

139-76-20abb
Test hole 2017

<u>Formation</u>	<u>Material</u>	<u>Thickness</u> (feet)	<u>Depth</u> (feet)
Glacial drift:			
	Topsoil, black-----	1 1/2	1 1/2
	Sand, very fine to coarse, silty to clayey, unsorted, calcareous, oxidized-----	10 1/2	12
	Till, moderate-yellowish-brown, highly-calcareous, oxidized-----	13	25
	Till, moderate-yellowish-brown, rusty streaks, highly calcareous, oxidized-----	17	42
Cannonball Formation:			
	Silt, olive-black, clayey to sandy, indurated, mica flakes, oxidized-----	8	50

TABLE 2.--Logs of test holes -- Continued

139-76-26dda
Test hole 2034

<u>Formation</u>	<u>Material</u>	<u>Thickness</u> (feet)	<u>Depth</u> (feet)
Glacial drift:			
	Till, yellowish-brown, silty-----	1	1
	Gravel, medium to coarse, sub- angular to subrounded, poorly- sorted-----	4	5
Hell Creek Formation:			
	Sand, light-olive-gray, fine, silty to clayey, plastic, partially- oxidized-----	9	14
	Sand, olive-gray, fine, silty to clayey, plastic-----	2	16
	Shale, olive-gray, sandy, indurated--	4	20
	Shale, brownish-gray, silty to sandy-----	9	29
	Shale, bluish-olive-gray, silty to sandy, smooth, indurated-----	13	42

139-77-1bbb
Test hole 2055

<u>Formation</u>	<u>Material</u>	<u>Thickness</u> (feet)	<u>Depth</u> (feet)
Glacial drift:			
	Topsoil, sandy-----	1	1
	Sand, gray to black, fine, clayey and silty, calcareous-----	4	5
	Sand, clayey, some gravel-----	1	6
	Till, moderate-olive-brown, very sandy, leached, oxidized-----	11	17
	Till, olive-gray, silty, calcareous--	22	39
	Till, olive-gray, very sandy, calcareous, much reworked bed- rock-----	11	50
	Gravel, fine to medium, oxidized-----	1	51

TABLE 2.--Logs of test holes -- Continued

139-77-1bbb, Continued
 Test hole 2055

<u>Formation</u>	<u>Material</u>	<u>Thickness</u> (feet)	<u>Depth</u> (feet)
Cannonball Formation:			
	Sand, moderate-olive-brown, fine, loosely-consolidated, oxidized---	12	63

139-77-6aaa
 Test hole 1934

<u>Formation</u>	<u>Material</u>	<u>Thickness</u> (feet)	<u>Depth</u> (feet)
Glacial drift;			
	Topsoil, black-----	2	2
	Clay, dark-brown, sand, carbon- aceous-----	4	6
	Sand, gray, fine to very coarse, gravelly, abundant shale-----	11	17
	Clay, greenish-gray, silty-----	3	20
	Gravel, fine to medium, sandy, lig- nite fragments-----	2	22
	Clay, olive-gray, silty and sandy--	10	32
	Clay, olive-gray, very silty; sand, fine to very coarse; interbedded-	21	53
	Clay, medium to olive-gray, silty and sandy-----	6	59
	Sand, very coarse, gravelly-----	9	68

Hell Creek Formation:

	Shale, grayish-brown, silty and sandy; sandstone, medium-dark- gray, abundant green grains-----	15	83
	Shale, medium-gray, silty and sandy-----	11	94

TABLE 2.--Logs of test holes -- Continued

139-77-8cbc
Test hole 1953

<u>Formation</u>	<u>Material</u>	<u>Thickness</u> (feet)	<u>Depth</u> (feet)
Glacial drift:			
	Topsoil-----	1	1
	Gravel, fine, sandy, unsorted, sub- rounded, oxidized-----	2	3
	Clay, pale yellowish-brown, silty, cohesive, lignite fragments, cal- careous, oxidized-----	16	19
	Sand, fine to coarse, poorly- sorted, angular to rounded, lig- nite fragments, oxidized-----	21	40
	Sand, fine to coarse, poorly-sorted, angular to rounded, lignite frag- ments-----	6	46
	Clay, light-olive-gray, silty, co- hesive, highly calcareous-----	6	52
	Clay, dark-greenish-gray, silty to sandy, slightly cohesive, lignite fragments, calcareous-----	16	68
	Clay, light-olive-gray, silty, co- hesive, highly-calcareous-----	36	104
Hell Creek Formation:			
	Clay, greenish-gray, silty to sandy, cohesive, black specks-----	11	115

139-77-15ccc
Test hole 2016

<u>Formation</u>	<u>Material</u>	<u>Thickness</u> (feet)	<u>Depth</u> (feet)
Glacial drift:			
	Clay, moderate-yellowish-brown, silty, calcareous, oxidized-----	12	12
	Clay, moderate-yellowish-brown, silty, cohesive, calcareous, oxidized-----	8	20

TABLE 2.--Logs of test holes -- Continued

139-77-15ccc, Continued
Test hole 2016

<u>Formation</u>	<u>Material</u>	<u>Thickness</u> (feet)	<u>Depth</u> (feet)
Glacial drift-Continued			
	Gravel, fine to medium, sandy, unsorted, subrounded, abundant carbonates-----	2 1/2	22 1/2
	Till, dark-greenish-gray, very sandy, lignite fragments, calcareous-----	8	30 1/2
Cannonball Formation:			
	Sand, greenish-gray, silty to clayey, abundant black and green grains, some mica and lignite flecks-----	14 1/2	45

139-77-20ccc
Test hole 2036

<u>Formation</u>	<u>Material</u>	<u>Thickness</u> (feet)	<u>Depth</u> (feet)
Glacial drift:			
	Topsoil, black-----	7	7
	Silt, moderate-yellowish-brown, cohesive, calcareous, oxidized---	6	13
	Silt, dark-greenish-gray, lignite fragments, calcareous-----	27	40
	Silt, dark-greenish-gray, clayey, tiny lignite flecks, calcareous--	15	65
	Gravel, fine to coarse, sandy, unsorted, subrounded, predominately carbonates-----	3	68
	Silt, light-olive-gray, cohesive, calcareous-----	39	107

TABLE 2.--Logs of test holes -- Continued

139-77-20ccc, Continued
Test hole 2036

<u>Formation</u>	<u>Material</u>	<u>Thickness</u> (feet)	<u>Depth</u> (feet)
Glacial drift-Continued:			
	Sand, very fine to fine, silty to clayey, unsorted, abundant lignite fragments-----	45	152
	Sand, medium, silty to clayey, unsorted abundant, carbonates and lignite-----	56	208
	Boulder, limestone-----	1 1/2	209 1/2
Fox Hills Sandstone:			
	Silt, dark-greenish-gray, clayey, indurated, mica flakes-----	15 1/2	225

139-77-32aaa
Test hole 1866

<u>Formation</u>	<u>Material</u>	<u>Thickness</u> (feet)	<u>Depth</u> (feet)
Glacial drift:			
	Topsoil, black-----	1	1
	Clay, light-brown to light-gray, silty-----	25	26
	Clay, medium-gray, silty-----	16	42
	Clay, brownish-gray, cohesive-----	48	90
	Gravel, medium; sand, very coarse--	1	91
	Clay, medium-gray, silty in part---	35	126
	Clay, medium-gray; sand, fine to medium; silty-----	63	189
	Gravel, medium to coarse; sand, coarse; abundant lignite-----	11	200
Fox Hills Sandstone:			
	Shale, medium-gray, silty, car- bonaceous-----	31	231

TABLE 2.--Logs of test holes -- Continued

139-77-32aaa, Continued
Test hole 1866

<u>Formation</u>	<u>Material</u>	<u>Thickness</u> (feet)	<u>Depth</u> (feet)
Fox Hills Sandstone-Continued:			
	Shale, greenish-gray, silty, sandstone, fine to very fine-grained, friable, abundant green grains----	21	252

139-77-34bbb
Test hole 2035

<u>Formation</u>	<u>Material</u>	<u>Thickness</u> (feet)	<u>Depth</u> (feet)
Glacial drift:			
	Clay, grayish-orange, silty, highly-calcareous, oxidized-----	5	5
	Clay, moderate to dark-yellowish-brown, silty, highly-calcareous, oxidized-----	22	27
Hell Creek Formation:			
	Sand, dusky-yellow, very fine to fine, clayey, cohesive, oxidized--	8	35
	Sand, dark-greenish-gray, very fine to fine, clayey, lignite fragments-----	6	41
	Clay, dark-yellowish-brown, silty, indurated, abundant lignite fragments-----	4	45

TABLE 2.--Logs of test holes -- Continued

139-78-8aaa
Test hole 1950

<u>Formation</u>	<u>Material</u>	<u>Thickness</u> (feet)	<u>Depth</u> (feet)
Glacial drift:			
	Clay, light-olive-gray, silty and sandy, calcareous-----	6	6
	Clay, medium-dark-gray, very sandy, silty, calcareous-----	1	7
	Gravel, fine; sand, coarse to very coarse-----	2	9
	Clay, medium-dark-gray, very sandy, silty, calcareous-----	8	17
	Gravel, fine to medium-----	3	20
	Till, olive to greenish-gray, sandy, lignite and shale particles-----	26	46
	Clay, olive-gray, very sandy, silty, lignite flakes-----	30	76
	Clay, brownish-gray to olive-black, sandy and silty, carbonaceous, calcareous-----	8	84
	Clay, olive-gray, sandy, silty, calcareous-----	8	92
	Shale, brownish-gray to greenish-gray, silty-----	13	105

139-78-11aaa
Test hole 1951

<u>Formation</u>	<u>Material</u>	<u>Thickness</u> (feet)	<u>Depth</u> (feet)
Glacial drift:			
	Sand, light-olive-gray, clayey, silty, calcareous-----	10	10
	Gravel, fine to medium; sand, medium to very coarse; clay, olive-gray, silty-----	5	15
	Clay, olive-gray, silty, lignite fragments-----	20	35

TABLE 2.--Logs of test holes -- Continued

139-78-11aaa, Continued
Test hole 1951

<u>Formation</u>	<u>Material</u>	<u>Thickness</u> (feet)	<u>Depth</u> (feet)
Hell Creek Formation:			
	Sandstone, greenish-gray, medium to very fine grained, silty and clayey, friable, abundant dark grains-----	7	42
	Shale, brownish-gray, silty, carbonaceous, lignite fragments-----	11	53
	Sandstone, greenish-gray, very fine to fine-grained, friable, silty and clayey, mica flakes, scattered dark minerals, glauconitic-	10	63

139-78-11abb
Test hole 1932

<u>Formation</u>	<u>Material</u>	<u>Thickness</u> (feet)	<u>Depth</u> (feet)
Glacial drift:			
	Topsoil, black-----	1	1
	Clay, dark-yellowish-orange, silty to sandy, calcareous, oxidized----	6	7
	Clay, moderate-yellowish-brown, silty, cohesive, calcareous, oxidized-----	9	16
	Clay, dark-yellowish-orange, very silty, cohesive, calcareous, oxidized-----	18	34
Hell Creek Formation:			
	Sand, greenish-gray to brownish-gray, silty to clayey, lignite fragments, abundant green grains--	29	63

TABLE 2.--Logs of test holes -- Continued

139-78-16ccc
Test hole 1865

<u>Formation</u>	<u>Material</u>	<u>Thickness</u> (feet)	<u>Depth</u> (feet)
Glacial drift:			
	Topsoil, black-----	2	2
	Clay, brown to buff, silty and sandy-----	13	15
	Gravel, medium; sand, medium to very coarse-----	2	17
	Clay, light to medium-gray, silty and sandy-----	5	22
	Gravel, fine; sand, very coarse-----	4	26
	Clay, brownish-gray, silty-----	10	36
	Clay, medium-gray, silty-----	6	42
	Sand, gray, very fine to medium, silty, poorly-sorted, well- rounded, abundant lignite frag- ments-----	21	63
	Sand, gray, very fine to medium, silty, rounded; clay, medium- gray, silty, interbedded with sand-----	31	94
	Clay, medium-gray, silty to sandy----	11	105
	Sand, gray, very fine to medium, silty; clay, medium-gray; abun- dant lignite; interbedded sand and clay-----	43	148
	Gravel, medium to coarse; sand, medium to very coarse; a-- bundant lignite from 148-153 feet-----	11	159
Hell Creek Formation:			
	Shale, light-bluish-gray, silty, sandy in part, abundant glau- conite grains-----	14	173
	Sandstone, greenish-gray, fine to very fine-grained, friable, abundant glauconite grains, specks of black and brown, carbonaceous-----	10	183

TABLE 2.--Logs of test holes -- Continued

139-78-16ccc, Continued
Test hole 1865

<u>Formation</u>	<u>Material</u>	<u>Thickness</u> (feet)	<u>Depth</u> (feet)
Fox Hills (?) Sandstone:			
	Shale, light-greenish-gray, silty; sandstone, greenish-gray, fine to very fine grained, silty, abundant glauconite grains; interbedded.....	27	210

139-78-19ddd
Test hole 2011

<u>Formation</u>	<u>Material</u>	<u>Thickness</u> (feet)	<u>Depth</u> (feet)
Glacial drift:			
	Topsoil, black.....	2	2
	Silt, dark-yellowish-orange, slightly-cohesive, abundant lig- nite fragments, highly-calcareous, oxidized.....	10	12
	Silt, dark-yellowish-brown, co- hesive, lignite fragments, highly- calcareous, oxidized.....	24	36
	Clay, dark-greenish-gray, silty, cohesive, lignite fragments, calcareous.....	4	40
	Gravel, fine, sandy, subrounded to well-rounded, unsorted, abundant carbonates.....	4	44
	Sand, very fine to medium, silty, unsorted, angular to subangular, abundant lignite fragments.....	10	54
	Clay, greenish-gray, silty, co- hesive, calcareous.....	6	60
	Silt, greenish-gray, sandy, un- sorted, cohesive, lignite and mica flakes, calcareous.....	30	90

TABLE 2.--Logs of test holes -- Continued

139-78-19ddd, Continued
Test hole 2011

<u>Formation</u>	<u>Material</u>	<u>Thickness</u> (feet)	<u>Depth</u> (feet)
Hell Creek Formation:			
	Sand, dark-greenish-gray, very fine to fine, cohesive, abundant lignite, changing to dark-yellowish-green-----	45	135

139-78-22bb
T. C. Casey test hole 10
Log by Schnell Inc.

<u>Material</u>	<u>Thickness</u> (feet)	<u>Depth</u> (feet)
Topsoil-----	2	2
Sandy clay loam-----	16	18
Sand, gravel, and clay-----	5	23
Sand and gravel-----	9	32
Gravel, with clay, blue-----	10	42
Blue clay-----	55	97
White rock chips and gravel-----	3	100
Fine sand with sandy clay layers----	40	140
Soft sand rock with clay layers----	12	152
Sand rock-----	15	167
Gravel-----	28	195

TABLE 2.--Logs of test holes -- Continued

139-78-22bd
 T. C. Casey test hole 13
 Log by Schnell Inc.

<u>Material</u>	<u>Thickness</u> (feet)	<u>Depth</u> (feet)
Topsoil-----	4	4
Fine sand-----	9	13
Blue sandy clay-----	60	73
Gravel-----	3	76
Soft blue clay-----	64	140
Sand-----	20	160
Gravel-----	6	166
Bedrock-----	14	180

139-78-22cc
 T. C. Casey test hole 12
 Log by Schnell Inc.

<u>Material</u>	<u>Thickness</u> (feet)	<u>Depth</u> (feet)
Topsoil-----	3	3
Sand and small gravel-----	22	25
Blue clay-----	3	28
Sand and lignite-----	3	31
Blue clay-----	12	43
Sand layer-----	1	44
Clay with thin sand and lignite layers-----	44	88
Sand and gravel-----	4	92
Clay, sand and gravel in layers---	57	149
Bedrock (Fort Union Group)-----	31	180

139-78-22cd
 T. C. Casey test hole 11
 Log by Schnell Inc.

<u>Material</u>	<u>Thickness</u> (feet)	<u>Depth</u> (feet)
Topsoil-----	2	2
Dry sand-----	5	7

TABLE 2.--Logs of test holes -- Continued

139-78-22cd, Continued
 T. C. Casey test hole 11
 Log by Schnell Inc.

<u>Material</u>	<u>Thickness</u> (feet)	<u>Depth</u> (feet)
Yellow clay-----	25	32
Gray clay-----	12	44
Gravelly clay-----	1	45
Gray clay, sandy-----	23	68
Gravel with boulders-----	4	72
Sandy clay with sand lenses-----	50	122
Tough clay with some sandy clay layers-----	52	174
Sand-----	4	178
Clay-----	2	180
Soft sandstone-----	25	205
Sandy clay-----	1	206
Sand-----	5	211
Sandy clay layers and sandstone (thin lenses)-----	5	216

139-78-23cda
 Test hole 2010

<u>Formation</u>	<u>Material</u>	<u>Thickness</u> (feet)	<u>Depth</u> (feet)
Glacial drift:			
	Topsoil-----	1	1
	Silt, dark-yellowish-orange, clayey, cohesive, lignite flecks, highly- calcareous, oxidized-----	11	12
	Clay, light-olive-gray, very silty, cohesive, highly-calcareous, oxi- dized-----	15	27
	Silt, dark-greenish-gray, cohesive, abundant lignite flecks, cal- careous-----	5	32
	Sand, very fine to fine, silty to clayey, abundant lignite-----	7	39
	Silt, dark-greenish-gray, clayey, very cohesive, lignite flecks, calcareous-----	23	62

TABLE 2.--Logs of test holes -- Continued

139-78-23cda, Continued
 Test hole 2010

<u>Formation</u>	<u>Material</u>	<u>Thickness</u> (feet)	<u>Depth</u> (feet)
Glacial drift-Continued:			
	Gravel, fine to medium, sandy, angular to well-rounded, a- bundant carbonates, lignite and fossil fragments-----	2	64
	Clay, dark-greenish-gray, silty, very cohesive, calcareous-----	5	69
	Gravel, fine to medium sandy-----	1	70
	Till, dark-greenish-gray, silty to sandy, lignite fragments, calcareous-----	13	83
	Sand, fine, gravelly, unsorted, angular to rounded, abundant carbonates and shale, some lignite-----	5	88
	Till, dark-greenish-gray, silty to gravelly, lignite fragments, cal- careous-----	44	132
	Silt, dark-greenish-gray, clayey to sandy, lignite flakes, calcar- eous-----	47	179
	Sand, very fine to medium, silty, unsorted, lignite fragments-----	47	226
	Gravel, fine to coarse, sandy, un- sorted, angular to well-rounded, abundant brownish pebbles, some carbonates-----	34	260
Fox Hills Sandstone:			
	Clay, dark-greenish-gray, very silty, cohesive, lignite fragments-----	5	265

TABLE 2.--Logs of test holes -- Continued

139-78-24dcd
Test hole 1933

<u>Formation</u>	<u>Material</u>	<u>Thickness</u> (feet)	<u>Depth</u> (feet)
Glacial drift:			
	Topsoil, black-----	1	1
	Clay, light-olive-gray, silty to sandy, cohesive, abundant organic material, calcareous, oxidized-----	10	11
	Clay, medium-dark-gray, silty to sandy, cohesive, calcareous-----	12	23
	Clay, light-olive-gray, silty, co- hesive, lignite flakes, cal- careous-----	44	67
	Gravel, fine to coarse, sandy, subangular to subrounded-----	5	72
	Clay, light-olive-gray, silty, co- hesive, lignite fragments, cal- careous-----	2	74
	Gravel, fine to coarse, sandy, sub- angular to subrounded-----	3	77
	Clay, light-olive-gray, silty, co- hesive, lignite fragments, cal- careous-----	6	83
	Gravel, fine to coarse, sandy, subangular to subrounded-----	5	88
	Clay, light-olive-gray, silty, cohesive, lignite fragments, calcareous-----	26	114
	Gravel, fine to medium, sandy, subangular to rounded; clay, light-olive-gray, silty; inter- bedded-----	7	141
	Gravel, fine, sandy, angular to well-rounded, lignite fragments---	32	173
	Sand, fine to very coarse, angular to well-rounded, abundant quartz--	38	211
Fox Hills Sandstone:			
	Sandstone, medium-gray, very fine to fine-grained, friable, silty and clayey, abundant dark grains--	20	231

TABLE 2.--Logs of test holes -- Continued

139-78-27cbb
 Test hole 2037

<u>Formation</u>	<u>Material</u>	<u>Thickness</u> (feet)	<u>Depth</u> (feet)
Glacial drift:			
	Silt, dark-yellowish-orange, clayey, cohesive, lignite fragments, calcareous-----	20	20
	Silt, dark-yellowish-brown; sand, very fine to medium, oxidized-----	5	25
	Silt, dark-greenish-gray, sandy, lignite fragments, calcareous-----	15	40
	Clay, olive to greenish-black, silty, cohesive, slightly-calcareous-----	10	50
	Silt, olive-gray, sandy, lignite fragments, calcareous-----	30	80
	Silt, olive-gray, very sandy, abundant quartz and lignite-----	24	104
	Till, olive-gray, calcareous-----	7	111
	Till, olive-to dark-greenish-gray, silty to very sandy, lignite fragments, calcareous-----	34	145
	Silt, light-olive to greenish-gray, clayey, cohesive, abundant lignite, calcareous-----	55	200
	Gravel, fine to coarse, sandy, angular to rounded, unsorted-----	45	245
Fox Hills Sandstone:			
	Clay, greenish-gray, very silty, cohesive, indurated, mica flakes-----	10	255

TABLE 2.--Logs of test holes -- Continued

139-78-30cdd
Test hole 2054

<u>Formation</u>	<u>Material</u>	<u>Thickness</u> (feet)	<u>Depth</u> (feet)
Glacial drift:			
	Topsoil, black-----	3	3
	Till, moderate-yellowish-brown, oxidized, calcareous-----	14	17
Hell Creek Formation:			
	Sandstone, very fine to medium, slightly-calcareous, some lig- nite-----	15	32
	Sandstone, very fine to medium, clayey, oxidized-----	5	37
	Clay, olive-gray, silty, indurated--	5	42
	Sandstone, dark-greenish-gray, clayey-----	3	45

139-78-31ddb
Test hole 1864

<u>Formation</u>	<u>Material</u>	<u>Thickness</u> (feet)	<u>Depth</u> (feet)
Glacial drift:			
	Topsoil, black-----	2	2
	Clay, yellowish-brown, silty-----	13	15
	Clay, medium-gray, silty, homo- genous-----	130	145
	Gravel, medium to coarse-----	2	147
Hell Creek Formation:			
	Shale, dark-brown, silty and sandy, carbonaceous, lignite seams; sand- stone, very fine to fine-grained, friable, glauconitic (?)-----	5	1522
	Shale, dark-brownish-gray, silty and sandy, carbonaceous; sandstone, bluish-gray, very fine to fine- grained, clayey, friable-----	16	168

TABLE 2.--Logs of test holes -- Continued

139-78-31ddb, Continued
 Test hole 1864

<u>Formation</u>	<u>Material</u>	<u>Thickness</u> (feet)	<u>Depth</u> (feet)
Fox Hills Sandstone:			
	Sandstone, light-bluish-gray, very fine to fine-grained, friable, scattered glauconite (?) grains---	31	199
	Sandstone, light-bluish-gray, very fine to fine-grained, friable, glauconitic (?), scattered carbonaceous specks-----	6	205
	Shale, light-gray, silty and sandy, interbedded brown fiverous carbonaceous material-----	5	210
	Sandstone, light-gray, very fine to fine-grained, friable, glauconitic (?);shale, light-gray, silty-----	10	220
	Shale, light-gray, silty-----	11	231
	Sandstone, light-gray, very fine to fine-grained, friable, clayey and silty, glauconitic (?)-----	10	241
	Shale, light to medium-gray, silty; shale, dark-brownish-gray-----	37	278
	Shale, light to medium-gray, silty, thin brown carbonaceous streaks---	5	283
	Shale, light to medium-gray, silty; sandstone, dark-greenish-gray, very fine to fine-grained, friable, glauconitic-----	5	288
	Shale, light to medium-gray, silty--	21	309
	Sandstone, dark-greenish-gray, very fine to fine-grained, clayey and silty, friable; shale, medium-gray, silty, indurated from 383-386 feet-----	79	388
	Sandstone, light to dark-greenish-gray, friable, some indurated layers, abundant glauconite grains-----	16	404
	Shale, dark-greenish-gray, very sandy and silty, abundant glauconite-----	5	409

TABLE 2.--Logs of test holes -- Continued

139-78-31ddb, Continued
Test hole 1864

<u>Formation</u>	<u>Material</u>	<u>Thickness</u> (feet)	<u>Depth</u> (feet)
Fox Hills Sandstone-Continued:			
	Shale, dark-greenish-gray, sandy and silty; sandstone, very fine to fine-grained, friable, indurated from 426-428 feet; abundant glauconite-----	19	428

Pie re Shale:

	Shale, dark-gray, silty in parts	44	472
--	----------------------------------	----	-----

139-78-33bbc
Auger hole 6

<u>Formation</u>	<u>Material</u>	<u>Thickness</u> (feet)	<u>Depth</u> (feet)
Glacial drift:			
	Clay, light-olive-gray; sand, fine to medium-----	14	14
	Clay, olive-gray, sandy-----	3	17
	Sand, dark-gray, very fine to medium-----	4	21
	Clay, dark-gray, sandy, silty, lignitic-----	36	57

139-79-18dad
Shot Point 121
Log by Magnolia Petroleum Co.

<u>Material</u>	<u>Thickness</u> (feet)	<u>Depth</u> (feet)
Clay, some gravel and sandstone-----	10	10
Brown clay-----	18	28
Blue clay-----	10	38
Hard sandstone-----	2	40
Blue clay-----	40	80

TABLE 2.--Logs of test holes -- Continued

139-79-19aab
 Shot Point 39
 Log by Magnolia Petroleum Co.

<u>Material</u>	<u>Thickness</u> (feet)	<u>Depth</u> (feet)
Clay-----	4	4
Sand gravel and small boulders-----	10	14
Blue shale-----	45	59
Very hard shale-----	2	61
Blue shale-----	9	70
Sandy blue clay-----	10	80

139-79-22aaa
 Shot Point 55
 Log by Magnolia Petroleum Co.

<u>Material</u>	<u>Thickness</u> (feet)	<u>Depth</u> (feet)
Brown clay-----	7	7
Yellow clay-----	9	16
Blue clay-----	4	20
Sandy blue clay-----	10	30
Blue clay-----	10	40
White, brown, and black clay-----	5	45
Sandy clay-----	5	50
Blue clay-----	24	74
Coal-----	1	75
Blue clay-----	5	80

TABLE 2.--Logs of test holes -- Continued

139-79-24bcc
Test hole 1930

<u>Formation</u>	<u>Material</u>	<u>Thickness</u> (feet)	<u>Depth</u> (feet)
Glacial drift:			
	Clay, dark-yellowish-brown, silty, oxidized, calcareous-----	5	5
	Clay, olive-gray, silty to sandy, lignite fragments, calcareous-----	5	10
	Sand, fine to medium; gravel, fine; unsorted, angular to well-rounded, lignite fragments-----	5	15
	Gravel, fine to medium, sandy, poorly-sorted, subrounded to rounded--	11	26

Hell Creek Formation:

	Clay, greenish-gray; sand, fine, angular; abundant lignite and glauconite-----	11	37
	Clay, moderate-yellowish-brown, sandy, abundant lignite, glauconite and shale-----	5	42

139-79-33aad
U. S. B. R. drill hole 5

<u>Material</u>	<u>Thickness</u> (feet)	<u>Depth</u> (feet)
Topsoil, brown, organic, sandy-----	1	1
Sand, tan, fine, silty, dry, dense--	14	15
Clay (shale) (Fort Union Group) gray, very tough and firm, dry----	19.6	34.6

TABLE 2.--Logs of test holes -- Continued

139-79-35aad1
Test hole 1862

<u>Formation</u>	<u>Material</u>	<u>Thickness</u> (feet)	<u>Depth</u> (feet)
Glacial drift:			
	Topsoil, black-----	1	1
	Clay, brown, silty and sandy-----	14	15
	Sand, medium-gray, fine to medium; clay, gray, silty-----	7	22
	Sand, medium-gray, very fine to fine-----	4	26
	Sand, medium to very coarse; gravel, fine to medium; clayey, pelecypod shells-----	6	32
	Clay, medium-gray, gastropod shells-	31	63
	Clay, light to medium-gray, silty---	21	84
	Clay and sand, interbedded. Clay, medium-gray, silty; sand, gray, very fine to fine-----	21	105
	Sand, medium-gray, very fine to fine; clay, medium-gray, silty, interbedded with sand-----	21	126
	Sand, gray, fine to medium, clayey, abundant lignite fragments-----	16	142
	Gravel, medium to very coarse, a- bundant lignite (lost circulation abandoned hole)-----	5	147

139-79-35aad2
Test hole 1862 A
(50 feet south of aad1)

<u>Formation</u>	<u>Material</u>	<u>Thickness</u> (feet)	<u>Depth</u> (feet)
Glacial drift:			
	Topsoil, black-----	1	1
	Clay, brown, silty to sandy-----	20	21
	Sand gravel. Sand, medium to very coarse; gravel, fine to medium---	10	31
	Clay, light to medium-gray-----	11	42

TABLE 2.--Logs of test holes -- Continued

139-79-35aad2, Continued
 Test hole 1862 A
 (50 feet south of aad1)

<u>Formation</u>	<u>Material</u>	<u>Thickness</u> (feet)	<u>Depth</u> (feet)
Glacial drift-Continued:			
	Clay, light-medium-gray, silty, lignite fragments-----	21	63
	Clay, medium to brownish-gray, silty-----	21	84
	Clay, medium-gray, silty-----	10	94
	Clay and sand, interbedded. Clay, medium-gray, silty; sand, medium- gray, very fine to fine-----	11	105
	Sand, medium-gray, very fine to fine, silty to clayey-----	21	126
	Sand, fine to medium, clayey, a- bundant lignite fragments-----	16	142
	Gravel and sand. Gravel, medium to very coarse; sand, medium to very coarse-----	10	152

139-79-35ca
 U. S. B. R. drill hole 8

<u>Material</u>	<u>Thickness</u> (feet)	<u>Depth</u> (feet)
Clay, brown and gray, plastic, soft-----	13	13
Sand, gray, fine, silty-----	4	17
Clay, gray, silty, firm-----	3	20
Sand, gray, fine, silty, dense-----	10	30

TABLE 2.--Logs of test holes -- Continued

139-79-35cba
U.S.B.R. drill hole 7

<u>Material</u>	<u>Thickness</u> (feet)	<u>Depth</u> (feet)
Clay, brown, plastic, soft-----	11	11
Clay, gray, organic, plastic, soft---	4	15
Sand, gray, fine to coarse, fine gravels-----	3	18
Sand, gray, fine, silty-----	8	26
Sand, gray, fine, few gravels-----	9	35
Sand, gray, fine with lignite part- icles, dense-----	14.8	49.8

139-80-2bba
Shot Point 201
Log by Magnolia Petroleum Co.

<u>Material</u>	<u>Thickness</u> (feet)	<u>Depth</u> (feet)
Yellow clay-----	24	24
Sandy clay-----	45	69
Sand-----	9	78
Blue clay-----	12	90

139-80-3abb
Test hole 1981

<u>Formation</u>	<u>Material</u>	<u>Thickness</u> (feet)	<u>Depth</u> (feet)
Glacial drift:			
	Topsoil-----	2	2
	Gravel, fine to medium, sandy, un- sorted, subrounded, to rounded----	3	5
	Till, grayish-orange, silty to sandy, lignite fragments, cal- careous, oxidized-----	15	20
	Till, dark-greenish-gray, silty to sandy, lignite fragments, cal- careous-----	7	27

TABLE 2.--Logs of test holes -- Continued

139-80-3abb, Continued
Test hole 1981

<u>Formation</u>	<u>Material</u>	<u>Thickness</u> (feet)	<u>Depth</u> (feet)
Glacial drift-Continued:			
	Sand, very fine to coarse, silty to gravelly, predominately quartz--	4	31
	Till, dark-greenish-gray, shale and lignite, calcareous-----	8	39
Cannonball Formation:			
	Sand, very fine to medium, predominately quartz, lignite fragments-----	6	45
	Sand, very fine to fine, clayey, predominately quartz, some lignite-----	10	55

139-80-4bab
Shot Point 159
Log by Magnolia Petroleum Co.

<u>Material</u>	<u>Thickness</u> (feet)	<u>Depth</u> (feet)
Clay-----	3	3
Sand and gravel-----	12	15
Yellow sandy clay-----	13	28
Sand with gravel streaks-----	37	65
Blue sandy clay-----	15	80

139-80-9ada
Shot Point 63
Log by Magnolia Petroleum Co.

<u>Material</u>	<u>Thickness</u> (feet)	<u>Depth</u> (feet)
Clay, some gravel and small boulders-	10	10
Yellow sandy clay-----	17	27

TABLE 2.--Logs of test holes -- Continued

139-80-9ada, Continued
 Shot Point 63
 Log by Magnolia Petroleum Co.

<u>Material</u>	<u>Thickness</u> (feet)	<u>Depth</u> (feet)
Blue clay-----	15	42
Hard ledge-----	2	44
Sandy blue clay-----	21	65
Blue clay-----	15	80

139-80-10aaa2
 Shot Point 75
 Log by Magnolia Petroleum Co.

<u>Material</u>	<u>Thickness</u> (feet)	<u>Depth</u> (feet)
Sandy clay-----	20	20
Sand and gravel-----	21	41
Blue clay-----	39	80

139-80-22abb
 Shot Point 129
 Log by Magnolia Petroleum Co.

<u>Material</u>	<u>Thickness</u> (feet)	<u>Depth</u> (feet)
Clay-----	8	8
Yellow clay, some sand and gravel----	7	15
Blue clay, scattered gravel-----	25	40
Firm blue clay-----	40	80

TABLE 2.--Logs of test holes -- Continued

139-80-22ddd
Test hole 2059

<u>Formation</u>	<u>Material</u>	<u>Thickness</u> (feet)	<u>Depth</u> (feet)
Colluvium:			
	Topsoil, sandy-----	1	1
	Clay, yellowish-brown, sandy, highly-oxidized, calcareous-----	6	7
Glacial drift:			
	Gravel, fine to medium with a little coarse material, rounded-----	5	12
Cannonball Formation:			
	Sand, dark-greenish-gray, fine, clayey and silty-----	9	21

139-80-28aad
Shot Point 148
Log by Magnolia Petroleum Co.

<u>Material</u>	<u>Thickness</u> (feet)	<u>Depth</u> (feet)
Sandy clay-----	6	6
Gravel and small boulders-----	2	8
Clay-----	14	22
Blue clay-----	21	43
Very hard clay-----	2	45
Blue sand-----	5	50
Blue clay-----	30	80

TABLE 2.--Logs of test holes -- Continued

139-80-35ddd
Test hole 2060

<u>Formation</u>	<u>Material</u>	<u>Thickness</u> (feet)	<u>Depth</u> (feet)
Alluvium:			
	Topsoil, black, clayey-----	1	1
	Clay, yellowish-brown, silty-----	10	11
	Clay dark-greenish-gray, silty and sandy, calcareous-----	5	17
Glacial drift:			
	Gravel, fine to medium, rounded-----	1	18
	Clay, dark-greenish-gray, sandy, soft, calcareous-----	6	24
	Clay, olive-gray, smooth, plastic, calcareous-----	42	68
	Gravel, fine to medium, rounded-----	2	70
Hell Creek Formation:			
	Clay, dark-greenish-gray, silty to sandy, micaceous-----	14	84

139-80-36bcd
U.S.B.R. drill hole 2

<u>Material</u>	<u>Thickness</u> (feet)	<u>Depth</u> (feet)
Topsoil-----	1	1
Sand, brown, clayey, dense-----	5	6
Clay, gray, sandy-----	4	10
Clay, brown, and gray, soft, plastic-	9	19
Clay, brown and gray, sandy, soft----	13	32
Clay, gray, plastic-----	3	35
Silt, gray, clayey, soft-----	8	43
Clay, gray, sandy-----	10	53
Sandy clay (till?), gray and brown with coarse gravel-----	10.5	63.5
Shale, gray, sandy-----	1.5	65

TABLE 2.--Logs of test holes -- Continued

139-81-2cbb
 Test hole 1980

<u>Formation</u>	<u>Material</u>	<u>Thickness</u> (feet)	<u>Depth</u> (feet)
Glacial drift:			
	Topsoil, sandy-----	7	7
	Sand, moderate-yellowish-brown, very fine to medium, silty to clayey, oxidized-----	5	12
	Sand, fine to coarse, lignite frag- ments-----	16	28
	Clay, dark-greenish-gray, very silty, cohesive, lignite flecks, cal- careous-----	4	32
	Sand, fine to coarse, lignite flakes-	20	52
	Sand, fine to very coarse, clayey, lignite and shale fragments-----	7	59
	Sand, fine to coarse, angular to rounded, lignite wood and fossil fragments-----	6	65
	Sand, fine to coarse, clayey-----	3	68
	Sand, fine to coarse, silty, angular to rounded-----	9	77
	Clay, light-olive-gray, silty-----	17	94
	Boulders and cobbles-----	12	106
Hell Creek Formation:			
	Clay, greenish-gray, silty, cohesive, lignite and mica flakes-----	4	110

TABLE 2.--Logs of test holes -- Continued

140-75-1aaa
 Test hole 2049A

<u>Formation</u>	<u>Material</u>	<u>Thickness</u> (feet)	<u>Depth</u> (feet)
Glacial drift:			
	Topsoil-----	1	1
	Till, grayish-black, predominately shale-----	4	5
	Till, dusky-yellow, highly-calcareous, oxidized-----	6	11
	Till, moderate-yellowish-brown, cal- careous, oxidized-----	13	24
	Till, olive-gray, calcareous-----	45	69
	Sand, coarse-----	1	70
	Till, olive-gray, lignite fragments, calcareous-----	7	77
	Gravel, fine to coarse, subrounded---	8	85
	Gravel, fine to coarse; sand, med- ium to coarse; subrounded-----	37	122
	Silt, olive-gray, clayey; sand, very fine; calcareous-----	16	138
	Gravel, fine to coarse, subrounded---	12	138
	Gravel, fine to coarse, subrounded---	12	150
	Sand, medium to coarse, some gran- ules subrounded-----	19	169
	Gravel, granular to cobbles, round- ed-----	10	179
Hell Creek Formation:			
	Shale, dusky-yellowish-brown, lig- nitic, oxidized-----	5	184
	Sandstone, dark-greenish-gray, very fine to fine-----	5	189

TABLE 2.--Logs of test holes -- Continued

140-75-12cdd
Test hole 2049

<u>Formation</u>	<u>Material</u>	<u>Thickness</u> (feet)	<u>Depth</u> (feet)
Glacial drift:			
	Till, moderate-olive-brown, sandy, oxidized, calcareous-----	17	17
	Till, olive-gray, abundant sandstone and shale fragments-----	29	46
	Silt, olive-gray, very clayey, plastic-----	4	50
	Gravel, fine to medium, subrounded; sand, coarse; poorly-sorted-----	10	60
	Silt, olive- black, clayey, plastic, cohesive-----	3	63
	Sand, olive-gray, fine to medium, subangular to subrounded-----	17	80
	Silt, olive-gray, very clayey, smooth, plastic-----	29	109
	Gravel, fine to very coarse; sand, medium to coarse; subangular to subrounded; organic soil zone around 150 feet-----	71	180
	Gravel, very coarse; sand, very coarse; subangular to subrounded---	4	184
Fox Hills Sandstone:			
	Silt, bluish-green, clayey-----	5	189

140-75-21ddd
Test hole 2003

<u>Formation</u>	<u>Material</u>	<u>Thickness</u> (feet)	<u>Depth</u> (feet)
Glacial drift:			
	Till, moderate-yellowish-brown, lignite fragments, oxidized, highly-calcareous-----	22	22

TABLE 2.--Logs of test holes --Continued

140-75-21ddd, Continued
Test hole 2003

<u>Formation</u>	<u>Material</u>	<u>Thickness</u> (feet)	<u>Depth</u> (feet)
Glacial drift-Continued:			
	Till, dark-greenish-gray, lignite fragments, calcareous-----	34	56
	Clay, dark-greenish-gray, silty, cohesive, calcareous-----	9	65
	Sand, very fine to coarse, oxidized, abundant lignite-----	1	66
Hell Creek Formation:			
	Sandstone, moderate-yellowish-brown, silty; clay, dark-yellowish- orange, silty, oxidized-----	17	83
	Clay, grayish-green, sandy, indurated, black and green grains-----	7	90

140-75-24ddd
Test hole 2049B

<u>Formation</u>	<u>Material</u>	<u>Thickness</u> (feet)	<u>Depth</u> (feet)
Glacial drift:			
	Sand, medium; gravel, coarse; ang- ular to subrounded-----	9	9
	Till, dark-greenish-gray, abundant shale and lignite calcareous-----	26	35
	Silt, dark-greenish-gray, clayey to sandy, highly-calcareous-----	5	40
	Till, dark-greenish-gray, with minor layers of medium to coarse sand, calcareous-----	13	53
	Till, dark-greenish-gray, abundant shale and lignite, calcareous-----	39	92
	Gravel, coarse; sand, medium to coarse; angular to rounded-----	14	106
	Till, dark-greenish-gray, abundant gravel, calcareous-----	20	126

TABLE 2.--Logs of test holes -- Continued

140-75-24ddd, Continued
 Test hole 2049B

<u>Formation</u>	<u>Material</u>	<u>Thickness</u> (feet)	<u>Depth</u> (feet)
Glacial drift-Continued:			
	Gravel, fine to coarse, clayey, abundant shale pebbles-----	10	136
Hell Creek Formation:			
	Shale, dusky-brown, silty to sandy, lignitic-----	6	142
	Shale, grayish-olive, very silty to sandy, partially-indurated-----	5	147

140-75-32dcc
 Test hole 2049C

<u>Formation</u>	<u>Material</u>	<u>Thickness</u> (feet)	<u>Depth</u> (feet)
Glacial drift:			
	Topsoil, black-----	3	3
	Clay, light-olive-gray, sandy, highly- calcareous, oxidized-----	3	6
	Gravel, very coarse; sand, medium to coarse; rounded, oxidized-----	2	8
	Silt, dark-yellowish-brown, some lignite specks, calcareous, oxi- dized-----	1	9
	Till, moderate-yellowish-brown, a- bundant shale pebbles, calcareous, oxidized-----	13	22
	Till, dark-greenish-gray, abundant shale pebbles, calcareous-----	20	42
	Sand, very fine to very coarse-----	2	44
	Till, dark-greenish-gray, abundant shale, calcareous-----	20	64

TABLE 2.--Logs of test holes -- Continued

140-75-32dcc, Continued
Test hole 2049C

<u>Formation</u>	<u>Material</u>	<u>Thickness</u> (feet)	<u>Depth</u> (feet)
Hell Creek Formation:			
	Shale, grayish-brown, silty, lignitic, oxidized-----	5	69
	Siltstone, olive-gray, sandy, some lignite fragments-----	4 1/2	73 1/2

140-75-35add
Test hole 2033

<u>Formation</u>	<u>Material</u>	<u>Thickness</u> (feet)	<u>Depth</u> (feet)
Glacial drift:			
	Topsail-----	3	3
	Till, olive-gray, gravelly, oxidized-	4	7
	Till, dark-greenish-gray, gravelly, lignite fragments, calcareous-----	16	23
	Sand, fine to very coarse, gravelly, unsorted, rounded, abundant shale pebbles-----	7	30
	Till, dark-greenish-gray, gravelly, lignite fragments, calcareous-----	28	58

Hell Creek Formation:

	Sandstone, olive-gray, very fine grains, silty, indurated, contains some mica and lignite flakes-----	4	62
	Sandstone, dark-yellowish-brown, very fine-grained, silty, indurated, abundant lignite grains---	8	70
	Claystone, grayish-blue-green, silty, indurated, lignite fragments-----	5	75

TABLE 2.--Logs of test holes -- Continued

140-76-14daa
Test hole 2019

<u>Formation</u>	<u>Material</u>	<u>Thickness</u> (feet)	<u>Depth</u> (feet)
Glacial drift:			
	Topsoil, black-----	2	2
	Clay, grayish-orange, silty, oxidized, calcareous-----	3	5
	Till, moderate-yellowish-brown, abundant shale, lignite fragments, oxidized, calcareous-----	15	20
	Till, dark-greenish-gray, abundant shale, limestone and lignite, calcareous-----	10	30
	Silt, olive-gray, cohesive, lignite fragments, calcareous-----	5	35
	Silt, dark-greenish-gray, clayey, calcareous-----	16	51
	Till, dark-greenish-gray, abundant shale and limestone, lignite fragments, calcareous-----	35	86
	Sand, very fine to medium, silty, unsorted, abundant lignite-----	20	106

Hell Creek Formation:

	Sandstone, grayish-blue-green, silty, abundant black and green grains----	14	120
--	---	----	-----

140-76-18bbc
Test hole 1935

<u>Formation</u>	<u>Material</u>	<u>Thickness</u> (feet)	<u>Depth</u> (feet)
Glacial drift:			
	Clay, brownish-gray, silty and sandy-----	5	5
	Clay, medium to dark-gray, sandy and silty-----	4	9
	Gravel, medium to coarse; sand, coarse to very coarse; shale fragments-----	14	23

TABLE 2.--Logs of test holes -- Continued

140-76-18bbc, Continued
Test hole 1935

<u>Formation</u>	<u>Material</u>	<u>Thickness</u> (feet)	<u>Depth</u> (feet)
Cannonball Formation:			
	Claystone, dusky-blue-green, silty and sandy, mica flakes, glauconite grains-----	8	31
	Claystone, brownish-gray, silty, carbonaceous-----	21	52
Hell Creek Formation:			
	Sandstone, light-gray, friable, lignitic layers-----	12	64
	Claystone, brownish-gray, silty-----	20	84
	Sandstone, dark-greenish-gray, mica flakes, carbonaceous, abundant glauconite grains-----	10	94

140-76-25ccc
Test hole 2018

<u>Formation</u>	<u>Material</u>	<u>Thickness</u> (feet)	<u>Depth</u> (feet)
Glacial drift:			
	Topsoil, brownish-black, very silty---	4	4
	Silt, medium-light-gray, cohesive, abundant snail shells, highly-calcareous-----	2	6
	Till, moderate-yellowish-orange, abundant limestone and shale, lignite fragments, oxidized, calcareous-----	14	20
	Till, dark-greenish-gray, predominately limestone and shale, abundant lignite fragments, calcareous-----	38	58
	Sand, fine to very coarse, gravelly, subangular to rounded-----	25	83

TABLE 2.--Logs of test hole -- Continued

140-76-25ccc, Continued
Test hole 2018

<u>Formation</u>	<u>Material</u>	<u>Thickness</u> (feet)	<u>Depth</u> (feet)
Hell Creek Formation:			
	Sandstone, medium-bluish-gray, very fine to fine-grained, silty, some lignite and glauconite grains-----	7	90

140-76-32aaa
Test hole 2026

<u>Formation</u>	<u>Material</u>	<u>Thickness</u> (feet)	<u>Depth</u> (feet)
Glacial drift:			
	Till, dusky-yellow, sandy, calcareous, oxidized-----	5	5
	Gravel, fine to medium, abundant limestone, oxidized-----	6	11
	Sand, very fine to fine, silty-----	12	23
	Clay, olive-gray, very silty, plastic, cohesive, calcareous-----	18	41
	Till, olive-gray, silty to sandy, calcareous-----	7	48

Cannonball Formation:

	Shale, olive-gray, fissile to compact-----	15	63
	Shale, olive-black, silty, fissile---	32	95
	Sandstone, dark-greenish-gray, fine grained, silty and clayey, scattered blue-green grains, carbonaceous material-----	5	100
	Sandstone, dark-greenish-gray, friable, silty, abundant green grains-----	5	105
	Shale, greenish-gray, sandy, cohesive, plastic; sandstone, friable-----	26	131
	Shale, greenish-gray to brownish-black, silty-----	9	140

TABLE 2.--Logs of test holes -- Continued

140-76-32aaa, Continued
Test hole 2026

<u>Formation</u>	<u>Material</u>	<u>Thickness</u> (feet)	<u>Depth</u> (feet)
Cannonball Formation-Continued:			
	Shale, light-olive-gray, silty, cohesive-----	21	161
	Sandstone, greenish-gray, fine to very fine grained, some dark-grains, abundant blue-green grains-----	16	177
	Shale, brownish-black, carbonaceous, lignitic, silty-----	7	184
	Shale, greenish-gray, silty, cohesive, plastic-----	4	188
	Shale, brownish-black, carbonaceous, lignitic, abundant wood material--	6	194
Hell Creek Formation:			
	Sandstone, greenish-gray, fine to very fine-grained, silty and clayey, scattered blue-green grains-----	6	200
	Sandstone, medium-bluish-gray, fine-grained, friable, silty, clayey, scattered carbonaceous material and blue-green grains-----	10	210

140-78-14aaa
Test hole 2008

<u>Formation</u>	<u>Material</u>	<u>Thickness</u> (feet)	<u>Depth</u> (feet)
Glacial drift:			
	Topsoil, black-----	2	2
	Till, moderate-yellowish-brown, oxidized, very calcareous-----	4	6
	Gravel, fine to coarse, sandy, sub-rounded to rounded, unsorted, oxidized-----	7	13

TABLE 2.--Logs of test holes -- Continued

140-78-14aaa, Continued
Test hole 2008

<u>Formation</u>	<u>Material</u>	<u>Thickness</u> (feet)	<u>Depth</u> (feet)
Glacial drift:			
	Gravel, fine to coarse, sandy, sub- rounded to well-rounded, unsorted, fossil shell fragments-----	6 1/2	19 1/2
Cannonball Formation:			
	Sand, greenish-black, indurated; white, green, and black grains-----	10 1/2	30

140-78-32ddd
Test hole 1931

<u>Formation</u>	<u>Material</u>	<u>Thickness</u> (feet)	<u>Depth</u> (feet)
Glacial drift:			
	Topsoil-----	1	1
	Clay, dark-yellowish-brown, silty to sandy, oxidized, calcareous----	41	42
Hell Creek Formation:			
	Clay, light-olive-gray, very silty, indurated, lignite chips-----	12	54
	Clay, greenish-gray, silty to sandy, indurated, abundant lignite-----	9	63

TABLE 2.--Logs of test holes -- Continued

140-78-34acd
Test hole 2027

<u>Formation</u>	<u>Material</u>	<u>Thickness</u> (feet)	<u>Depth</u> (feet)
Glacial drift:			
	Topsoil, sandy, black-----	2	2
	Sand, very fine to very coarse, unsorted, subrounded, oxidized-----	4	6
	Silt, dark-yellowish-orange, mica and lignite flakes, highly-calcareous, oxidized-----	21	27
	Clay, olive-gray, silty, cohesive, calcareous-----	9	36

Hell Creek Formation:

	Sand, fine to medium, well-sorted, abundant green and black grains---	24	60
--	---	----	----

140-78-36bba
Test hole 2009

<u>Formation</u>	<u>Material</u>	<u>Thickness</u> (feet)	<u>Depth</u> (feet)
Glacial drift:			
	Topsoil, black-----	2	2
	Sand, medium to very coarse, gravelly, unsorted, angular to subrounded, oxidized-----	8	10
	Gravel, fine to medium, sandy, subangular to well-rounded, oxidized-	2	12
	Silt, moderate-yellowish-brown, cohesive, lignite flecks, calcareous-----	1	13
	Silt, dark-greenish-gray, cohesive, lignite fragments, calcareous-----	3	16
	Clay, dark-greenish-gray, cohesive, calcareous-----	17	33
	Sand, fine to very coarse, unsorted, angular to rounded, abundant shale, limestone and lignite, some shell fragments-----	6	39

TABLE 2.--Logs of test holes -- Continued

140-78-36bba, Continued
Test hole 2009

<u>Formation</u>	<u>Material</u>	<u>Thickness</u> (feet)	<u>Depth</u> (feet)
Glacial drift-Continued:			
	Gravel, fine to medium, sandy, unsorted, rounded; clay layers----	5	44
	Clay, light-olive-gray, silty, cohesive, calcareous-----	32	76
	Gravel, fine to medium, sandy, un- sorted, subrounded to well- rounded-----	1	77
	Sand, fine to coarse, subangular to subrounded, poorly-sorted, lignite fragments-----	7	84
	Cobbles and boulders-----	2	86
Hell Creek Formation:			
	Sandstone, olive-gray, mica flakes, glauconitic-----	19	105

140-79-10cbb
Test hole 2038

<u>Formation</u>	<u>Material</u>	<u>Thickness</u> (feet)	<u>Depth</u> (feet)
Tongue River Formation:			
	Sandstone, moderate-yellowish- brown, and moderate-olive-brown, medium-grained, some coarse sand grains in the first five feet, abundant dark heavy minerals, oxidized, friable-----	24	24
	Shale, moderate-yellowish-brown, and light-olive-gray, silty, cohesive, calcareous-----	18	42
	Shale and sand interbedded, light- olive-gray, silty-----	21	63
	Shale, dark-yellowish-orange, silty, compact-----	10	73

TABLE 2.--Logs of test holes -- Continued

140-79-10cbb, Continued
Test hole 2038

<u>Formation</u>	<u>Material</u>	<u>Thickness</u> (feet)	<u>Depth</u> (feet)
Tongue River Formation-Continued:			
	Sandstone, light-olive-gray, indurated, medium to fine-grained, mostly quartz, abundant dark heavy minerals-----	1	74
	Shale, dark-yellowish-orange, silty-	10	84
	Sandstone; grayish-olive, medium-grained, friable; sand, fine to coarse; abundant carbonate and dark minerals, scattered yellow-green grains-----	16	100

Cannonball Formation:

	Siltstone, dark-gray to olive-gray, sandy, interbedded, very fine grained, sand and lignite particles-----	15	115
--	--	----	-----

140-80-29cbb
Test hole 1982

<u>Formation</u>	<u>Material</u>	<u>Thickness</u> (feet)	<u>Depth</u> (feet)
Glacial drift:			
	Sand, fine to very fine, silty, lignite fragments, oxidized, highly-calcareous-----	11	11
	Gravel, fine to medium, sandy, angular to rounded, abundant snail shells, oxidized-----	3	14
Cannonball Formation:			
	Shale, olive-gray, very silty, mica flakes-----	6	20

TABLE 2.--Logs of test holes -- Continued

140-81-5aaa
Test hole 1983

<u>Formation</u>	<u>Material</u>	<u>Thickness</u> (feet)	<u>Depth</u> (feet)
Glacial drift:			
	Topsoil, dark-yellowish-brown, sandy to silty-----	4	4
	Sand, light-olive-gray, very fine to medium; silt, clayey in layers; lignite fragments, calcareous-----	16	20
	Sand, medium to coarse, sorted, subangular, lignite fragments-----	13	33
	Lignite, rounded, wood fragments----	1	34
	Sand, medium to very coarse, sorted, subangular, lignite fragments-----	19	53
	Sand, very fine to medium, sorted, subangular, lignite fragments-----	29	82
	Gravel, fine to medium, sandy, unsorted, abundant yellowish pebbles, possibly preglacial-----	23	105

141-75-21ddd
Test hole 2002

<u>Formation</u>	<u>Material</u>	<u>Thickness</u> (feet)	<u>Depth</u> (feet)
Glacial drift:			
	Topsoil, black-----	6	6
	Clay, yellowish-gray, very silty, cohesive, oxidized, highly-cal- careous-----	4	10
	Silt, dark-yellowish-orange, oxi- dized, highly-calcareous-----	7	17
	Silt, dark-greenish-gray, highly calcareous-----	6	23
	Sand, very fine to coarse, silty, subrounded to well-rounded, lig- nite fragments, highly-calcareous-	3	26
	Till, dark-greenish-gray, abundant shale and lignite fragments, cal- careous-----	64	90

TABLE 2.--Logs of test holes -- Continued

141-75-21ddd, Continued
Test hole 2002

<u>Formation</u>	<u>Material</u>	<u>Thickness</u> (feet)	<u>Depth</u> (feet)
Glacial drift-Continued:			
	Gravel, fine to medium, sandy, angular to rounded, oxidized-----	3	93
Cannonball Formation:			
	Silt, dusky-yellow to brownish- black, sandy, abundant lignite, oxidized-----	12	105

141-76-16bba
Test hole 1998

<u>Formation</u>	<u>Material</u>	<u>Thickness</u> (feet)	<u>Depth</u> (feet)
Glacial drift:			
	Gravel, fine to medium, very sandy, subangular to rounded, unsorted, oxidized-----	13	13
	Sand, fine to very coarse, gravelly, poorly-sorted, subrounded, lignite fragments-----	10	23
	Till, olive-black, slightly-cal- careous, lignite fragments-----	20	43
Cannonball Formation:			
	Clay, dusky-yellowish-green to greenish-black, very sandy, co- hesive, mica flakes-----	17	60

TABLE 2.--Logs of test holes -- Continued

141-76-28ada
Test hole 2000

<u>Formation</u>	<u>Material</u>	<u>Thickness</u> (feet)	<u>Depth</u> (feet)
Glacial drift:			
	Till, olive-gray, sandy, highly-calcareous-----	9	9
	Sand, very fine to very coarse, clayey, unsorted; gravel, fine-----	12	21
	Till, dark-greenish-gray, lignite fragments, calcareous-----	35	56
Cannonball Formation:			
	Silt, dark-greenish-gray, sandy, cohesive, abundant very fine sand grains (glauconitic)-----	4	60

141-76-29ccd
Test hole 2001

<u>Formation</u>	<u>Material</u>	<u>Thickness</u> (feet)	<u>Depth</u> (feet)
Glacial drift:			
	Clay, yellowish-gray, silty, cohesive, highly-calcareous, oxidized-----	4	4
	Gravel, fine to medium, sandy, unsorted, subrounded, abundant carbonates-----	9	13
	Sand, fine to very coarse, gravelly, unsorted, subangular to rounded, abundant shale, some lignite-----	29	42
	Clay, light-olive-gray, silty, cohesive, calcareous-----	13	55
Cannonball Formation:			
	Sandstone, very fine-grained, silty to clayey, glauconite grains-----	20	75

TABLE 2.--Logs of test holes -- Continued

141-77-1cdd
Test hole 1999

<u>Formation</u>	<u>Material</u>	<u>Thickness</u> (feet)	<u>Depth</u> (feet)
Glacial drift:			
	Sand, fine to very coarse, gravelly, unsorted, angular to rounded, some shell fragments, oxidized-----	12	12
	Gravel, fine to medium, sandy, unsorted, subrounded to rounded, abundant carbonates, oxidized-----	15	27
	Gravel, fine to very coarse, sandy, unsorted, angular to rounded, abundant shale and carbonates-----	3	30
Cannonball Formation:			
	Shale, dark-greenish-gray, very silty, slightly indurated-----	15	45

141-77-26aaa
Shot Point 30
Log by Magnolia Petroleum Co.

<u>Material</u>	<u>Thickness</u> (feet)	<u>Depth</u> (feet)
Yellow clay and boulders-----	28	28
Hard ledge-----	2	30
Yellow clay-----	6	36
Blue shale-----	14	50
Hard ledge-----	4	54
Blue shale-----	26	80

TABLE 2.--Logs of test holes -- Continued

141-78-5ddd
Test hole 2006

<u>Formation</u>	<u>Material</u>	<u>Thickness</u> (feet)	<u>Depth</u> (feet)
Glacial drift:			
	Gravel, fine to coarse, sandy, unsorted, subangular to subrounded, abundant carbonates and fossil shells, oxidized-----	4	4
Cannonball Formation:			
	Clay, grayish-orange, very silty, cohesive, mica flakes, oxidized-----	2	6
	Clay, greenish-gray, very silty to sandy, indurated, mica flakes, lignite in streaks-----	9	15

141-78-35bbb
Test hole 2007

<u>Formation</u>	<u>Material</u>	<u>Thickness</u> (feet)	<u>Depth</u> (feet)
Glacial drift:			
	Topsoil, black-----	1	1
	Sand, very fine to medium, clayey, fossil fragments, oxidized-----	2	3
	Gravel, fine to medium, sandy, subrounded to angular, calcareous, oxidized-----	6	9
	Gravel, fine to medium, very silty, abundant organic material-----	3	12
Cannonball Formation:			
	Clay, dark-greenish-gray, silty, indurated, abundant mica flakes----	3	15

TABLE 2.--Logs of test holes -- Continued

141-80-36abd
Test hole 2004

<u>Formation</u>	<u>Material</u>	<u>Thickness</u> (feet)	<u>Depth</u> (feet)
Glacial drift:			
	Sand, very fine to medium, very clayey, highly-calcareous, oxidized-----	4	4
	Gravel, fine to medium, very sandy, unsorted, abundant fossil shells---	5	9
Cannonball Formation:			
	Siltstone, greenish to dark-greenish-gray, indurated, lignite fragments-----	6	15

142-75-15cda
Test hole 1994

<u>Formation</u>	<u>Material</u>	<u>Thickness</u> (feet)	<u>Depth</u> (feet)
Glacial drift:			
	Sand, fine to coarse, clayey to gravelly, well-sorted, sub-rounded; cobble and boulders; oxidized-----	15	15
	Till, olive-gray, silty to very sandy, calcareous-----	22	37
	Till, dark-greenish-gray, silty to gravelly, lignite fragments, calcareous-----	59	96
	Sand, fine, silty to clayey, lignite fragments-----	16	112
Cannonball Formation:			
	Clay, brownish-black, silty to sandy, lignite and organic material-----	2	114
	Sand, grayish-blue-green, very fine to medium, quartz and green grains-----	6	120

TABLE 2.--Logs of test holes -- Continued

142-75-19ccb
Test hole 1995

<u>Formation</u>	<u>Material</u>	<u>Thickness (feet)</u>	<u>Depth (feet)</u>
Glacial drift:			
	Topsoil, black-----	2	2
	Till, light-olive-gray, silty to sandy, highly-calcareous, oxi- dized-----	6	8
	Clay, medium-bluish-gray, very silty, cohesive, highly-calcareous, some snail shells-----	4	12
	Peat, brownish-black, predominately organic material, abundant snail shells-----	16	28
	Gravel, fine to medium, very sandy, unsorted, subangular to rounded; sand, medium to very coarse-----	14	42
	Till, olive-gray, silty to sandy, highly-calcareous-----	16	58
	Sand, fine to coarse, unsorted, subrounded, some clay-----	70	128
	Sand, very fine to very coarse, clayey, angular to rounded, lignite fragments-----	45	173
	Till, olive-gray, very sandy-----	8	181
	Gravel, granular, subrounded, sandy-----	15	196
Hell Creek Formation:			
	Clay, brownish-black, silty, co- hesive, mica flakes-----	14	210

TABLE 2.--Logs of test holes -- Continued

142-75-22acc
Test hole 2045

<u>Formation</u>	<u>Material</u>	<u>Thickness</u> (feet)	<u>Depth</u> (feet)
Glacial drift:			
	Sand, very fine to very coarse, clayey; gravel, medium, oxidized---	11	11
	Silt, medium-bluish-gray, cohesive, lignite flecks, calcareous-----	19	30
	Silt, medium-bluish-gray; sand, very fine, calcareous-----	33	63
	Silt, medium-bluish-gray, sandy, calcareous, cohesive between 75-77 and 82-120 feet-----	57	120
	Till, dark-greenish-gray, silty, lignite fragments, calcareous-----	42	162
	Gravel, fine to medium, poorly-sorted, angular to rounded, sandy-----	8	170
	Till, olive-gray, sandy, calcareous-----	1	171
	Gravel, fine to medium, poorly-sorted, angular to rounded, sandy-----	1	172
Hell Creek Formation:			
	Sandstone, grayish-blue-green, very fine to medium-grained, clayey matrix, unsorted, becoming darker with depth and containing more lignite-----	23	195

TABLE 2.--Logs of test holes -- Continued

142-76-3dda
Test hole 1997

<u>Formation</u>	<u>Material</u>	<u>Thickness</u> (feet)	<u>Depth</u> (feet)
Glacial drift:			
	Topsoil, black-----	1	1
	Clay, dusky-yellow, silty, cohesive, oxidized, highly-calcareous-----	5	6
	Gravel, fine, very sandy, unsorted, angular to rounded, abundant shale-----	14	20
	Till, dark-greenish-gray, lignite fragments, slightly-calcareous-----	25	45
	Gravel, fine to coarse, angular to subangular, unsorted, abundant limestone-----	12	57
Cannonball Formation:			
	Clay, light-olive-gray, silty, co- hesive to indurated-----	18	75

142-76-7aaa
Test hole 1978

<u>Formation</u>	<u>Material</u>	<u>Thickness</u> (feet)	<u>Depth</u> (feet)
Glacial drift:			
	Topsoil-----	1	1
	Sand, medium to very coarse, unsorted, subrounded; gravel, granular-----	3	4
	Till, moderate-yellowish-brown, silty to sandy, lignite fragments, oxi- dized, calcareous-----	10	14
	Till, olive-gray, silty to sandy, lignite fragments, calcareous-----	22	36

TABLE 2.--Logs of test holes -- Continued

142-76-7aaa, Continued
Test hole 1978

<u>Formation</u>	<u>Material</u>	<u>Thickness</u> (feet)	<u>Depth</u> (feet)
Cannonball Formation:			
	Shale, olive-gray, calcareous-----	7	43
	Shale, olive-gray, silty-----	10	53
	Sandstone, greenish-gray, very fine to fine-grained, lignite and mica flakes, calcareous-----	22	75
	Shale, olive-gray, silty, calcareous-	6	81
	Sandstone, dark-greenish-gray, very fine to medium-grained, silty, glauconitic-----	4	85
	Shale, olive-gray, very silty to sandy-----	10	95
	Sandstone, dark-greenish-gray, very fine to medium-grained, silty, glauconitic-----	10	105

142-76-22ddd
Test hole 2024

<u>Formation</u>	<u>Material</u>	<u>Thickness</u> (feet)	<u>Depth</u> (feet)
Glacial drift:			
	Clay, dark-yellowish-orange, silty, calcareous-----	4	4
	Sand, very fine to very coarse, un- sorted, gravel, fine to medium, subrounded; clay, yellowish- orange; lignite fragments-----	8	12
	Clay, yellowish-orange, sandy-----	11	23
	Sand, very fine to medium, silty, rounded, abundant shale, limestone and lignite flecks-----	34	57
Cannonball Formation:			
	Clay, dark-greenish-gray, silty, indurated, highly-calcareous-----	18	75

TABLE 2.--Logs of test holes -- Continued

142-76-23bcb
Test hole 1996

<u>Formation</u>	<u>Material</u>	<u>Thickness</u> (feet)	<u>Depth</u> (feet)
Glacial drift:			
	Topsoil, yellow-orange-----	1	1
	Clay, olive-black, silty, cohesive---	5	6
	Gravel, fine to medium, sandy, sub- angular, predominately limestone; sand, fine to very coarse, sub- rounded, predominately quartz-----	17	23
Cannonball Formation:			
	Clay, brownish-black, silty, co- hesive to indurated-----	7	30

142-79-26ddd
Test hole 2005

<u>Formation</u>	<u>Material</u>	<u>Thickness</u> (feet)	<u>Depth</u> (feet)
Glacial drift:			
	Topsoil-----	1	1
	Gravel, fine to medium, very sandy, unsorted, abundant carbonate, oxi- dized-----	2	3
	Till, dark-yellowish-orange, cal- careous, oxidized-----	11	14
	Gravel, fine to coarse, sandy, un- sorted, angular to rounded, fossil shell fragments, oxidized; minor layers of silt, lignitic-----	6	20
Tongue River Formation:			
	Sand, very fine to medium, subangular, sorted, lignite fragments-----	11	31
	Sand, very fine to medium, subangular, sorted, predominately quartz with black and green grains-----	10	41

TABLE 2.--Logs of test holes -- Continued

142-79-26ddd, Continued
Test hole 2005

<u>Formation</u>	<u>Material</u>	<u>Thickness</u> (feet)	<u>Depth</u> (feet)
Cannonball Formation:			
	Clay, olive-gray, cohesive, silty----	4	45

142-80-2abb
City of Wilton Test well 1
Log by C. A. Simpson and Son

<u>Material</u>	<u>Thickness</u> (feet)	<u>Depth</u> (feet)
Topsoil-----	1	1
Brown clay and rock-----	6	7
Yellow clay-----	20	27
Blue clay-----	25	52
Hardpan and rock-----	5	57
Slightly gravelly clay-----	23	80
Sandy clay-----	22	102
Coal-----	5	107
Sandy gray clay-----	1	108
Fine loose sand-----	5	113
Soft gray clay-----	29	142
Coal and brown clay-----	3	145
Blue shale-----	17	162
Coal-----	1	163
Gray shale-----	40	203
Dark shale with little coal-----	17	220

Remarks: About the only water was that from the 107-113 ft. layer. Water level was 60 feet from the surface.

TABLE 2.--Logs of test holes -- Continued

142-80-3aaa
Test hole 1985

<u>Formation</u>	<u>Material</u>	<u>Thickness</u> (feet)	<u>Depth</u> (feet)
Glacial drift:			
	Till, moderate-yellowish-brown, lignite fragments, highly-calcareous, oxidized-----	7	7
Tongue River Formation:			
	Clay, moderate-yellowish-brown, silty, cohesive, oxidized-----	4	11
	Clay, dusky-yellow, silty, cohesive, calcareous-----	7	18
	Clay, dusky-yellowish-brown, silty, cohesive, oxidized-----	4	22
	Lignite, hard, sharp fragments-----	4	26
	Clay, medium-bluish-gray, silty, indurated, lignite smears-----	11	37
	Sand, medium-bluish-gray, very fine, silty, lignite and mica flakes-----	14	51
	Clay, medium-bluish-gray, silty, cohesive, lignite flecks, highly-calcareous-----	8	59
	Lignite, hard-----	3	62
	Clay, light-bluish-gray, silty, minor lignite flecks-----	3	65
	Lignite, hard-----	1/2	65 1/2
	Clay, pale-blue-green, slightly-silty-----	7 1/2	73
	Clay, light-olive-gray, silty, cohesive, highly-calcareous-----	2	75
	Silt, brownish-black, cohesive, abundant lignite fragments, highly-calcareous-----	6	81
	Clay, dark-greenish-gray, silty, indurated, calcareous-----	16	97
	Clay, greenish-gray, silty, indurated, white calcareous layers-----	9	106
	Lignite-----	1	107
	Silt, light-olive-gray, clayey, lignite flecks, calcareous-----	11	118
	Sandstone, olive-gray, very hard, indurated, calcareous-----	1	119

TABLE 2.--Logs of test holes -- Continued

142-80-3aaa, Continued
 Test hole 1985

<u>Formation</u>	<u>Material</u>	<u>Thickness</u> (feet)	<u>Depth</u> (feet)
Tongue River Formation-Continued:			
	Silt, olive-gray, clayey, very fossiliferous, calcareous-----	19	138
	Lignite-----	1	139
	Silt, olive-black; sand, very fine--	6	145
	Silt, grayish-blue-green, clayey, occasional lignite chips-----	7	152
	Sand, very fine, clayey, calcareous-	4	156
	Clay, light-olive-gray, silty, lignite fragments, calcareous-----	7	163
	Lignite-----	1	164
	Sand, light-olive-gray, lignitic----	58	222

Cannonball Formation:

	Silt, olive-gray to olive-black, very clayey-----	3	225
--	---	---	-----

142-81-4adc
 Test hole 1984

<u>Formation</u>	<u>Material</u>	<u>Thickness</u> (feet)	<u>Depth</u> (feet)
Glacial drift:			
	Clay, yellowish-orange, sandy, oxidized-----	4	4
	Gravel, fine to medium, sandy, oxidized-----	3	7
Cannonball Formation:			
	Sand, very fine to fine, silty to clayey, lignite fragments, oxidized-----	33	40
	Sand, fine, silty to clayey, lignite fragments-----	13	53
	Sandstone, friable, highly-calcareous-----	5	58

TABLE 2.--Logs of test holes -- Continued

142-81-4adc, Continued
Test hole 1984

<u>Formation</u>	<u>Material</u>	<u>Thickness</u> (feet)	<u>Depth</u> (feet)
Cannonball Formation:			
	Sand, fine, silty to clayey, unsorted, abundant lignite and mica, (glauconitic)-----	5	63
	Sand, greenish-black, silty, (glauconitic)-----	25	88
	Silt, olive-gray, sandy, lignite and mica flakes, slightly-calcareous---	1	89
	Limestone, olive-gray, sandy-----	2	91
	Silt, olive-gray, clayey to sandy, harder than above, slightly-calcareous-----	26	117
	Sand, olive-gray, abundant lignite and green specks (glauconitic)-----	2	119
	Limestone, sandy, very hard-----	4	123
	Silt, olive-gray, sandy, mica flakes-----	13	136
	Sand, grayish-blue-green, very fine to fine, (abundant glauconite)-----	9	145
Hell Creek Formation:			
	Sand, olive-gray, very silty, lignite and mica flakes-----	17	162
	Silt, olive-black, clayey, lignite and mica flakes-----	8	170
	Silt, olive-black, pyrites-----	18	188
	Silt, light-olive-gray, pyrite, mica, and lignite-----	9	197
	Sand, grayish-blue-green, very fine to medium, angular, abundant green grains (glauconitic)-----	12	209
	Silt, olive-gray, sandy-----	6	215
	Sand, light-olive-gray, very fine to medium, green grains, (glauconitic)	19	234

TABLE 2.--Logs of test holes -- Continued

142-81-4adc, Continued
 Test hole 1984

<u>Formation</u>	<u>Material</u>	<u>Thickness</u> (feet)	<u>Depth</u> (feet)
Hell Creek Formation-Continued:			
	Silt, greenish-gray, sandy to clayey, lignitic-----	16	250
	Sand, olive-black, very fine to fine, abundant green grains (glauconite)-	13	263
	Sand, clayey, mostly quartz, some mica and greenish grains-----	5	268
	Limestone, sandy-----	3	271
	Sand, olive-gray, very fine to medium, clayey-----	16	287
	Silt, dark-greenish-gray; sand, very fine; mica and lignite flakes, a- bundant light-bluish to greenish grains-----	47	334
	Sand, very fine to fine, silty, black and green grains-----	14	348
	Lignite-----	5	353
	Clay, olive-gray, silty-----	11	364
Fox Hills Sandstone:			
	Clay, greenish-gray, silty to sandy, (glauconitic)-----	16	380
	Sand, greenish-gray, fine to medium, abundant green and black grains (glauconitic)-----	15	395
	Sand, greenish-gray, fine to medium clayey, (glauconitic)-----	5	400
	Sand, greenish-gray, fine to medium, clayey (glauconitic)-----	35	435

TABLE 2.--Logs of test holes -- Continued

143-75-16acc
U. S. B. R. drill hole 41

<u>Material</u>	<u>Thickness</u> (feet)	<u>Depth</u> (feet)
Clay, brown, wet, sandy-----	3.1	3.1
Gravel, brown, dry, silty, sandy-----	3.5	6.6
Clay (glacial till), brown, wet, color changing to gray at 7.5', sandy, silty, gravels through- out, occasional cobbles and boulders, moderately plastic, soft-----	21.5	28.1
Sand, dark-gray, moist, very fine, clayey-----	11.9	40

143-75-16bdd
U. S. B. R. drill hole 40

<u>Material</u>	<u>Thickness</u> (feet)	<u>Depth</u> (feet)
Clay, brown, moist, sandy-----	2.8	2.8
Clay (glacial till), brown, dry, color changing to gray and be- coming moist to wet at 7.3', silty, sandy, soft, moderately plastic, occasional cobble and boulder, gravels throughout-----	23.7	26.5
Sand, dark-gray, moist, clayey, poorly-graded, fine-----	18.5	45

TABLE 2.--Logs of test holes -- Continued

143-75-17aac
U.S.B.R. drill hole 39

<u>Material</u>	<u>Thickness</u> (feet)	<u>Depth</u> (feet)
Clay (glacial till), brown, wet, soft, color changing to gray at 7.5', silty, sandy, moderately plastic, occasional cobble and boulder, gravels through-----	18.2	18.2
Shale, (Fort Union Group), black, wet, sandy, lignite stained-----	5.6	23.8
Sandstone, gray, dirty, hard, dry----	0.4	24.2
Shale (Fort Union Group), black, sandy, wet-----	2.8	27
Sandstone, gray, dirty, hard, wet----	0.5	27.5
Shale, (Fort Union Group), black, sandy, wet, lignite stained-----	2.5	30

143-75-19daa
Test hole 2056

<u>Formation</u>	<u>Material</u>	<u>Thickness</u> (feet)	<u>Depth</u> (feet)
Glacial drift:			
	Silt and clay, moderate-olive-brown, sandy, lacustrine-----	11	11
	Sand, very coarse; gravel, fine to medium-----	2	13
	Till, light-olive-gray, sandy, calcareous, oxidized-----	7	20
	Till, olive-gray to medium-gray, sandy to gravelly, calcareous-----	10	30
	Till, medium-dark-gray; sandy to gravelly, calcareous-----	27	57
	Sand, coarse to very coarse, gravelly, abundant limestone particles-----	1	58
	Till, medium-dark-gray, sandy to gravelly, calcareous-----	17	75
	Sand, gravel, clay, reworked bed-rock, angular fragments-----	6	81

TABLE 2.--Logs of test holes -- Continued

143-75-19daa, Continued
Test hole 2056

<u>Formation</u>	<u>Material</u>	<u>Thickness</u> (feet)	<u>Depth</u> (feet)
Cannonball Formation:			
	Shale, olive-gray, soft, silty-----	9	90
	Sandstone, olive-black, friable, poorly-sorted, blue-green grains-----	10	100
	Siltstone, olive-black to olive- gray, few blue-green grains-----	5	105

143-75-24dad
U.S.B.R. drill hole 42

<u>Material</u>	<u>Thickness</u> (feet)	<u>Depth</u> (feet)
Clay (glacial till), brown, wet, color changing to gray at 11.8', sandy, silty, stiff, gravels throughout; moderately plastic, occasional cobbles and boulders-----	60	60

143-76-7baa
Test hole 1991

<u>Formation</u>	<u>Material</u>	<u>Thickness</u> (feet)	<u>Depth</u> (feet)
Glacial drift:			
	Topsoil-----	1	1
	Sand, medium to very coarse, well- sorted, subrounded to well- rounded-----	7	8
	Sand, medium to very coarse, gravelly, unsorted, subrounded, abundant limestone-----	9	17

TABLE 2.--Logs of test holes -- Continued

143-76-7baa, Continued
 Test hole 1991

<u>Formation</u>	<u>Material</u>	<u>Thickness</u> (feet)	<u>Depth</u> (feet)
Glacial drift-Continued:			
	Sand, medium to very coarse; gravel, medium; unsorted, subrounded-----	6	23
	Sand, fine to coarse, well-sorted, subrounded to well-rounded, abundant shale-----	7	30
Cannonball Formation:			
	Clay, olive-gray, silty-----	45	75

143-76-12da
 U.S.B.R. drill hole 38

<u>Material</u>	<u>Thickness</u> (feet)	<u>Depth</u> (feet)
Silt, black, organic, wet topsoil----	1	1
Silt, gray and brown, moist-----	6.2	7.2
Clay (glacial till), moist, stiff, brown, becoming wet and changing color to gray at 12.7', sandy, silty, occasional cobbles and boulders, moderately plastic-----	32.8	40

143-78-7cbb
 Auger hole 26

<u>Formation</u>	<u>Material</u>	<u>Thickness</u> (feet)	<u>Depth</u> (feet)
Glacial drift:			
	Topsoil, dusky-brown, clayey-----	2	2
	Till, moderate-yellowish-brown, sandy, shale pebbles-----	42	44

TABLE 2.--Logs of test holes -- Continued

143-78-7cbb, Continued
Auger hole 26

<u>Formation</u>	<u>Material</u>	<u>Thickness</u> (feet)	<u>Depth</u> (feet)
Tongue River Formation:			
	Clay, dusky-brown, silty, carbon- aceous, tough-----	8	52

143-78-18bbb
Auger hole 20

<u>Formation</u>	<u>Material</u>	<u>Thickness</u> (feet)	<u>Depth</u> (feet)
Glacial drift:			
	Topsoil, dusky-brown, sandy-----	2	2
	Till, moderate-yellowish-brown, sandy, oxidized, calcareous-----	23	25

143-78-35ccc
Test hole 1990

<u>Formation</u>	<u>Material</u>	<u>Thickness</u> (feet)	<u>Depth</u> (feet)
Glacial drift:			
	Topsoil-----	2	2
	Till, moderate-yellowish-brown, silty to sandy, highly-calcareous, oxi- dized-----	30	32
Tongue River Formation:			
	Silt, light-olive-gray, clayey, lig- nitic-----	3	35
	Clay, dark-yellowish-orange, silty, oxidized-----	1	36
	Silt, dusky-yellow, clayey, lignite flecks, oxidized-----	4	40

TABLE 2.--Logs of test holes -- Continued

143-78-35ccc, Continued
Test hole 1990

<u>Formation</u>	<u>Material</u>	<u>Thickness</u> (feet)	<u>Depth</u> (feet)
Tongue River Formation-Continued:			
	Lignite, soft, (saturated)-----	1	41
	Clay, dark-gray, silty, lignite-----	2	43
	Lignite, soft-----	1	44
	Clay, dark- gray, silty-----	3	47
	Sand, very fine to coarse, subrounded to well-rounded, lignite-----	13	60
	Sand, very fine to medium, clayey, abundant mica and lignite flecks, and green grains (glacuonitic)-----	40	100

Cannonball Formation:

	Silt, brownish-black, clayey, lig- nite fragments-----	3	103
	Sandstone, very fine to fine-grained, mica flakes, calcareous-----	16	119
	Silt, olive-gray, clayey, cohesive; sand, fine; mica and lignite fragments-----	16	135

143-79-10baa
Auger hole 19

<u>Formation</u>	<u>Material</u>	<u>Thickness</u> (feet)	<u>Depth</u> (feet)
Glacial drift:			
	Topsoil, dusky-brown, clayey-----	2	2
	Till, moderate-yellowish-brown, sandy, shale pebbles, oxidized-----	31	33
	Till, light-olive-gray, sandy, shale pebbles-----	25	58
	Sand, fine to coarse, lignite frag- ments-----	21	79

TABLE 2.--Logs of test holes -- Continued

143-79-10baa, Continued
Auger hole 19

<u>Formation</u>	<u>Material</u>	<u>Thickness</u> (feet)	<u>Depth</u> (feet)
Tongue River Formation:			
	Clay, grayish-green; sand, fine to medium-----	10	89
	Sandstone, grayish-green, fine grain-ed-----	1/2	89 1/2

143-79-11aad
Auger hole 25

<u>Formation</u>	<u>Material</u>	<u>Thickness</u> (feet)	<u>Depth</u> (feet)
Glacial drift:			
	Clay, moderate-yellowish-brown, silty, occasional pebbles-----	31	31
	Clay, grayish-brown, silty-----	8	39
	Clay, light-olive-gray, silty-----	6	45
	Sand, gray, fine to medium-----	1	46
Tongue River Formation:			
	Shale, dusky-brown, carbonaceous-----	6	52

143-79-14dad
Auger hole 27

<u>Formation</u>	<u>Material</u>	<u>Thickness</u> (feet)	<u>Depth</u> (feet)
Glacial drift:			
	Topsoil, dusky- brown, silty-----	2	2
	Clay, moderate-yellowish-brown; sand, fine to very coarse-----	12	14
	Clay, light-olive-gray; sand, fine to very coarse-----	7	21

TABLE 2.--Logs of test holes -- Continued

143-79-14dad, Continued
Auger hole 27

<u>Formation</u>	<u>Material</u>	<u>Thickness</u> (feet)	<u>Depth</u> (feet)
Glacial drift-Continued:			
	Gravel, fine to coarse; sand, fine to very coarse-----	36	57
	Clay, light-olive-gray; sand, fine; interbedded-----	22	79
	Clay, light-olive-gray; sand, fine; interbedded-----	22	79
	Clay, light-olive-gray, silty-----	6	95

Cannonball Formation:

	Sand, greenish-gray, fine to medium---	2	97
--	--	---	----

143-80-35daa2
City of Wilton test well 2
Log by C. A. Simpson and son

<u>Material</u>	<u>Thickness</u> (feet)	<u>Depth</u> (feet)
Topsoil-----	1	1
Yellow clay-----	29	30
Firm sandy yellow clay-----	46	76
Fine clayey sand with water-----	8	84
Sand and coal-----	4	88
Gray clay or shale with traces of coal-----	40	128
Dark gray shale, rather tough-----	20	148
Light gray shale-----	6	154
Light gray shale with a trace of coal-----	10	164

Remarks: The principal source of water is from 68-88 feet. Water level was 62 feet from the surface.

TABLE 2.--Logs of test holes -- Continued

143-80-36cbb2
 City of Wilton test well 3
 Log by C. A. Simpson and son

<u>Material</u>	<u>Thickness</u> (feet)	<u>Depth</u> (feet)
Topsoil-----	1	1
Yellow clay and large boulder-----	3	4
Dark clay and rocks-----	8	12
Gray and slightly sandy gray clay-----	22	34
Sandy yellow clay (apparently water-bearing when below the water level)--	36	70
Consolidated clayey yellow sand-----	23	93
Yellow clay-----	5	98
Dark clay-----	6	104

Remarks: Water-bearing formation from 70-93 feet.
 Water level 64 feet below the surface.

144-75-15aaa
 Test hole 1993

<u>Formation</u>	<u>Material</u>	<u>Thickness</u> (feet)	<u>Depth</u> (feet)
Glacial drift:			
	Till, dusky-yellow, silty to gravelly, lignite fragments, highly-calcareous-	15	15
	Till, dark-greenish-gray, silty to gravelly, abundant shale grains, some lignite fragments, calcareous---	91	106
	Till, dark-greenish-gray, very gravelly-----	4	110
Cannonball Formation:			
	Silt, olive-gray, very sandy to clayey, rounded (glaucopitetic)-----	2	112
	Sandstone, fine-grained, abundant angular grains-----		112

TABLE 2.--Logs of test holes -- Continued

144-76-7dad
Test hole 2052

<u>Formation</u>	<u>Material</u>	<u>Thickness</u> (feet)	<u>Depth</u> (feet)
Glacial drift:			
	Gravel, fine to very coarse, sandy, cobbles, unsorted, subangular to rounded-----	15	15
	Till, moderate-yellowish-brown, calcareous-----	3	18
	Till, dark-greenish-gray, abundant shale, limestone, and lignite fragments, calcareous-----	40	58
	Gravel, fine to coarse, very sandy, unsorted, rounded, abundant lignite-----	43	101
	Till, dark-greenish-gray, abundant shale, limestone, and lignite fragments, calcareous-----	34	135
Cannonball Formation:			
	Clay, moderate-yellowish-brown, silty, indurated, mica flecks, oxidized----	1	136
	Clay, light-olive-gray, silty to sandy, indurated, mica flakes-----	9	145
	Clay, olive-gray, very silty, indurated, mica flakes, lignite seams, calcareous-----	5	150

144-76-12bbb
Test hole 2044

<u>Formation</u>	<u>Material</u>	<u>Thickness</u> (feet)	<u>Depth</u> (feet)
Glacial drift:			
	Gravel, brown, medium; sand, very coarse, rounded, some lignite particles-----	31	31
	Till, olive-gray, sandy, cohesive, calcareous-----	4	35

TABLE 2.--Logs of test holes -- Continued

144-76-12bbb, Continued
Test hole 2044

<u>Formation</u>	<u>Material</u>	<u>Thickness</u> (feet)	<u>Depth</u> (feet)
Glacial drift-Continued:			
	Gravel, medium to coarse, sandy-----	8	43
	Till, olive-gray, calcareous, inter- bedded gravel layers, lignite frag- ments-----	17	60
	Till, olive-gray, sandy, oxidized, calcareous-----	92	152
	Gravel, medium-----	4	156
	Till, light-olive-gray, sandy, cal- careous-----	8	164
	Gravel, medium, angular, mostly reworked bedrock, oxidized-----	1	165
Cannonball Formation:			
	Shale, olive-black, silty; siltstone, sandy, soft, bluish-green grains-----	15	180

144-76-29aaa
Test hole 1992

<u>Formation</u>	<u>Material</u>	<u>Thickness</u> (feet)	<u>Depth</u> (feet)
Glacial drift:			
	Sand, fine to very coarse, gravelly, unsorted, angular to rounded, lig- nite fragments-----	34	34
	Gravel, medium to coarse-----	3	37
	Till, dark-greenish-gray, lignite fragments, calcareous-----	20	57
	Sand, very fine to coarse, clayey, unsorted, angular to rounded-----	10	67
Cannonball Formation:			
	Silt, dark-greenish-gray, cohesive, lignite and mica flakes-----	8	75

TABLE 2.--Logs of test holes -- Continued

144-76-31bcd
U.S.B.R. drill hole 36

<u>Material</u>	<u>Thickness</u> (feet)	<u>Depth</u> (feet)
Sand, brown, dry, silty, with few gravels-----	6.8	6.8
Sand, brown, moist, fine to medium, silty, color changes to gray at 18.8'-----	18.2	25

144-76-31dbb
U.S.B.R. drill hole 37

<u>Material</u>	<u>Thickness</u> (feet)	<u>Depth</u> (feet)
Gravel, brown, wet, poorly graded, lacks coarse and fine sizes, silty-----	12.2	12.2
Sand, brown, wet, medium to coarse, few small gravels-----	5.8	18
Sand, gray, wet, fine to medium, small gravel seams and lignite particles---	17	35

144-77-8aab
Auger hole 23

<u>Formation</u>	<u>Material</u>	<u>Thickness</u> (feet)	<u>Depth</u> (feet)
Glacial drift:			
	Till, moderate-yellowish-brown, shale pebbles, oxidized, calcareous-----	32	32
Cannonball Formation:			
	Clay, moderate-brown; sand, fine to medium, rounded, silty-----	53	85
	Clay, light-olive-gray; sand, fine; interbedded-----	2	87
	Sand, light-olive-gray, fine to medium, lignitic-----	25	112

TABLE 2.--Logs of test holes -- Continued

144-77-18daa
Test hole 1988

<u>Formation</u>	<u>Material</u>	<u>Thickness</u> (feet)	<u>Depth</u> (feet)
Glacial drift:			
	Silt, moderate-yellowish-brown; sand, fine, highly-calcareous, oxidized-----	8	8
	Sand, fine to very coarse, gravelly, unsorted, angular to subrounded, partially-oxidized-----	4	12
	Till, dark-greenish-gray, lignite fragments, calcareous-----	1	13
	Sand, medium to very coarse; gravel, granule; poorly-sorted, subrounded to rounded-----	9	22
	Till, dark-greenish-gray, calcareous--	20	42
Cannonball Formation:			
	Silt, light-olive-gray, mica and lignite fragments-----	18	60

144-77-23cac
Test hole 2043

<u>Formation</u>	<u>Material</u>	<u>Thickness</u> (feet)	<u>Depth</u> (feet)
Glacial drift:			
	Sand, very fine to very coarse, clayey, unsorted-----	7	7
	Till, light-olive-gray, very silty, calcareous-----	4	11
	Gravel, medium-----	1	12
	Till, moderate-yellowish-brown, lig- nite fragments, calcareous-----	11	23
	Till, dark-greenish-gray, very silty, lignite fragments, calcareous-----	41	64
	Gravel, fine to coarse, sandy, un- sorted, rounded-----	11	75

TABLE 2.--Logs of test holes -- Continued

144-77-23cac, Continued
Test hole 2043

<u>Formation</u>	<u>Material</u>	<u>Thickness</u> (feet)	<u>Depth</u> (feet)
Glacial drift-Continued:			
	Till, dark-greenish-gray, very silty, lignite fragments, calcareous-----	7	82
	Clay, dark-greenish-gray, calcareous, hard-----	11	93
	Silt, dark-greenish-gray, cohesive, tiny lignite flecks, calcareous----	8	101
	Till, dark-greenish-gray, very silty, lignite fragments, calcareous-----	15	116
	Sand, very fine to coarse, gravelly, unsorted-----	1 1/2	117 1/2
	Till, dark-greenish-gray, silty, shale pebbles, lignite fragments, calcareous-----	16 1/2	134
	Till, dark-yellowish-orange, silty to sandy, oxidized, lignite fragments-----	15	149
Cannonball Formation:			
	Silt, dusky-yellow, sandy, indurated, some lignite-----	26	175
	Sand, moderate-olive-brown, very fine to fine, clayey, slightly-oxidized-	4	179
	Sand, dark-greenish-gray, very fine to fine, glauconitic, silty-----	1	180

144-77-36acb
U.S.B.R. drill hole 35

<u>Material</u>	<u>Thickness</u> (feet)	<u>Depth</u> (feet)
Clay, black, wet, plastic, organic---	3.2	3.2
Clay (glacial till), brown, stiff, wet, silty, sandy, gravels, throughout, occasional cobbles and boulders, moderately plastic, color changes to gray at 16.8'-----	24	27.2

TABLE 2.--Logs of test holes -- Continued

144-77-36acb, Continued
U.S.B.R. drill hole 33

<u>Material</u>	<u>Thickness</u> (feet)	<u>Depth</u> (feet)
Sand, gray, wet, silty, with few gravels, dense-----	7.8	35

144-77-36bac
U.S.B.R. drill hole 34

<u>Material</u>	<u>Thickness</u> (feet)	<u>Depth</u> (feet)
Clay (glacial till), brown, moist, stiff, silty, sandy, cobbles and boulders, gravels throughout, moderately plastic-----	12.8	12.8
Clay (glacial till), same as above but gray-----	9.7	22.5
Sand, gray, fine, silty, moist-----	4.6	27.1
Gravel, medium to fine, brown, sandy, many shale particles-----	2.9	30

144-77-36bbd
U.S.B.R. drill hole 33

<u>Material</u>	<u>Thickness</u> (feet)	<u>Depth</u> (feet)
Topsoil, silty sand, tan-----	1.5	1.5
Clay, brown, moist, highly alkaline--	2.1	3.6
Clay (glacial till), brown, moist, stiff, moderately plastic, sandy, silty, occasional cobbles and boulders, gravels throughout, color changes to gray at 16.2', occasional sand seams 16.2' to 40'-----	36.4	40

TABLE 2.--Logs of test holes -- Continued

144-78-3cdd
Test hole 1987

<u>Formation</u>	<u>Material</u>	<u>Thickness</u> (feet)	<u>Depth</u> (feet)
Glacial drift:			
	Road fill.....	7	7
	Silt, dark-greenish-gray, very fossiliferous, highly-calcareous.....	10	17
	Sand, medium to very coarse, gravelly, poorly-sorted, subrounded to rounded.....	7	24

Cannonball Formation:

	Clay, olive-gray, very silty, indurated.....	16	40
--	--	----	----

144-78-14ccc
U.S.B.R. drill hole 28

<u>Material</u>	<u>Thickness</u> (feet)	<u>Depth</u> (feet)
Topsoil, sandy silt, tan, organic.....	0.6	0.6
Gravel, brown, moist, sandy and silty, gravel, medium to coarse.....	24.4	25

144-78-14cdc
U.S.B.R. drill hole 29

<u>Material</u>	<u>Thickness</u> (feet)	<u>Depth</u> (feet)
Topsoil, dark-brown, organic silty clay.....	1	1
Silt, brown frozen.....	2.2	3.2
Gravel, brown, medium.....	8.1	11.3
Silty sand, gray, fine silty, sand, low density.....	4.2	15.5
Silt, gray, stiff.....	8	23.5
Clay (glacial till), brown, silty, sandy, gravels throughout, occasional cobbles and boulders, stiff, moderately plastic.....	6.5	30

TABLE 2.--Logs of test holes -- Continued

144-78-15ddd
U.S.B.R. drill hole 27a

<u>Material</u>	<u>Thickness</u> (feet)	<u>Depth</u> (feet)
Silt, black, moist, sandy, organic----	1.8	1.8
Gravel, brown, moist, medium to coarse, sandy-----	14.8	16.6
Gravel, brown, moist, coarse, clayey--	1.6	18.2
Shale (Tongue River Formation), gray, moist, sandy-----	6.8	25

144-78-21aaa
Auger hole 24

<u>Formation</u>	<u>Material</u>	<u>Thickness</u> (feet)	<u>Depth</u> (feet)
Glacial drift:			
	Till, moderate-yellowish-brown, sandy, shale pebbles, oxidized, calcareous--	28	28
	Till, light-olive-gray, shale pebbles, calcareous-----	44	72
Cannonball Formation:			
	Clay, greenish-gray; sand, fine to medium-----	8	80

144-78-23aa
U.S.B.R. drill hole 31

<u>Material</u>	<u>Thickness</u> (feet)	<u>Depth</u> (feet)
Topsoil, sandy, silt, tan, organic----	1	1
Clay (glacial till), brown, sandy, silty, gravels throughout, oc- casional cobbles and boulders, moist, stiff-----	6.8	7.8
Silty sand, gray, wet, fine to med- ium-----	5.4	13.2

TABLE 2.--Logs of test holes -- Continued

144-78-23aa, Continued
U.S.B.R. drill hole 31

<u>Material</u>	<u>Thickness</u> (feet)	<u>Depth</u> (feet)
Silt, gray, wet, small sand seams	13.5	26.7
Shale (Tongue River Formation), a light-blue, moist, hard, silty, clay shale	3.3	30

144-78-23abb
U.S.B.R. drill hole 30

<u>Material</u>	<u>Thickness</u> (feet)	<u>Depth</u> (feet)
Topsoil, dark-brown, organic silty sand	1.6	1.6
Sand and gravel, brown and gray, med- ium to coarse sand, fine to medium gravel, saturated below 7.5' (Pene- tration test 14'-20' indicates loose condition)	31.8	33.4
Clay (glacial till) brown, very stiff silty, sandy, gravels throughout, occasional cobbles and boulders, medium plasticity	6.6	40

144-78-26cdc
Test hole 1989

<u>Formation</u>	<u>Material</u>	<u>Thickness</u> (feet)	<u>Depth</u> (feet)
Glacial drift:			
	Topsoil, black, silty	1	1
	Sand, fine to very coarse, gravelly, unsorted, subangular to rounded	12	13
	Gravel, fine, sandy, unsorted, rounded, lignite fragments	13	26

TABLE 2.--Logs of test holes -- Continued

144-78-26cdc, Continued
Test hole 1989

<u>Formation</u>	<u>Material</u>	<u>Thickness</u> (feet)	<u>Depth</u> (feet)
Cannonball Formation:			
	Shale, olive-gray, silty, lignite fragments-----	4	30

144-79-1ccb
Test hole 2051

<u>Formation</u>	<u>Material</u>	<u>Thickness</u> (feet)	<u>Depth</u> (feet)
Glacial drift:			
	Sand, very fine to very coarse, clayey, unsorted, subrounded, cal- careous, oxidized-----	13	13
	Sand and clay, dark-greenish-gray, calcareous, unoxidized-----	10	23
	Till, olive-gray, abundant shale, limestone and lignite fragments, calcareous-----	8	31
	Sand, unsorted, rounded; gravel, fine-----	4	35
Cannonball Formation:			
	Clay, olive-gray, silty, indurated, abundant lignite fragments-----	25	60

TABLE 2.--Logs of test hole -- Continued

144-79-25bcc
Test hole 1986

<u>Formation</u>	<u>Material</u>	<u>Thickness</u> (feet)	<u>Depth</u> (feet)
Glacial drift:			
	Topsoil-----	2	2
	Till, yellowish to light-olive-gray, highly-calcareous-----	4	6
	Gravel, fine to medium, sandy, sub- rounded to rounded, unsorted-----	17	23
	Clay, dark-greenish-gray, very silty, cohesive, calcareous-----	43	66

Cannonball Formation:

	Shale, greenish-black, silty, dark- greenish-gray, abundant lignite-----	9	75
--	---	---	----

144-79-29ccb
Test hole 2050

<u>Formation</u>	<u>Material</u>	<u>Thickness</u> (feet)	<u>Depth</u> (feet)
Glacial drift:			
	Till, light-olive-gray, silty to sandy-----	5	5
	Gravel, stained black, fine to coarse, unsorted-----	5	10
	Gravel, fine to coarse, sandy, un- sorted-----	10	20

Cannonball Formation:

	Silt, greenish-gray, mica and lignite flakes, slightly-calcareous-----	10	30
--	---	----	----

TABLE 4.--Chemical analyses of ground water from Quaternary aquifers showing trace or minor constituents

Location	Depth	Date of collection	Results in parts per million							
			Iron			Manganese (Mn)	Copper (Cu)	Zinc (Zn)	Nitrite (NO ₂)	Orthophosphate (PO ₄)
			Ferrous (Fe)	Ferric (Fe)	Total (Fe)					
137-78-8bcb	216	7-18-62	2.1	.84
137-78-33aba	185	8-6-6227	.84
137-79-26cbb	86	8-6-6286	.00
138-76-33bbb	110	8-6-6217	1.6
138-77-15aaa	210	8-6-62	2.3	.05
138-77-15dcb	138.4	9-8-61 a/	1.9	2.5	4.4	.39	.10	4.1	.03	.05
138-77-25bbd1	78.2	9-9-61 a/	.53	.64	1.2	.60	.34	.00	.00	.27
138-78-27ccd	210	8-3-6226	.48
138-78-32daa	185	8-3-6258	.43
138-80-9bcd	105	9-8-61 a/	4.5	6.1	11	.44	.06	.34	.01	.04
138-80-15bbd	129	9-7-61 a/	3.8	3.6	7.4	.16	.13	.23	.05	.04
138-80-15cba	164	9-7-61 a/	3.2	3.6	6.8	.07	.10	.98	.04	.36
138-80-17acb1	190	9-8-61 a/	3.7	4.6	8.3	.35	.17	.34	.08	.09
138-80-22aac	131	9-8-61 a/	1.9	2.9	4.8	.09	.05	.66	.01	.18
138-80-23bdc	110	9-8-61 a/	1.7	2.2	3.9	.09	.05	.44	.01	.26
138-80-24cac1	80	9-9-61 a/	.02	.36	.38	.00	.03	.04	.02	.27
139-78-27cbb	225	8-3-6236	.01
139-81-11adc	104	9-8-61 a/	4.3	4.9	9.2	.59	.11	1.6	.01	.10
140-75-12cdd	167	8-2-6211	1.3
140-76-25ccc	70	8-6-6229	1.4
140-78-36bba	86	7-8-6284	.00
140-81-5aaa	90	8-62	1.6	.14

a/ Selenium (Se) 0.00, and Sulfide (S) 0.0.

TABLE 5.--Water-level measurements in selected wells
in Burleigh County, North Dakota

137-76-32bbb
Paul McCay, stock well

<u>Date</u>	<u>Water level</u>	<u>Date</u>	<u>Water level</u>	<u>Date</u>	<u>Water level</u>
Sept. 13, 1960	98.11	Mar. 8, 1963	97.18	Sept. 6, 1963	96.54
Sept. 11, 1962	97.50	Apr. 17,	97.17	Oct. 2.	99.51
Dec. 10,	98.89	May 7,	99.04b	Nov. 1,	96.59
Jan. 3, 1963	97.08	June 24,	97.45		
Feb. 7,	96.90	Aug. 9,	100.25b		

b= well pumped recently

137-78-8bcb
Test hole 2014

<u>Date</u>	<u>Water level</u>	<u>Date</u>	<u>Water level</u>	<u>Date</u>	<u>Water level</u>
Aug. 16, 1962	47.41	Jan. 3, 1963	47.70	Aug. 9, 1963	47.60
31,	47.53	Feb. 7,	47.58	Sept. 6,	47.76
Sept. 11,	47.52	Mar. 8,	47.48	Oct. 2,	47.73
Oct. 3,	47.65	Apr. 16,	47.38	Nov. 1,	47.95
26,	47.69	May 7,	47.40	Dec. 3,	47.97
Dec. 10,	47.73	June 24	47.48	Jan. 2, 1964	47.93

TABLE 5.--Water-level measurements in selected wells
in Burleigh County, North Dakota -- Continued

137-78-33aba
Test hole 2039

<u>Date</u>	<u>Water level</u>	<u>Date</u>	<u>Water level</u>	<u>Date</u>	<u>Water level</u>
Aug. 16, 1962	66.35	Jan. 3, 1963	66.46	Aug. 9, 1963	66.61
31,	66.51	Feb. 7,	66.26	Sept. 6,	66.71
Sept. 11,	66.50	Mar. 8,	66.08	Oct. 2,	66.81
Oct. 3,	66.64	Apr. 16,	66.15	Nov. 1,	66.91
26,	66.61	May 7,	65.93	Dec. 3,	66.84
Dec. 10,	66.59	June 24,	66.23	Jan. 2, 1964	66.58

137-79-26cbb
Test hole 2015

<u>Date</u>	<u>Water level</u>	<u>Date</u>	<u>Water level</u>	<u>Date</u>	<u>Water level</u>
Aug. 16, 1962	13.24	Jan. 3, 1963	13.17	Aug. 9, 1963	12.96
31,	13.70	Feb. 7,	12.19	Sept. 6,	13.67
Sept. 11	13.97	Mar. 8,	11.63	Oct. 2,	13.91
Oct. 3,	14.19	Apr. 16,	12.15	Nov. 1,	13.60
26,	14.23	May 7,	12.24	Dec. 3,	13.02
Dec. 10,	14.04	June 24,	12.41	Jan. 2, 1964	11.90

TABLE 5.--Water-level measurements in selected wells
in Burleigh County, North Dakota -- Continued

138-76-33bbb
Test hole 2022

<u>Date</u>	<u>Water level</u>	<u>Date</u>	<u>Water level</u>	<u>Date</u>	<u>Water level</u>
Aug. 16, 1962	5.72	Jan. 3, 1963	5.98	Aug. 9, 1963	6.19
29,	5.99	Feb. 7,	5.85	Sept. 6,	6.52
Sept. 11,	6.12	Mar. 8,	5.74	Oct. 2,	6.98
Oct. 4,	6.30	Apr. 17,	5.61	Nov. 1,	6.88
26,	6.22	May 7,	5.59	Dec. 3,	6.96
Dec. 10,	6.11	June 24,	5.73	Jan. 2, 1964	6.79

138-77-15aaa
Test hole 2023

<u>Date</u>	<u>Water level</u>	<u>Date</u>	<u>Water level</u>	<u>Date</u>	<u>Water level</u>
Aug. 14, 1962	14.33	Oct. 10, 1962	12.93	Jan. 1, 1963	11.56
16,	14.96	16,	12.79	Feb. 7,	11.20
23,	14.64	21,	12.63	Mar. 8,	11.02
28,	15.43d	26,	12.50	Apr. 16,	10.76
Sept. 2,	16.34c	31,	12.46	May 6,	10.73
7,	15.37d	Nov. 3,	12.44	June 24,	11.63
11,	14.77	9,	12.38	July 12,	12.41
16,	14.24	15,	12.23	Aug. 9,	14.97d
21,	13.88	20,	12.16	Sept. 6,	13.29
24,	13.62	25,	12.09	Oct. 2,	14.30d
Oct. 3,	13.25	30,	12.01	Nov. 1,	15.45d
8,	13.01	Dec. 10,	11.89	Dec. 3,	13.60

c= nearby well being pumped d=nearby well pumped recently

TABLE 2.--Water-level measurements in selected wells
in Burleigh County, North Dakota -- Continued

138-77-15dcb
W. Anderson, irrigation well no. 1

<u>Date</u>	<u>Water level</u>	<u>Date</u>	<u>Water level</u>	<u>Date</u>	<u>Water level</u>
Sept. 21, 1961	12.19b	Aug. 23, 1962	13.72b	Feb. 8, 1963	9.06
Oct. 26,	9.79	Sept. 11,	12.85	Apr. 16,	8.74
Nov. 8,	9.85	12,	12.73	May 6,	8.66
17,	9.66	24,	11.58	June 24,	9.41
Dec. 6,	9.27	Oct. 26,	10.33	Aug. 9,	13.61b
May 1, 1962	8.29	Nov. 16,	10.04	Sept. 6,	11.18
15,	11.88b	Dec. 10,	9.65	Oct. 3,	11.15
June 27,	9.12	Jan. 2, 1963	9.42	Nov. 1,	13.72b
July 28,	8.70	Feb. 7,	9.28	Dec. 3,	11.49
				Jan. 2, 1964	10.62

b= well pumped recently

TABLE 5.--Water-level measurements in selected wells
in Burleigh County, North Dakota -- Continued

138-77-22aad
Test hole 1955

Lowest water level for the day from recorder graph

1961

Day	Jan.	Feb.	Mar.	Apr.	May	June	July	Aug.	Sept.	Oct.	Nov.	Dec.
5										13.19d.	12.40	12.24
10										13.05	12.38	12.15
15										12.87	12.35	12.08
20										12.77	12.34	12.01
25									14.14d.	12.56	12.32	11.94
Eom									13.87d.	12.42	12.29	11.73

1962

Day	Jan.	Feb.	Mar.	Apr.	May	June	July	Aug.	Sept.	Oct.	Nov.	Dec.
5	11.38	10.59	10.38	10.18	15.33d.	12.01	11.01	16.71d.	18.56	13.45	12.64	11.87
10	11.15	10.55e.	10.33e.	10.20	16.39d.	11.74	10.95	16.78d.	16.07	13.26	12.45	11.78
15	10.90e.	10.51	10.30	10.20	16.00d.	11.59	10.91	18.10d.	15.18	13.01	12.32	11.73
20	10.72	10.47	10.26	10.25	13.70	11.40	10.80	19.09d.	14.52	12.87	12.15	11.69
25	10.67h.	10.43h.	10.23	10.40	13.42	11.35	10.80	18.93d.	14.11	12.72	12.14	11.62
Eom	10.62	10.42	10.21h.	10.53h.	12.25	11.21	11.95d.	19.49d.	13.58	12.75	12.00	11.54

1963

Day	Jan.	Feb.	Mar.	Apr.	May	June	July	Aug.	Sept.	Oct.	Nov.	Dec.
5	11.41	11.25	10.97	10.58	10.40	12.65	11.33	17.54d.	13.75	14.15	16.95	13.99
10	11.36	11.24	10.77	10.51	14.02d.	12.04	12.84	17.80d.	13.48	17.04d.	16.34	13.75
15	11.36	11.24	10.72	10.48	13.30d.	11.75	14.68d.	17.95d.	13.52	19.35d.	-----	13.65
20	11.34	11.20	10.70	10.46	11.25	11.72	15.15d.	15.60	13.66	20.05d.	15.71	13.62
25	11.30	11.10	10.66	10.45	14.01d.	11.66	17.61d.	14.81	13.80	19.85d.	-----	13.57
Eom	11.28	11.06	10.61	10.38	15.22d.	11.36	18.20d.	14.16	13.97	17.13	-----	13.56

d=nearyby well pumped recently

e=estimated

h=tape measurment

TABLE 5.--Water-level measurements in selected wells
in Burleigh County, North Dakota -- Continued

138-77-23ddb
R. Baeth, irrigation well no. 1

<u>Date</u>	<u>Water level</u>	<u>Date</u>	<u>Water level</u>	<u>Date</u>	<u>Water level</u>
Sept. 14, 1961	36.70d	May 28, 1962	33.54	Jan. 2, 1963	29.60
21,	32.74	June 20,	30.62	Feb. 7,	29.38
26,	31.41	27,	30.14	Mar. 8,	29.35
Oct. 31,	31.18	July 5,	29.67	Apr. 16,	27.85
Nov. 8,	33.71b	27,	28.71	May 6,	27.75
17,	31.86	Aug. 14,	38.64b	June 24,	31.90
Dec. 6,	30.33	23,	36.28d	Aug. 9,	41.77b
Jan. 25, 1962	28.49	Sept. 11,	38.58b	Sept. 6,	34.22
Mar. 30,	27.58	24,	35.21	Oct. 2,	45.15b
May 1,	33.31	Oct. 26,	32.18	Dec. 3,	36.28
10,	64.89a	Nov. 16,	31.90	Jan. 2, 1964	32.26
15,	40.00b	Dec. 10,	30.56		

a= well being pumped

b= well pumped recently

d= nearby well pumped recently

TABLE 5.--Water-level measurements in selected wells
in Burleigh County, North Dakota -- Continued

138-77-23aac
Test hole 1979

<u>Date</u>	<u>Water level</u>	<u>Date</u>	<u>Water level</u>	<u>Date</u>	<u>Water level</u>
June 19, 1962	26.95	Oct. 5, 1962	30.48	Dec. 5, 1962	28.97
27,	28.17	8,	30.23	10,	28.89
Aug. 14,	31.86	12,	30.11	Jan. 2, 1963	28.28
17,	32.78	16,	30.03	Feb. 7,	27.86
19,	32.86	21,	29.86	Mar. 8,	27.60
23,	33.24	26,	29.64	Apr. 16,	27.30
25,	34.27d	30,	29.85	May 6,	27.33
28,	35.12c	Nov. 2,	29.91	27,	28.20
31,	34.42d	5,	29.60	July 12,	28.18
Sept. 5,	34.10	9,	29.44	Aug. 9,	33.45d
11,	32.72	12,	29.20	Sept. 6,	30.56
16,	31.57	16,	29.15	Oct. 2,	31.72
21,	31.38	20,	29.11	Meas. discontinued	
28,	31.01	25,	29.06		
Oct. 1	30.70	30,	29.02		

c= nearby well being pumped

d= nearby well pumped recently

TABLE 5.--Water-level measurements in selected wells
in Burleigh County, North Dakota -- Continued

138-77-25bbd1
G. D. Adams, irrigation well no. 1

<u>Date</u>	<u>Water level</u>	<u>Date</u>	<u>Water level</u>	<u>Date</u>	<u>Water level</u>
Sept. 7, 1961	39.20b	May 27, 1962	36.30	Feb. 7, 1963	31.27
23,	37.58	June 27,	32.61	Mar. 8,	30.86
Oct. 31,	32.71	July 27,	32.83	Apr. 17,	30.42
Nov. 8,	36.09d	Aug. 16,	45.46d	May 6,	30.32
17,	34.39	23,	38.63	Aug. 9,	44.60d.
Jan. 25, 1962	30.98	Sept. 11,	41.09	Sept. 6,	37.00
Apr. 27,	30.10	24,	37.81	Oct. 2,	65.00a
May 2,	60.67a	Oct. 25,	34.72	21,	66.50a
4,	68.33a	Nov. 16,	34.54	Nov. 1,	47.25b
10,	69.61a	Dec. 10,	33.15	Dec. 3,	37.00
15,	42.59b	Jan. 2, 1963	32.14	Jan. 2, 1964	35.93

a= well being pumped b= well pumped recently d= nearby well pumped recently

TABLE 5.--Water-level measurements in selected wells
in Burleigh County, North Dakota -- Continued

138-77-26adc
Test hole 1954

<u>Date</u>	<u>Water level</u>	<u>Date</u>	<u>Water level</u>	<u>Date</u>	<u>Water level</u>
Sept. 22, 1961	34.87d	Mar. 26, 1962	27.80	Jan. 2, 1963	39.77
Oct. 31,	31.94	Apr. 1,	27.60	Feb. 7,	28.63
Nov. 8,	34.39d	May 1,	31.74	Mar. 8,	28.30
17,	32.83	9,	40.17d	Apr. 17,	27.80
Dec. 4,	30.80	15,	38.99	May 6,	27.33
Jan. 5, 1962	29.51	June 27,	30.48	June 26,	32.15
Feb. 5,	29.20	Aug. 16,	37.60d	Aug. 9,	40.15d
12,	28.80	23,	36.38d	Sept. 6,	34.99
19,	28.20	Sept. 24,	36.69d	Oct. 2,	40.70d
Mar. 12,	28.00	Oct. 26,	33.10	21,	43.22d
19,	27.90	Dec. 10,	31.18	Nov. 1,	42.61d

d= nearby well pumped recently.

138-78-27ccd
Test hole 2042

<u>Date</u>	<u>Water level</u>	<u>Date</u>	<u>Water level</u>	<u>Date</u>	<u>Water level</u>
Aug. 16, 1962	42.35	Jan. 3, 1963	42.49	Aug. 9, 1963	42.14
31,	42.42	Feb. 7,	42.55	Sept. 6,	42.76
Sept. 11,	42.48	Mar. 8,	42.49	Oct. 2,	42.92
Oct. 3,	42.54	Apr. 16,	42.37	Nov. 1,	42.83
26,	42.53	May 7,	42.35	Dec. 3,	43.07
Dec. 10,	42.50	June 24,	42.35	Jan. 2, 1964	42.92

TABLE 5.--Water-level measurements in selected wells
in Burleigh County, North Dakota -- Continued

138-78-32daa
Test hole 2012

<u>Date</u>	<u>Water level</u>	<u>Date</u>	<u>Water level</u>	<u>Date</u>	<u>Water level</u>
Aug. 16, 1962	48.46	Jan. 3, 1963	48.44	Aug. 9, 1963	48.41
31,	48.22	Feb. 7,	48.47	Sept. 6,	48.68
Sept. 11,	48.26	Mar. 8,	48.34	Oct. 2,	48.79
Oct. 3,	48.44	Apr. 16,	48.18	Nov. 1,	48.80
26,	48.48	May 7,	48.18	Dec. 3,	48.85
Dec. 10,	48.47	June 24,	48.21	Jan. 2, 1964	48.74

138-80-2ccc
Test hole 2057

<u>Date</u>	<u>Water level</u>	<u>Date</u>	<u>Water level</u>	<u>Date</u>	<u>Water level</u>
Sept. 11, 1962	21.13	Jan. 2, 1963	21.17	June 24, 1963	20.74
25,	21.45	Feb. 7,	21.11	Aug. 9,	21.15
Oct. 25,	21.35	Mar. 7,	21.02	Sept. 6,	21.37
Nov. 16,	21.20	Apr. 16,	20.88	Oct. 2,	21.45
Dec. 7,	21.19	May 6,	20.86	Nov. 1,	21.57
				Jan. 2, 1964	21.24

TABLE 5.--Water level measurements in selected wells
in Burleigh County, North Dakota -- Continued

138-80-9bcc
P. Wachter, irrigation well no. 1

<u>Date</u>	<u>Water level</u>	<u>Date</u>	<u>Water level</u>	<u>Date</u>	<u>Water level</u>
Sept. 8, 1961	19.70	Nov. 26, 1962	18.74	June 24, 1963	16.51
June 27, 1962	15.35	Dec. 7,	18.57	July 8,	16.34
27,	49.50a	Jan. 2, 1963	18.05	Aug. 9,	16.89
Aug. 23,	17.39	Feb. 7,	17.51	Sept. 6,	17.89
Sept. 11,	17.48	Mar. 7,	16.12	Nov. 1,	55.00a
Nov. 5,	23.66b	Apr. 16,	15.93	Dec. 3,	18.78
8,	20.57b	May 7,	15.85	Jan. 2, 1964	16.97

a= well being pumped

b= well pumped recently

TABLE 5.--Water-level measurements in selected wells
in Burleigh County, North Dakota -- Continued

138-80-15cdd
Test hole 1956

Lowest water level for the day from recorder graph

1961

Day	Jan.	Feb.	Mar.	Apr.	May	June	July	Aug.	Sept.	Oct.	Nov.	Dec.
5										35.45	39.88	38.85
10										39.78h.	39.43h.	38.75
15										40.15	39.29	38.64
20										40.85d.	39.14	38.53
25										40.70d.	39.04	38.45
Eom										40.49d.	38.94	38.33

1962

Day	Jan.	Feb.	Mar.	Apr.	May	June	July	Aug.	Sept.	Oct.	Nov.	Dec.
5	38.31			36.45	37.34d.	36.55	36.83	39.00d.	38.77	39.18d.	38.80	38.74
10	38.09		36.90e.	36.50	38.20d.	36.50	37.05	38.97d.	38.76	3.89	38.70	38.73
15	37.98			36.55	37.29	36.43	37.13	38.56h.	38.85	39.43	38.68	38.73e.
20	37.85	37.21e.		36.61	36.87	36.48	37.19	38.58d.	39.07d.	39.51	38.71	38.72
25	37.70			36.66	36.71h.	36.72	38.27d.	38.62	39.25d.	39.42	38.69	3.71e.
Eom	37.59e.		36.57	36.77	36.64	37.00	38.95d.	38.75h.	39.15.	39.30	38.70	38.70

1963

Day	Jan	Feb.	Mar.	Apr.	May	June	July	Aug.	Sept.	Oct.	Nov.	Dec.
5	38.60	37.59	37.16	36.80	37.11	37.51	37.70	39.46	38.93	40.62d.	41.60d.	39.60
10	38.43	37.50	36.89	36.94	37.19	37.49	38.69	39.15	39.12	40.14	40.26	39.40
15	38.31	37.48	36.84	36.89	37.26	37.63	39.18d.	39.16	39.31	40.50d.	40.05	-----
20	38.08	37.27	36.80	36.98	37.33	38.78d.	39.25	39.12	39.53	39.86	39.74	-----
25	37.98	37.28	36.75	36.98	37.61	37.77	39.31	38.98	39.38	40.31d.	39.65	-----
Eom	37.80	37.27	36.83	36.97	37.58	37.60	39.57	38.96	39.94	40.37d.	39.62	38.15

d=nearby well pumped recently

e=estimated

h=tape measurement

TABLE 5.--Water-level measurements in selected wells
in Burleigh County, North Dakota -- Continued

138-80-17acb

J. Peterson, irrigation well no. 1

<u>Date</u>	<u>Water level</u>	<u>Date</u>	<u>Water level</u>	<u>Date</u>	<u>Water level</u>
Sept. 8, 1961	14.42	Nov. 6, 1962	17.98	May 7, 1963	15.36
May 1, 1962	14.85	14,	31.82a	June 5,	15.39
June 27,	14.90	19,	18.00	July 8,	15.85
July 27,	15.79	Dec. 7,	17.94	Aug. 9,	16.69b
Aug. 23,	16.96d	Jan. 2, 1963	17.26	Sept. 6,	17.14b
Sept. 11,	17.19d	Feb. 7,	16.57	Oct. 2,	17.77d
Oct. 25,	17.95d	Mar. 7,	15.22	Nov. 1,	18.39d
Nov. 5,	18.06d	Apr. 16,	15.32	Dec. 2,	17.93

a= well being pumped b= well pumped recently d= nearby well being pumped

138-80-22aac

D. McDonald, irrigation well no. 1

<u>Date</u>	<u>Water level</u>	<u>Date</u>	<u>Water level</u>	<u>Date</u>	<u>Water level</u>
Sept. 23, 1961	43.27	Aug. 24, 1962	43.00	Mar. 12, 1963	41.17
Oct. 10,	43.07	Sept. 11,	43.08	Apr. 16,	41.32
19,	44.14b	Oct. 25,	44.66c	Aug. 9,	43.43c
May 1, 1962	41.08	Dec. 7,	43.57	Sept. 6,	43.23c
June 27,	41.02	Jan. 2, 1963	42.92	Oct. 8,	43.55c
July 27,	43.16c	Feb. 7,	41.77	Nov. 1,	55.72b

b= well pumped recently c= nearby well pumped recently

TABLE 5.--Water-level measurements in selected wells
in Burleigh County, North Dakota -- Continued

138-80-23bdc

D. Solberg, irrigation well no. 1

<u>Date</u>	<u>Water level</u>	<u>Date</u>	<u>Water level</u>	<u>Date</u>	<u>Water level</u>
Sept. 7, 1961	35.93	Sept. 11, 1962	35.78	May 17, 1963	34.16
Oct. 10,	35.22	Oct. 25,	36.40b	June 24,	34.93
14,	36.98d	Dec. 7,	35.73	Aug. 9,	78.18a
19,	35.37	Jan 2, 1963	35.60	Sept. 6,	35.97
May 1, 1962	33.45	Feb. 7,	34.50	Oct. 2,	80.14a
June 27,	32.98	Mar. 7,	33.68	Nov. 1,	38.36b
Aug. 23,	35.94b	Apr. 16,	34.07		

a= well being pumped

b= well pumped recently

d= nearby well pumped recently

138-80-24cac

Yegen Dairy, irrigation well no. 1

<u>Date</u>	<u>Water level</u>	<u>Date</u>	<u>Water level</u>	<u>Date</u>	<u>Water level</u>
Sept. 9, 1961	12.00b	Jan. 2, 1963	9.54	May 8, 1963	8.99
Oct. 12,	7.40	Feb. 7,	9.09	June 24,	11.82b
May 1, 1962	6.54	Mar. 7,	8.74	Aug. 8	10.43
Aug. 24,	28.79a	Apr. 5,	8.48	Sept. 6,	9.10
Oct. 25,	6.85	18,	8.69		
Dec. 7,	10.01	May 6,	6.94		

a= well being pumped

b= well pumped recently

TABLE 5.--Water-level measurements in selected wells
in Burleigh County, North Dakota -- Continued

138-80-25bab
Yegen Dairy, irrigation well no. 2

<u>Date</u>	<u>Water level</u>	<u>Date</u>	<u>Water level</u>	<u>Date</u>	<u>Water level</u>
May 6, 1963	8.99	Aug. 8, 1963	12.99 ^b	Oct. 2, 1963	10.84
June 24,	12.63 ^b	Sept. 6,	11.19	Nov. 1,	37.70 ^a

a= well being pumped

b= well pumped recently

139-75-19caa
Test hole 2049-D

<u>Date</u>	<u>Water level</u>	<u>Date</u>	<u>Water level</u>	<u>Date</u>	<u>Water level</u>
Mar. 28, 1963	10.79	May 7, 1963	10.75	Sept. 6, 1963	9.96
Apr. 5,	10.82	Aug. 9,	10.69	Oct. 2,	10.10

139-78-27cbb
Test hole 2037

<u>Date</u>	<u>Water level</u>	<u>Date</u>	<u>Water level</u>	<u>Date</u>	<u>Water level</u>
Aug. 17, 1962	24.34	Jan. 2, 1963	24.30	Aug. 9, 1963	23.92
30,	24.22	Feb. 7,	24.28	Sept. 6,	24.13
Sept. 11,	24.27	Mar. 8,	24.30	Oct. 2,	24.12
Oct. 3,	24.29	Apr. 17,	23.97	Nov. 1,	24.24
26,	24.34	May 6,	24.23	Jan. 2, 1964	24.18
Dec. 10,	24.35	June 25,	23.75		

TABLE 5.--Water-level measurements in selected wells
in Burleigh County, North Dakota -- Continued

139-81-11bdd
R. Ward, irrigation well no. 1

<u>Date</u>	<u>Water level</u>	<u>Date</u>	<u>Water level</u>	<u>Date</u>	<u>Water level</u>
May 1, 1961	15.45b	Mar. 12, 1963	14.02	Sept. 17, 1963	14.70
Sept. 8,	15.00	Apr. 16,	12.98	Oct. 2,	14.55
Dec. 10, 1962	15.04	May 7,	12.94	Nov. 1,	32.28a
Jan. 2, 1963	14.99	June 24,	13.70		

a= well being pumped

b= well pumped recently

140-75-1aaa
Test hole 2049-A

<u>Date</u>	<u>Water level</u>	<u>Date</u>	<u>Water level</u>	<u>Date</u>	<u>Water level</u>
Mar. 28, 1963	51.65	June 25, 1963	52.30	Oct. 2, 1963	52.27
Apr. 5,	52.24	Aug. 9,	52.52	Nov. 1,	52.62
May 7,	51.96	Sept. 6,	52.34	Jan. 2, 1964	51.87

140-75-12cdd
Test hole 2049

<u>Date</u>	<u>Water level</u>	<u>Date</u>	<u>Water level</u>	<u>Date</u>	<u>Water level</u>
Aug. 17, 1962	13.26	Jan. 3, 1963	13.33	June 25, 1963	13.46
29,	13.26	Feb. 7,	13.37	Aug. 9,	13.65
Sept. 24,	13.35	Mar. 8,	13.44	Sept. 6,	13.63
Oct. 4,	13.26	28,	13.35	Oct. 2,	13.72
26,	13.28	Apr. 5,	13.47	Nov. 1,	13.76
Dec. 10,	13.37	May 7,	13.52	Jan. 2, 1964	13.65

TABLE 5.--Water-level measurements in selected wells
in Burleigh County, North Dakota -- Continued

140-75-24ddd
Test hole 2049-B

<u>Date</u>	<u>Water level</u>	<u>Date</u>	<u>Water level</u>	<u>Date</u>	<u>Water level</u>
Mar. 28, 1963	4.61	June 25, 1963	4.66	Oct. 2, 1963	4.87
Apr. 5,	4.67	Aug. 9,	4.75	Nov. 1,	4.81
May 7,	4.76	Sept. 6,	4.77	Jan. 2, 1964	4.77

140-76-33bbb
Test hole 2018

<u>Date</u>	<u>Water level</u>	<u>Date</u>	<u>Water level</u>	<u>Date</u>	<u>Water level</u>
Aug. 15, 1962	1.8 gpm	Jan. 2, 1963	1.4 gpm	Aug. 9, 1963	1.2 gpm
29,	1.1 gpm	Feb. 7,	1.4 gpm	Sept. 6,	1.3 gpm
Sept. 24,	1.2 gpm	Mar. 8,	Frozen	Oct. 2,	1.1 gpm
Oct. 26,	1.3 gpm	Apr. 16,	1.2 gpm	Nov. 1,	1.2 gpm
Dec. 10,	1.5 gpm	June 24,	1.0 gpm	Jan. 2, 1964	0.2 gpm

gpm= gallons per minute flow.

140-78-36bba
Test hole 2009

<u>Date</u>	<u>Water level</u>	<u>Date</u>	<u>Water level</u>	<u>Date</u>	<u>Water level</u>
Aug. 17, 1962	12.81	Jan. 2, 1963	12.99	Aug. 9, 1963	12.80
30,	12.88	Feb. 7,	12.95	Sept. 6,	12.90
Sept. 11,	12.90	Mar. 8,	12.90	Oct. 2,	12.97
Oct. 3,	12.98	Apr. 17,	12.88	Nov. 1,	12.95
26,	13.02	May 6,	12.94		
Dec. 10,	13.04	June 25,	12.52		

TABLE 5.--Water-level measurements in selected wells
in Burleigh County, North Dakota -- Continued

140-81-5aaa
Test hole 1983

<u>Date</u>	<u>Water level</u>	<u>Date</u>	<u>Water level</u>	<u>Date</u>	<u>Water level</u>
June 21, 1962	7.84	Oct. 26, 1962	8.36	May 7, 1963	7.05
July 20,	7.49	Dec. 7,	9.37	June 24,	6.35
Aug. 15,	7.39	Jan. 2, 1963	8.34	Aug. 9,	7.35
30	7.77	Feb. 6,	7.23	Sept. 6,	8.07
Sept. 12,	7.58	Mar. 7,	6.55	Oct. 3,	8.54
25,	8.67	Apr. 17,	6.89	Nov. 1	7.76
				Jan. 2, 1964	6.74

141-80-35cc
C. DeLong

<u>Date</u>	<u>Water level</u>	<u>Date</u>	<u>Water level</u>	<u>Date</u>	<u>Water level</u>
Nov. 21, 1940	15.90	Sept. 10, 1949	15.58	Sept. 16, 1954	13.79
Apr. 4,	15.33	Nov. 25,	14.82	Apr. 21, 1955	13.60
Nov. 20,	15.65	25, 1950	13.22	Oct. 25, 1955	14.50
Aug. 12, 1942	15.61	June 25, 1951	14.04	May 4, 1956	13.28
May 23, 1943	14.47	Nov. 10,	13.85	Nov. 14,	17.14
8, 1944	14.47	Apr. 25, 1952	13.33	May 2, 1957	13.77
Sept. 3,	14.86	Aug. 3,	14.95	Sept. 4, 1958	15.75
May 12, 1945	14.29	9,	15.00	No. meas. 1959	
18, 1946	14.34	Sept. 24,	15.04	Meas. discontinued	
Oct. 2,	15.17	May 5, 1953	13.42		
No meas. 1947		Nov. 19,	14.32		
Sept. 13, 1948	15.85	Apr. 30, 1954	13.77		

TABLE 5.--Water-level measurement in selected wells
in Burleigh County, North Dakota -- Continued

142-75-19ccb
Test hole 1995

<u>Date</u>	<u>Water level</u>	<u>Date</u>	<u>Water level</u>	<u>Date</u>	<u>Water level</u>
Aug. 14, 1962	5.75	Jan. 3, 1963	5.91	June 25, 1963	5.96
29,	5.59	Feb. 7,	5.95	Aug. 9,	6.25
Sept. 20,	5.81	Mar. 8,	6.03	Sept. 6,	6.32
Oct. 26,	5.66	28,	5.96	Oct. 2,	6.39
Dec. 10	5.92	May 7,	5.94	Nov. 1,	6.38

REFERENCES

- Goldman, M. I. and Merwin, H. E., 1928, Color chart for field description of sedimentary rocks: National Research Council.
- Greenman, D. W., 1953, Reconnaissance of the Missouri River pumping units between Garrison Dam and Bismarck, North Dakota: U. S. Geol. Survey open file report, 65p.
- Robinove, C. V., Langford, R. H., and Brookhart, J. W., 1958, Saline-water resources of North Dakota: U. S. Geol. Survey Water Supply Paper, 1428, p.16-17.
- Simpson, H. E., 1929, Geology and ground-water resources of North Dakota: U. S. Geol. Survey, 598, p.281.
- Wentworth, C. K., 1922, A scale of grade and class terms for clastic sediments: Jour. of Geol., vol. 30, p. 377-392.